

Technical Specifications

 **multipower**

MP2 300 – 500 – 600 kW MODULAR THREE-PHASE IN/OUT
ON LINE Double Conversion Technology (VFI)



CONTENTS

1. OBJECTIVE	2
2. REFERENCE STANDARDS	2
3. APPLICATIONS	3
4. SYSTEM MAIN FEATURES	4
5. INNOVATIVE TECHNOLOGY	5
5.1 SiC – Silicon Carbide	5
5.2 Interleaving	5
6. SYSTEM CONFIGURATIONS	6
6.1 Power cabinet	6
6.2 System Description	7
6.3 MP2 300 PCM Overview	8
6.4 MP2 500 PCM Overview	9
6.5 MP2 600 Frames Overview	10
6.6 Operating Configuration	11
7. MULTI POWER PARTS DESCRIPTION	13
7.1 Power Module (PM)	17
7.1.1 Overall Module Control	18
7.1.2 Embedded Intelligence and Firmware Alignment	18
7.1.3 PFC Input Converter	18
7.1.4 Inverter	19
7.1.5 Battery Charger (Battery Care System)	21
7.2 Bypass Module	23
8. DISPLAY AND STATUS LED	26
8.1 Display	27
8.1.1 Display Icons, Symbols and Texts	28
8.1.2 Active Text Areas	29
8.1.3 UPSs List	29
8.1.4 Menu	30
8.2 Status Led	31
9. CONNECTIVITY PANEL	32
9.1 Connectivity Panel for MP2 300	32
9.1.1 R.E.P.O.	33
9.1.2 Programmable In – Out Signals	33
9.1.3 Auxiliary Signals	34
9.1.4 Communication Slots	34
9.2 Connectivity Panel for MP2 500 and MP2 600	35
9.2.1 System Monitoring Unit	36
9.2.2 R.E.P.O.	36
9.2.3 Programmable In – Out Signals	36
9.2.4 Auxiliary Signals	37
9.2.5 Communication Slots	38
9.2.6 Air Pressure Sensor	38
9.3 Communication Cards	38
9.4 Display Port	39
9.5 USB (service port)	39
9.6 Parallel Card	39
10. STANDARD FEATURES	40
10.1 Front Door Air Filter	40
10.2 Redundant Communication Buses	40
10.3 External Synchronisation	40
10.4 Fire Detection Cable MP2 500 and MP2 600	41
10.5 Monitoring and Control Software	41
10.6 Top ventilation	42
11. SPECIFIC OPTIONS AND ACCESSORIES MP2 300 PCM	43

11.1	<i>Parallel MP2 300</i>	43
11.2	<i>Front Door Air Filter MP2 300 PCM</i>	44
11.3	<i>Bottom Cable Entry MP2 300 PCM</i>	44
11.4	<i>I/O Side cabinet MP2 300 PCM</i>	45
11.5	<i>Top Ventilation Kit MP2 300 PCM</i>	45
12.	SPECIFIC OPTIONS AND ACCESSORIES MP2 500 / MP2 600	46
12.1	<i>Parallel MP2 500 and MP2 600</i>	46
12.2	<i>Optical fiber bus kit</i>	46
12.3	<i>Bottom Cable Entry for MP2 500 and MP2 600</i>	47
12.4	<i>TN-C kit for MP2 500 PCM</i>	47
12.5	<i>Seismic kit MP2 500 PCM</i>	47
13.	COMMON OPTIONS AND ACCESSORIES MP2 FAMILY	48
13.1	<i>Battery Cabinet Description</i>	48
13.1.1	<i>Conventional Battery Cabinets</i>	49
13.2	<i>External Battery Temperature Sensor</i>	50
13.3	<i>Separate Input lines (DI)</i>	50
13.4	<i>Optional Transformers</i>	51
13.4.1	<i>Separated lines upstream (DI)</i>	52
13.5	<i>Communication cards</i>	52
13.6	<i>EnergyManager for Li-Ion batteries</i>	53
13.7	<i>Cold Start</i>	53
14.	ENVIRONMENTAL DATA MP2	54
15.	TECHNICAL DATA	54
16.	ELECTRICAL DATA	56
17.	SUMMARY TABLE	60

1. OBJECTIVE

These specifications define the technical characteristics of the **Multi Power2 – MP2** uninterruptible power supply (UPS). The UPS is designed to provide a clean and stable electrical supply, irrespective of the condition of the mains or an alternative power supply.

The **Multi Power2** series of UPS is designed and manufactured by Riello UPS, a leader in this field with a range of products from 350 VA to 1600 kVA and over 30 years of experience in power protection.

For more information, please visit our website at: www.riello-ups.com

2. REFERENCE STANDARDS

Riello UPS operates a Quality Management System certified to ISO 9001/2015 (Certification No. CERT-04674-99-AQ-VEN-SINCERT) covering all company functions from design and manufacture to after sales services.

This certification is a guarantee for the customer with regard to the following aspects:

- use of quality materials;
- meticulousness in the production and testing phases;
- continued customer support.

In addition, the UPS meets the stringent standards according to IEC EN 62040-3 (VFI-SS-111) and complies with the following specific standards for UPS:

- **IEC EN 62040-1:** Static uninterruptible power supplies (UPS): general and safety provisions;
- **IEC EN 62040-2:** Electromagnetic compatibility (EMC) requirements category C3;
- **IEC EN 62040-3:** Methods of specification of performances and test provisions;

The **Multi Power2** series also satisfies the following general standards, where applicable:

- **IEC 60529:** Degree of protection provided by enclosures;
- **IEC 60664:** Insulation for low-voltage equipment;
- **IEC 60755:** General Requirements for Residual Current Operated Protective Devices;
- **IEC 62477-1:** Safety requirements for power electronic converter systems and equipment
- **IEC 61000-4-2:** Electrostatic discharge immunity test;
- **IEC 61000-4-3:** Radio frequencies, electromagnetic immunity test;
- **IEC 61000-4-4:** Transitory overvoltage immunity test;
- **IEC 61000-4-5:** Overvoltage immunity test;
- **IEC 61000-4-6** Immunity to conducted disturbances, induced by radio-frequency fields
- **IEC 61000-4-8** Power frequency magnetic field immunity test

European Directives:

LVD directive 2014/35/EU

The LVD covers all health and safety risks of electrical equipment operating with a voltage between 50 and 1000 V for alternating current and between 75 and 1500 V for direct current.

EMC directive 2014/30/EU

The EMC Directive limits electromagnetic emissions from equipment; the Directive also governs the immunity of such equipment to interferences.

3. APPLICATIONS

Multi Power2 UPS is the ultimate modular UPS, suitable for applications requiring critical load protection such as:

Medium and large Data Centres: The unity output power factor ensures greater active power availability for efficient UPS loading.

The compact and modular design allows scalability to suit business growth in a very small footprint, while the very high values of efficiency provide low operational costs and a more sustainable solution.

e-business and Telecommunications: Parallel modular operation means that the installed UPS size can be increased (up to 2.4 MW) to keep pace with the growth of the organization, maintaining the highest levels of power protection, availability and investment savings.

Critical load application: The UPS is designed to protect a range of critical loads within other specific sectors such as healthcare, retail, education, and transport, where power outages are not tolerated or result in loss of revenue for a system failure. This has been achieved through careful frame solutions based on modularity and scalability principles which ensure the following features:

- UPS modularity
- Built-in redundancy
- High short circuit and overload capability
- Overall operation flexibility and comprehensive monitoring

All in all, Multi Power2 stands out for its unique and outstanding efficiency up to 98.1% in ONLINE mode, that make it the best solution for powering the most demanding loads, not only in terms of business continuity but also in terms of sustainability.

4. SYSTEM MAIN FEATURES

The Multi Power2 is an online double conversion technology UPS, scalable up to 600 kW (in a single unit). According to the demands of the business, systems can be parallelized to increase the rated power up to 2.4 MW. Thanks to its innovative technology, the UPS can reach outstanding efficiency while working in online double conversion, providing a sustainable and cost oriented solution. The product has been designed to protect the load even during system extension or maintenance operations.

Multi Power2 key features:

- Sustainable and with brilliant performances:
 - Efficiency up to **98.1%** in ONLINE mode (BLUE module)
 - Very low operational expenses
 - Full power up to 40°C

- Increased power density:
 - Very compact design
 - 600 kW in just 0.52 m²
 - 1.75 kW / dm³ for the power module

- Safe, reliable and flexible:
 - **Modular design**, with totally independent and **hot swap** power modules
 - Quick and safe upgrade of the system (no human mistakes)
 - Adaptable to installation requirements

- User friendly interface:
 - 10" touchscreen colour display
 - Easy access to all system information

- Smart features
 - Constant monitoring (temperature and fan status)
 - Easy and secure remote connection
 - Riello Connect ready



5. INNOVATIVE TECHNOLOGY

5.1 SiC – SILICON CARBIDE

Multi Power2 is paving the way for new benchmarks in UPS efficiency, capable of reaching an efficiency up to 98.2% @ 400V working in double conversion. With our best-in-class power module MP2 67 PM BLUE, based on latest silicon carbide technology, the Multi Power2 minimizes the overall operational expenses and the cooling requirements.

Lower losses mean not only higher efficiency, but also less stress for the other electronic components within the power module, providing a more compact, reliable and robust solution.

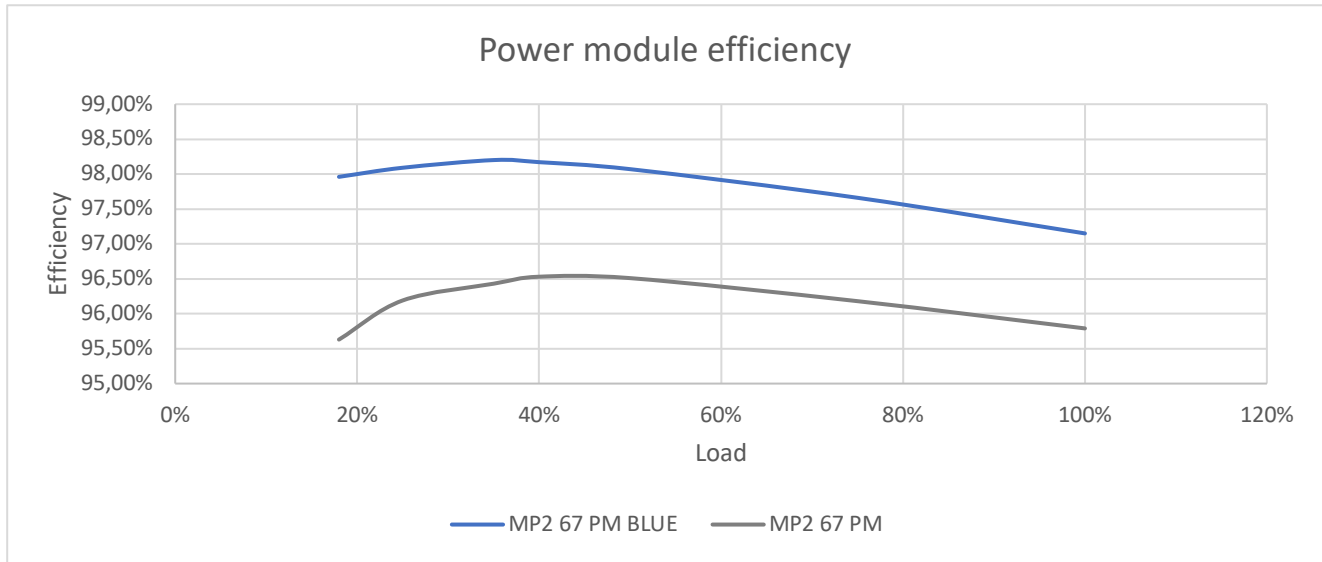

5.2 INTERLEAVING

In most electronic devices, the DC current signal applied to a circuit has an AC portion (referred as the ripple current). The ripple current raises the internal temperature of the capacitors reducing their lifespan and increasing their failure rate, impacting the overall reliability of electronic devices.

To minimize the ripple current, Multi Power2 manages the converters by properly synchronizing the PWM signals used to drive each converter stage while the unit is working in battery mode. This behaviour enhances the lifespan of both batteries and DC capacitors.

6. SYSTEM CONFIGURATIONS

Several cabinet frames are available to provide the best solution according to the project specifications. The UPS Power Modules are ‘hot swappable’, allowing non-intrusive scaling up or down, and replacement (if it is required), without the need to power down and interrupt the critical IT load.

6.1 POWER CABINET

The Power Cabinet is one of the key elements of the Multi Power2 modular solution granting continuous and high-quality power supply. All the relevant building blocks which make up the cabinet are swappable to ensure easy, safe, non-intrusive and quick maintenance operations.

Power Cabinets can accommodate either the standard 67 kW Power Modules (MP2 67 PM), or the BLUE version (MP2 67 PM BLUE) according to the level of efficiency needed for the specific project and the configuration selected.

Each unit is provided with air filters to ensure the highest level of flexibility and the best working condition for the UPS (optional for MP2 300 PCM).

Up to four complete Power Cabinets can be connected in parallel.

The internal communication architecture and the parallel logic are based on two fully redundant buses which ensures continuous and secure UPS operations if one communication link fails (or even if there is a short circuit in one of the two buses). If this condition does occur, a warning is immediately raised to the user, so that all corrective actions can be taken in order to restore the full communication link.

The available UPS power and redundancy level can expand vertically using the MP2 67 PM or MP2 67 PM BLUE:

- 67 to 300 kW in one single Power Cabinet (MP2 300 PCM) and up to 1200 kW with four cabinets in parallel.
- 67 to 500 kW in one single Power Cabinet (MP2 500 PCM) and up to 2000 kW with four cabinets in parallel.
- 67 to 600 kW in one single Power Cabinet (MP2 600 PC0, MP2 600 PC0 VE, MP2 600 PCS VE) and up to 2400 kW with four cabinets in parallel.

Cabinets can be provided with only manual bypass (PCM), without any switch (PC0) and with all the switches (PCS). The “VE” versions, available for MP2 600 PC0 VE and MP2 600 PCS VE units, are also equipped with TOP ventilation in standard (all units with top ventilation work only with BLUE modules).

To see the compatibility of the configuration with each model, please refer to the information reported further in this chapter.

For the nature of this design as a modular UPS, Multi Power2 should not be sized to work with the n modules at full capacity, but at design stage with at least one PM running as redundant unit for each power cabinet.

Battery backup time can expand according with the higher demand of business.

Multi Power2 units are fully compatible with the Multi Power battery cabinet, so the user may decide to build up the backup time with Riello UPS solution or selecting conventional battery block batteries housed in a free-standing framework following the 40 blocks, 2 wires architecture (without neutral point).

For further details on the cabinet configurations check the Summary Table in chapter 17 at the end of the document.

6.2 SYSTEM DESCRIPTION

The models described above are realized using the same major building blocks in all frames.

The major parts listed below are designed to provide quick and safe operation during replacement or upgrading, therefore granting business continuity. In the exceptional event of “bypass module” replacement a manual bypass operation is mandatory to ensure a safe operation for the site engineer.

ITEM	ACRONYM	DESCRIPTION
Power Module	PM	Acronym used to indicate M2P2 67 PM or MP2 67 PM BLUE
Power Module 67 IGBT	MP2 67 PM	67 kW Power Module unit, 3U, IGBT architecture
Power Module 67 BLUE	MP2 67 PM BLUE	67 kW Power Module unit, 3U, high efficiency, full SiC topology
Bypass Module	BM	Acronym used to indicate the bypass module
Bypass Module MP2 300	MP2 500 Amp BM	300 kW Transfer device module without backfeed contactor
Bypass Module MP2 500	MP2 500 BM	500 kW Transfer device module without backfeed contactor
Bypass Module MP2 600	MP2 600 BM	600 kW Transfer device module without backfeed contactor
Connectivity Panel	CP	User and service system interface panel, with embedded I/O signals and network card
System Monitoring Unit	SMU	Monitoring device
Main communication Unit	MCU	Display of the unit
Parallel Interface board	PIB	Parallel interface board
Power column cabinet	PCC	Section of the UPS hosting the power modules

6.3 MP2 300 PCM OVERVIEW

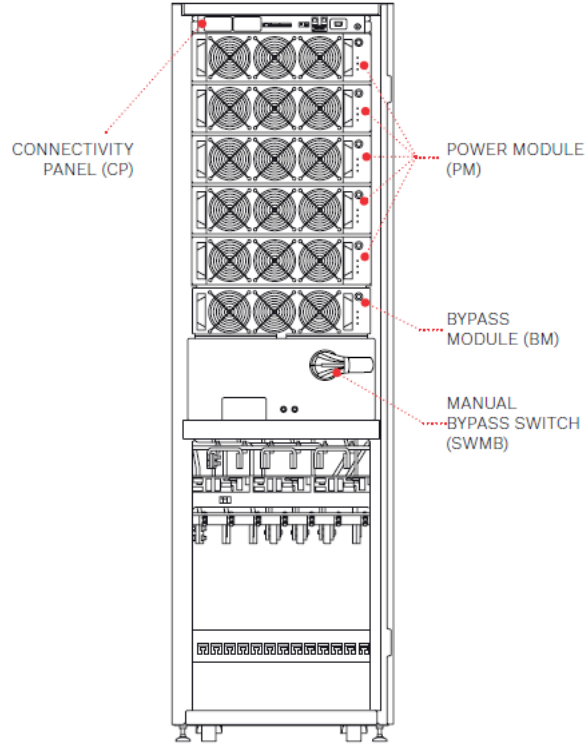

*MP2 300 PCM
(300 kW frame with manual bypass)*

	PMs TO REACH MAX POWER OF THE CABINET	POWER SLOTS AVAILABLE
MP2 300 PCM	5	5

6.4 MP2 500 PCM OVERVIEW

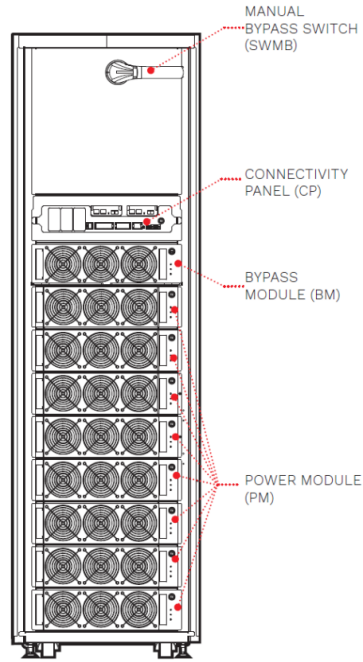

*MP2 500 PCM
(500 kW frame with manual bypass)*

	PMs TO REACH MAX POWER OF THE CABINET	POWER SLOTS AVAILABLE
MP2 500 PCM	8	8

6.5 MP2 600 FRAMES OVERVIEW

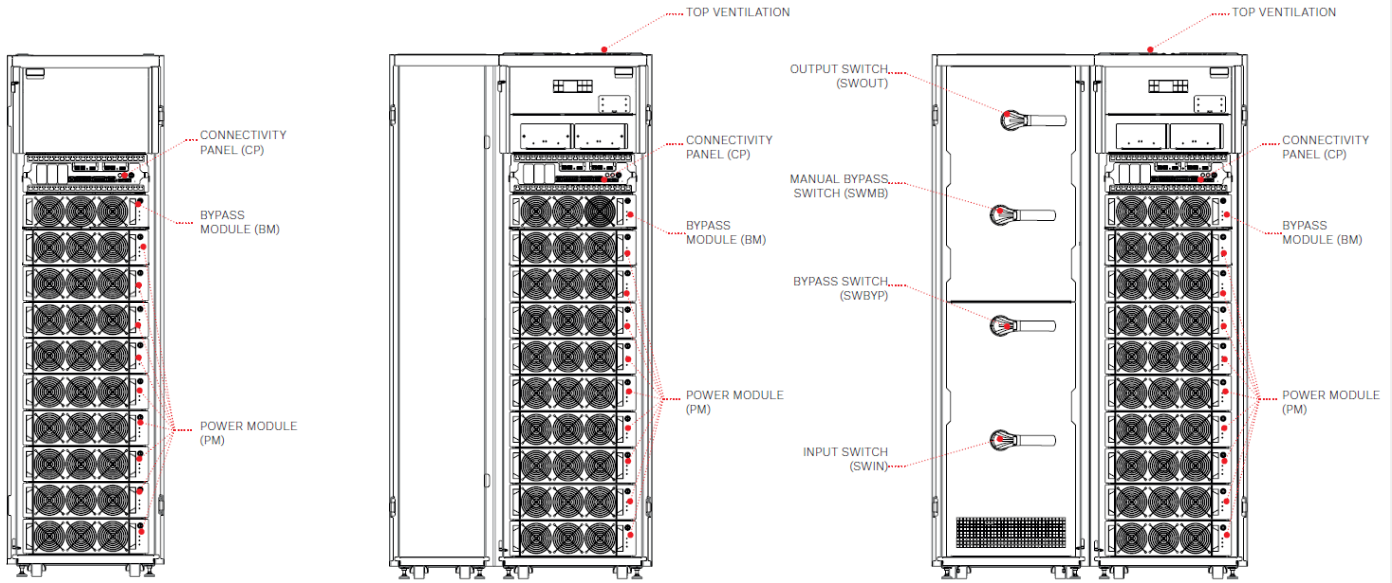

*MP2 600 PC0
(600 kW frame
without switches)*

*MP2 600 PC0 VE
(600 kW frame without switches +
TOP ventilation)*

*MP2 600 PCS VE
(600 kW frame with input, bypass, output and
manual bypass switches + TOP ventilation)*

	PMs TO REACH MAX POWER OF THE CABINET	POWER SLOTS AVAILABLE
MP2 600 PC0, PC0 VE and PCS VE	9	9

6.6 OPERATING CONFIGURATION

Multi Power2 architecture can operate in the following different main operating modes: ON LINE, FREQUENCY CONVERTER, ECO, SMART ACTIVE, EFFICIENCY CONTROL and in their main variants described in following paragraph.

Working in ON LINE MODE Multi Power2 grants an overall efficiency up to 96.5% (PM 67) or 98.2% (PM 67 BLUE) at module level.

Mode: ON LINE

Normal Operation: The rectifier, drawing power from the mains power supply, supplies the Inverter and charges the batteries; the load is powered by the Inverter which provides a clean and secure supply, synchronised to the bypass supply.

Emergency Operation: if the mains power supply wanders outside the permitted input range (voltage and frequency), the rectifier shuts down and the Inverter is automatically powered by the battery for the preset backup time, without any disruption to the load. When the mains power supply returns, the rectifier gradually starts, charging the batteries and eventually powers the Inverter.

Operation from By-pass: if an Inverter overload exceeds permitted limits (or it stops due to a fault), the load automatically transfers to the emergency bypass supply via the static switch, without disruption to the load.

Mode: FREQUENCY CONVERTER

The UPS can be configured as a frequency converter (with "Service SW"), therefore when the input frequency is 50 Hz the output frequency can be 60 Hz and vice versa. During this mode of operation, the automatic bypass is disabled. The UPS can work in frequency converter mode with or without the batteries (must be set up with "Service SW").

Please refer to your pre-sales contact for further details about the design life in this specific operating mode.

Mode: ECO

In order to optimise the overall efficiency of the UPS, in ECO mode, the load is normally powered via bypass (any disturbances that occur in the network can have effects on the load). In the event of a mains power supply failure or if the power supply is not within the pre-set tolerances, the UPS will switch to normal ON LINE operation with double conversion. Approximately five minutes after the power supply returns within tolerance, the load is switched back to bypass.

ECO activation as well as sensitivity adjustment is granted to authorized personnel only (via "Service SW").

Mode: SMART ACTIVE

When the UPS is configured to operate in SMART ACTIVE mode, it automatically selects whether to operate in ON LINE or ECO mode.

The decision is made based on statistical calculations performed by the UPS and based on the quality of the mains and bypass supplies: if the latter remains suitable for a certain period, the unit selects ECO mode, otherwise it remains in ON LINE mode.

Mode: EFFICIENCY CONTROL

In case of very low load operations, the EFFICIENCY CONTROL mode improves the total system efficiency, while preserving the ON LINE mode and the set redundancy. The algorithm behind the ECM is designed to ensure that the active modules operate close to their maximum efficiency values (between 30 to 50%), monitor the variation of the load and equalize the hours worked by each PM to ensure that all electronic components age evenly and provide dynamic performances close to ONLINE mode. The PMs that are not required to support the applied load are placed in a low consumption state. In the event of a mains power supply failure or if the power supply is not within the specified conditions, all of the PMs switch to normal ON LINE operation with double conversion. If the load suddenly and significantly increases, the system could temporarily switch to the bypass line.

EFFICIENCY CONTROL mode can be activated through HMI.

The UPS system operating mode selection, whether ON LINE, ECO, SMART ACTIVE, FREQUENCY CONVERTER, and EFFICIENCY CONTROL is shown in the “System status” LCD screen home page.

Note: The above listed operating modes are available whether a single unit, or parallel system configuration.

Note: ON LINE operating mode is the factory default setting. Any other operating mode selection is licensed to authorised service personnel only.

7. MULTI POWER PARTS DESCRIPTION

MULTI POWER2 block diagram is as follows:

MP2 300 PCM: is provided by default with manual bypass switch, single input connection and **bottom cable entry**.

Power Cabinet layout:

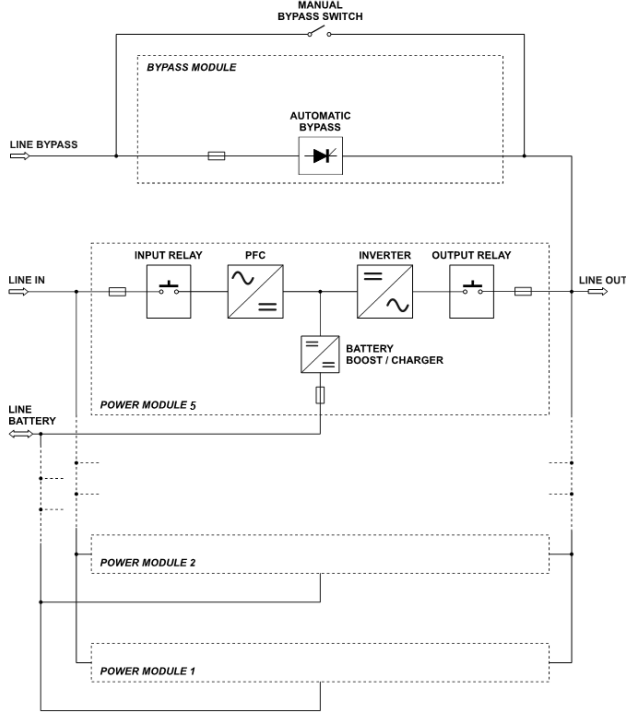

MP2 300 PCM

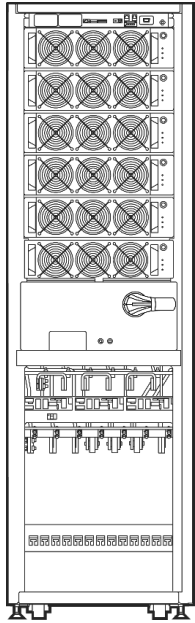

MP2 300 PCM

Dual input is available just removing the connections between the two inputs.

MP2 500 PCM: is provided by default with manual bypass switch, single input connection and **top cable entry**.

Power Cabinet layout:

MP2 500 PCM

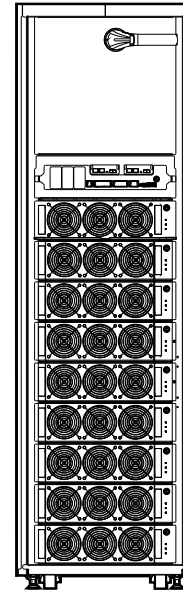
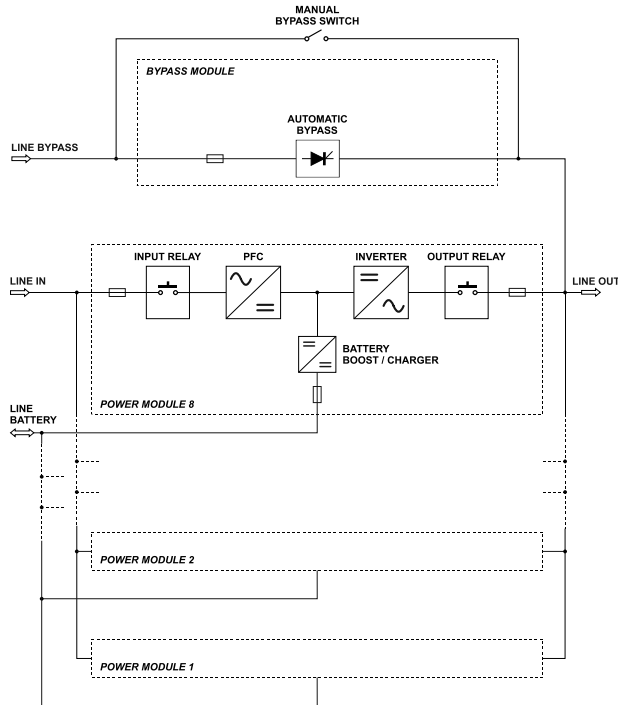

MP2 500 PCM

Dual input is available just removing the connections between the two inputs.

MP2 300 & 500 PCM Cabinets are equipped with an embedded manual bypass switch which grants continuous supply to the output terminals should there be a requirement for bypassing the system. This can be used in case of a major fault, due to bad environment, unforeseen events such as lightning and flooding which may affect system operation, or a large site upgrade. Please note that when activated the bus bars and connection terminals remain live with dangerous voltages inside the system, therefore a competent engineer should take preventive actions to prevent dangerous contact.

In order to ensure complete safe operations inside the unit an external service manual bypass is highly recommended together with the system input/output isolating devices.

MP2 600 PC0: these units are provided by default without any switch, single input connection and **top cable entry**

Power Cabinet layout:

MP2 600 PC0

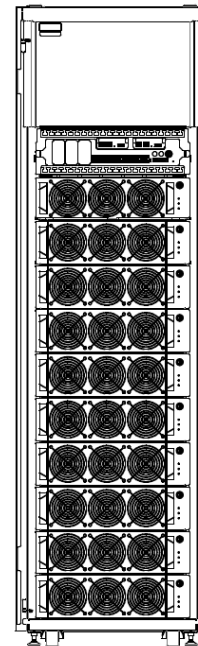
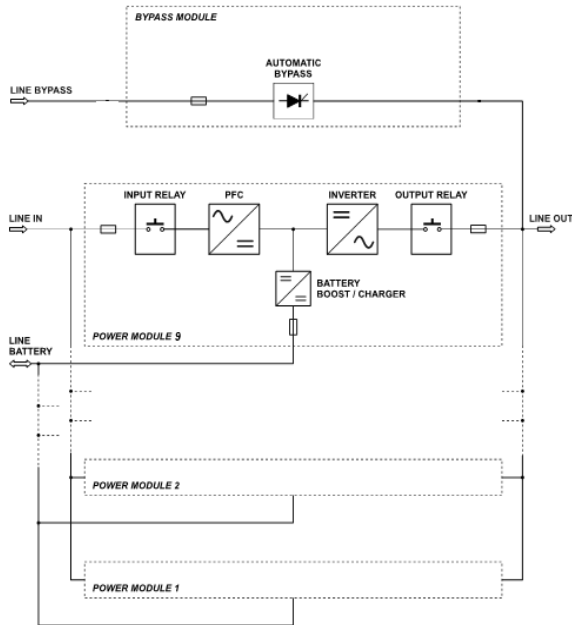

MP2 600 PC0

Dual input is available just removing the connections between the two inputs

MP2 600 PC0 VE: they have, by default, single input connection, no switches and **top ventilation and top/bottom cable entry**

Power Cabinet layout:

MP2 600 PC0 VE

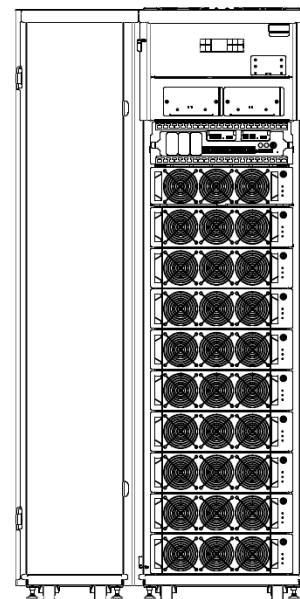
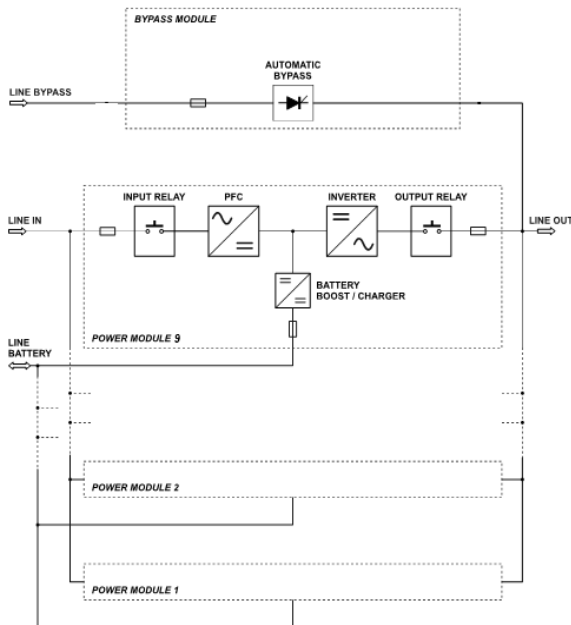

MP2 600 PC0 VE

Dual input is available just removing the connections between the two inputs.

MP2 600 PCS VE: units are provided with main input, bypass, manual bypass and output switch, single input connection, **top ventilation and top/bottom cable entry.**

For this configuration, internal backfeed protection is available as optional (from the factory).

Power Cabinet layout:

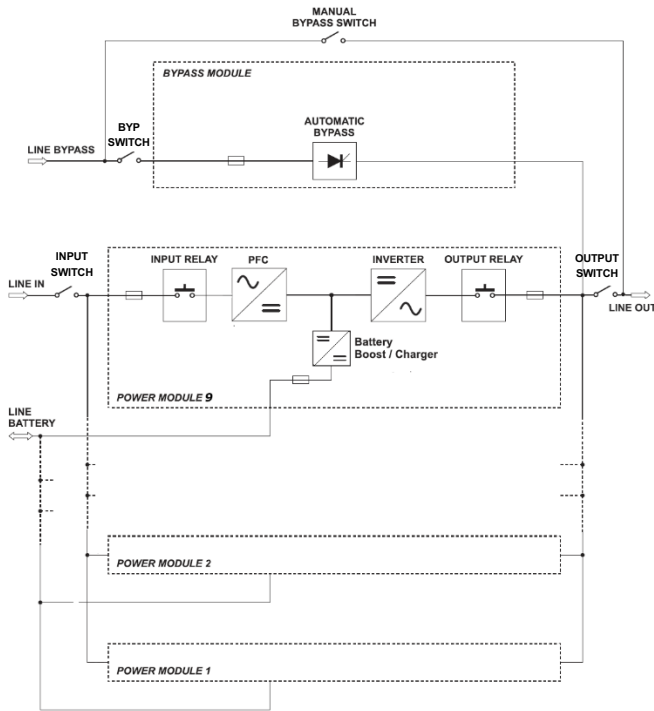

MP2 600 PCS VE

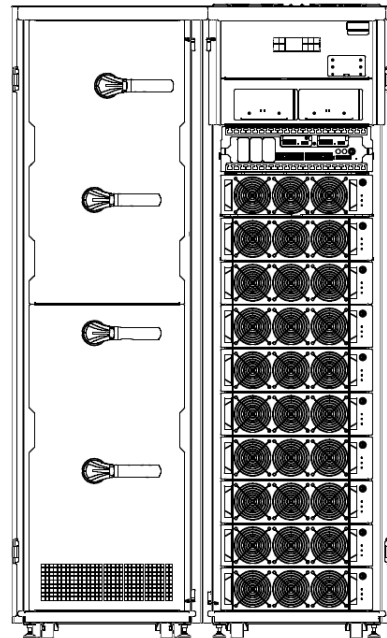

MP2 600 PCS VE

Dual input is available just removing the connections between the two inputs.

7.1 POWER MODULE (PM)

All the performance details as described below are referenced to MP2 67 PM and MP2 67 PM BLUE (here in after identified as PM) unless otherwise stated.

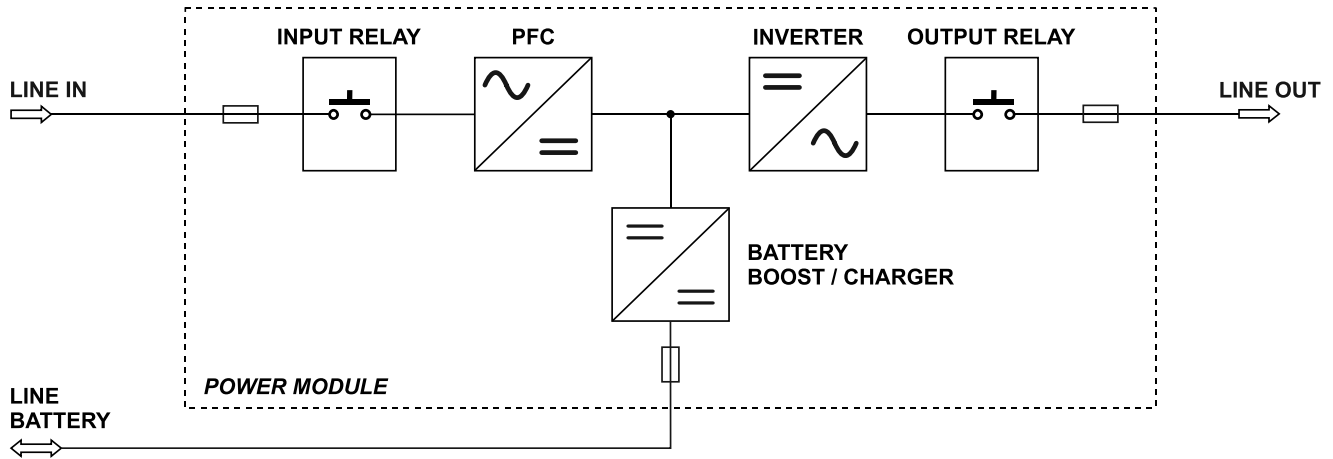

Although PM 67 and PM 67 BLUE share the same dimension and weights, the internal architecture and the main power electronic components are different:

PM 67 BLUE: is a three phase double conversion UPS equipped with:

- **Full SiC (Rectifier and Inverter);**
- Battery charger;
- Three level Inverter topology;
- Dedicated protections to prevent major failures and isolate the faulty module in case of an internal fault.



Thanks to its full SiC architecture, the module is able to reach very high efficiency in double conversion, reducing switching and operational losses compared to state of the art IGBT solutions.

PM 67 is a three phase double conversion UPS equipped with:

- Full IGBT PFC rectifier;
- Battery charger;
- Three level Inverter topology;
- Dedicated protections to prevent major failures and isolate the faulty module in case of an internal fault.



7.1.1 Overall Module Control

The PM has been developed with the most reliable and innovative technologies using power components at the cutting edge of technology and multi microprocessor architecture to ensure utmost system control, reliability and power density ensuring 67 kW at unity power factor with no de-rating up to 40°C operating temperature.

Two microprocessors oversee all the PM operations, each having different and dedicated tasks.

Furthermore, all major power components are continually temperature monitored with up to eleven temperature points. It means that all devices are working in the most optimized conditions granting STEADY and EFFICIENT operations.

The PM is equipped with three fans which are speed controlled, therefore there is no waste of energy to supply them if the load level does not require high ventilation.

At the same time each fan is equipped with a fourth 'control' wire which immediately warns the microcontroller in case of a fault; subsequently the user is immediately informed so that necessary actions can be taken to restore the complete system to correct operations.

7.1.2 Embedded Intelligence and Firmware Alignment

Intelligence is distributed avoiding any single point of failure and ensuring the optimization of the resources of each single power module, while communication between each PMs is provided by two redundant buses, providing a resilient and high-speed connection.

The integration of the state-of-the-art hardware together with the latest firmware releases introduces several new features especially during the insertion and start-up of the power modules.

To ensure that the introduction of a new module won't affect the power quality supplied to the critical loads or the integrity of the system, a series of automatic health-checks are performed during the plug-in of each module to verify its status and avoid defective components.

If a new module has a different firmware version, the system, after confirmation by the user, aligns it to the one of the other modules already in operation.

Operation is completely risk-free and enables the user to increase the power or redundancy of the system while the UPS is protecting the load.

7.1.3 PFC Input Converter

The PFC Converter (AC/DC) converts the AC voltage into a DC supply to power the Inverter; if the mains or alternative power supply fails, the Converter will raise the battery voltage to a value suitable to power the Inverter.

The input converter is a three phase plus neutral type; if utility supply phase rotation is not correct, the converter will continue to operate but warn the user of the error via a dedicated alarm.

In addition, if one or two of the supply input phases are missing the system may continue taking power from the mains (not absorbing energy from the batteries) depending on the load level (refer to the technical table).

According to the PM selected and therefore the efficiency needed, the rectifier could use IGBT power semiconductors (PM 67) or SiC components (PM 67 BLUE).

The PFC control technology benefits from Digital Signal Processor (DSP) microprocessor, advanced Programmed Logic Device (PLD) and latest generation of power semiconductors to achieve a low impact on the power supply source, low harmonic distortion and high input power factor.

The UPS negligible input harmonic distortion of 3% and high input power factor (> 0.99); make it possible to reduce the size of a possible generator and/or a distribution transformer MT/BT placed upstream.

A zero impact on the supply source is ensured, due to the following configurable operational control parameters:

- **Power Walk in-start Delay (t1-t0):** when the mains power supply returns, this parameter delays the input stage start up for a period of time that can be set between 0 and 120 seconds. This function is particularly useful when the mains power supply returns after an interruption (or when the generator set is started) and the source is required to supply various UPS or, more typically, multiple loads.
- **Power Walk-in duration (t2-t1):** when the mains power supply returns, absorption of the mains power supply progressively reaches the nominal value within a time period that can be set from 1 to 120 seconds. This function is normally disabled but whether active or not the UPS maximum input current (Inrush) is always limited and never greater than the nominal current.

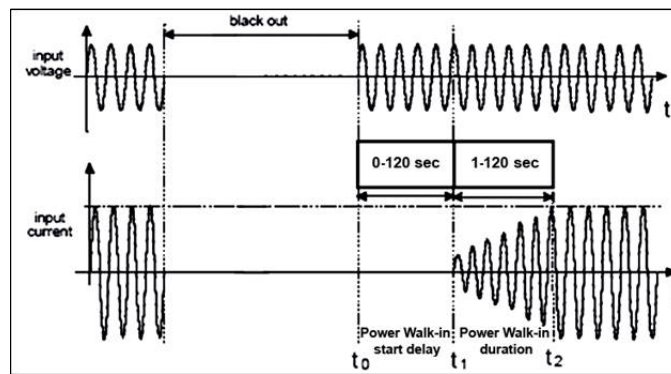

7.1.4 Inverter

The DC/AC Converter (Inverter) converts the direct current into a stabilised sinusoidal alternating current to power the load. When the UPS is in ON LINE mode, the load is always powered by the Inverter.

PM 67 has an Inverter with IGBT (Insulated Gate Bipolar Transistor) based three-level design while the inverter of PM 67 BLUE has Silicon Carbide Mosfets.

IGBT is a transistor that allows high commutation frequencies (18 kHz) and, as a result, the Inverter provides a high-quality output voltage, with low noise levels and state-of-the art operating efficiency.

SiC devices works at the same frequency (18 kHz) of IGBT but with less operational and switching losses compared to our standard solution, bringing a sensitive increase of the overall efficiency of the system.

Whatever module is used, DSP microprocessor controls guarantee static and dynamic excellent performances under any operating condition:

Voltage adjustment

The output voltage can be adjusted using the independent phase control and DSP microprocessor; this enables a better static and dynamic response. In detail:

- static condition:** the Inverter output voltage remains within $\pm 1\%$ for all variations of the input voltage within the accepted limits;
- dynamic condition:** for load variations from 0 to 100%, the output voltage remains within the most stringent limits defined by class 1 of the EN 62040-3 standard.

Frequency adjustment

The Inverter output frequency is generated autonomously by an internal oscillator, in synchronisation with the bypass supply. Frequency stability is operating condition dependent:

c) Frequency stability

- a. With mains power present: the internal oscillator follows any frequency variations in the bypass supply and in relation to the preset value - normally $\pm 5\%$ (configurable from $\pm 0.25\%$ to $\pm 10\%$).
- b. With no supply present: the Inverter autonomously generates the frequency of the output voltage with a stability of $\pm 0.01\%$.

d) Frequency variation speed

The maximum Inverter output frequency variation (to lock to that of the bypass supply) is 1 Hz/s (adjustable from 0.5 to 2 Hz/s).

Distortion of the output voltage

Inverter output waveform distortion with a linear load is maintained $< 1.5\%$. Within a non-linear load, as defined by the EN 62040-3 standard, output voltage distortion does not exceed $\pm 3\%$.

Overload and Short circuit current

If a current surge occurs whilst the UPS is operating, the Inverter will carefully analyse the output voltage and current to distinguish if the short circuit is genuine or an overload.

As for the overload limits refer to the technical data table. If the UPS detects a short circuit (VOUT < 100 Volt and overload status):

- During battery operation (bypass power supply failure), the Inverter can supply a fault current (current limited) up to 250% for 100 ms and after that, (if the short circuit has not been cleared) an additional 150% for 400 ms.
- When the mains power supply is present, the Inverter will switch to bypass; the UPS will continue to feed the fault according to a specific current-related function (see technical data for further details).

The table below recommends the sizing of the various protection devices located downstream of the UPS in order to guarantee their selectivity even in the event of a power failure:

Output protections (values recommended for selectivity)	
Rapid fuses (GI / gG)	I_n (Nominal current)/4
Magneto thermal switches (Curve C)	I_n (Nominal current)/4

Output voltage symmetry

Under all conditions, output voltage symmetry is maintained within $\pm 1\%$ for balanced loads and $\pm 2\%$ for unbalanced loads of 100% (e.g. one phase with nominal load and the other two with no load).

Phase shift angle

The three-phase Inverter output voltages have a guaranteed phase separation angle of $120^\circ \pm 1^\circ$ for balanced loads and for 100% unbalanced loads.

Output power

The Inverter is sized to supply 100% of active power with a nominal load PF of 1 within the operational temperature range without any downgrading. Multi Power2 can supply capacitive and inductive load loads up to PF 0.7 without any power derating.

7.1.5 Battery Charger (Battery Care System)

The "Battery Care System" is a set of functions arranged to help extend the working life of the battery set and optimise its performance. Each Power Module is equipped with a battery charger able to provide up to 30 A. All chargers combine to recharge the UPS batteries.

Battery recharging: the UPS can be used with sealed lead batteries (VRLA), AGM, open-vented, Li-Ion and NiCd batteries. According to the type of battery used several recharge methods are available (below data are referred to a string with 40 VRLA batteries):

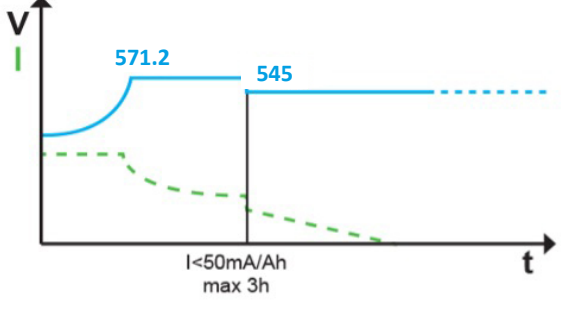
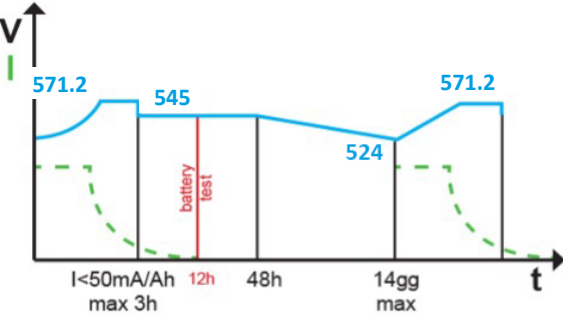
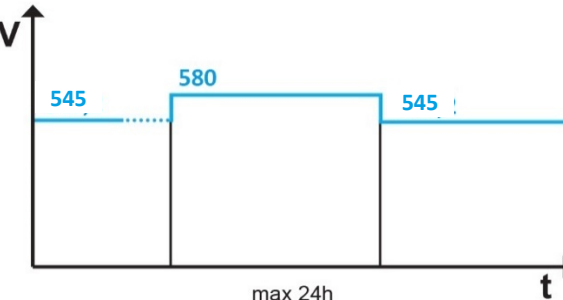
Recharging modes (selectable by "Service SW")	MULTI POWER2 configurations
	<p>Floating (configurable): the charge state of the battery is continuously monitored; when the mains power supply is present, the batteries are charged at a preset voltage level and limited current relative to the recharge time required and the capacity of the battery itself.</p>
	<p>Two-level (standard configuration): this recharge is at limited current with two levels of voltage. In the first instance, the process uses a quick charge voltage, whilst in the second stage a float charge. This type of charging is mainly used with open-vented batteries or other types when an accelerated recharge time is required.</p>
	<p>Cyclical (configurable): this recharge is sometimes recommended by battery manufacturers to prolong the battery life. It consists of battery charge and discharge cycles as indicated in the diagram.</p>
	<p>"Commissioning" (configurable): this charge method is useful every time new batteries are installed in the UPS. By increasing the voltage to 580 Volt for a maximum of 24 hours, perfect equalisation of the battery charge is assured, thus guaranteeing a uniform discharge and wear of the battery monoblocks.</p>

The various recharge methods and the preset voltage values are defined using “Service SW”.

The presence of the external temperature sensor option will activate compensation of the voltage depending on the temperature (The sensor shall be enabled through UPS System configuration).

- a) **Battery test:** during normal operation the battery is automatically tested at regular intervals. The battery test can also be manually activated. The test is performed to ensure a limited battery discharge and impact on overall life expectancy. If the test returns a negative result a warning is displayed on the UPS panel (or remote panel, if installed).
- b) **Protection against slow discharges:** for long runtimes and low load discharges, the end of discharge voltage is raised to approximately 1.8 V/ℓ as recommended by the battery manufacturers to avoid a deep discharge state.
- c) **Ripple current:** recharge ripple current (residual AC component) is one of the most important causes of poor battery reliability and reduced operating life. The UPS battery charger is a high-frequency design with a negligible level of ripple current.
- d) **Battery recharge limit current:** The battery recharge current is limited to a prefixed value of $C_{nom}/8$ (i.e. 12.5% C_{nom}).
- e) **UPS without batteries:** the UPS must always operate with the batteries connected; if they are not connected alarms will be generated and the UPS will not be able to perform to specification ensuring business continuity. However, if the system is to operate as a frequency converter a battery is not mandatory.

7.2 BYPASS MODULE (BM)

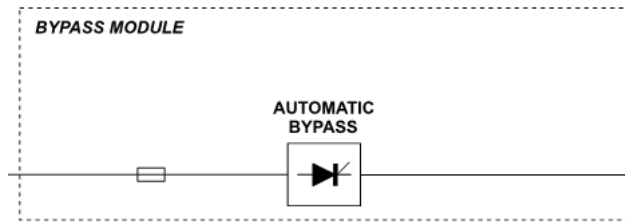

MP2 500 Amp BM

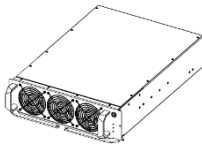

MP2 500 BM

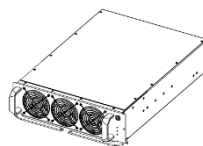

MP2 600 BM

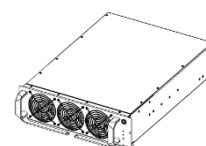

The bypass static switch is a high speed, solid-state transfer device rated for continuous duty operation. Transfer operations will be provided by the electronic static switch which take place automatically in the event of:

- Output voltage outside the limits
- Over-temperature
- Number of modules isn't enough to sustain the load in double conversion.

As soon as the mains supplies the load (via bypass) all the disturbances such as voltage and frequency variations effect the load.

The uninterrupted automatic transfer may be inhibited in the following situations:

- If at the time of switchover, the Inverter voltage is not synchronized with that of the bypass line power supply. The transfer will take place with a delay of around 20 ms; in consideration of the various types of loads, this delay can be set with "Service SW" (10-100 ms) or the switchover can be inhibited if there is no synchronization.
- Manual switching to bypass supply via the maintenance switch.
- If the system operates as frequency converter.

Each Multi Power2 comes with its own swappable Bypass Modules with a specific power ratings, according to the cabinet nominal power (300 kVA – 500 kVA – 600 kVA).

Unlike PM, BM is always included as part of the UPS system.

(Refer to the technical table for details).

Fuse protection

Each bypass module has embedded input fast fuses to meet the following Icc values:

MP2 300 PCM:

- 100 kA in case the manual bypass is excluded
- 50 kA with the use of manual bypass (SWMB) and external protection fuses (500 A gG)
- 10 kA with the use of manual bypass

MP2 500 PCM:

- 100 kA in case the manual bypass is excluded
- 65 kA with the use of manual bypass

MP2 600 PCO/PCS:

- 100 kA in case the manual bypass is excluded or not present
- 65 kA with the use of manual bypass

Please refer to Installation Manuals for further details.

Backfeed protection

The UPS has internal protection against backfeed. This protection acts by means of a sensing circuit which turns the inverter off if a fault within the static switch is detected. During this condition, to avoid interrupting the supply to the connected load, the UPS switches to the bypass line.

If this fault occurs during battery operation, the inverter is stopped.

A volt free contact can be configured to drive a disconnecting device to be installed upstream of the bypass input to the UPS, in this case when a backfeed fault occurs, the system opens the external disconnecting device, hence avoiding the requirement to stop the inverter (refer to specific software configuration).

For MP2 600 PCS VE configuration there is the possibility to integrate a backfeed protection device replacing the bypass switch as per the figure below.

If a backfeed is detected the control system will trip the backfeed switch and force the UPS to supply the load from the inverter only

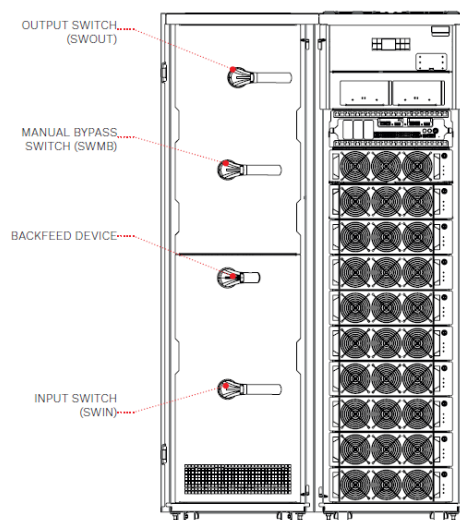

MP2 600 PCS VE + Backfeed

Bypass power supply limits

Transfer to the bypass line takes place if the voltage and the frequency are considered 'suitable' for the load and the limits for transfer can be set on-site by the UPS user.

Voltage range: $\pm 10\%$ (configurable from -20% to $+15\%$);

Frequency range: $\pm 5\%$ (configurable from $\pm 0.25\%$ to $\pm 10\%$)

Overload

The UPS static switch is sized to support the following overload periods; above these limits the UPS is automatically turned Off:

- 110% for 1 hour
- 125% for 10 minutes
- 150% for 1 minute

Note: for further overload limit details, clearing I^2t energy and rated conditional short circuit current (I_{cc}), refer to the technical data table.

Dedicated Power Supply for the BM

BM unit is equipped with a dedicated power supply to allow the automatic bypass to operate independently from other system power supplies, granting a higher bypass system reliability and system operation.

8. DISPLAY AND STATUS LED

The control panel consists of a 10" touchscreen graphic display and multicolour status LED placed below the display which delivers immediate and clear information regarding the overall status of the UPS by changing the colour (light blue, dark blue, orange and red) according with the operating mode and condition.

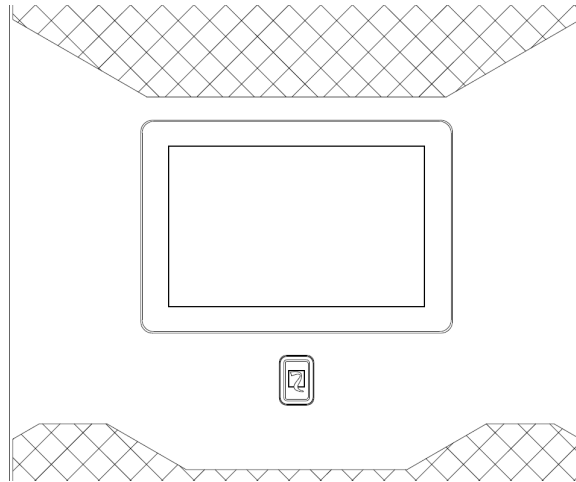

The 10" touchscreen display is installed in the front door of the UPS and it's replaceable (hot swap) in case of need, while the unit is working in ON LINE mode.

It allows the user (according with access profile) to easily:

- Identify the energy path through the UPS.
- Monitor the overall system status and single module status (PM, BU, BM).
- Send start /stop, battery test, bypass command.
- Set up the system: parameter configuration, operating functions, web and mail services, access levels.

Graphic display provides UPS information, measurements, operating states, alarms and configuration in different languages.

Multilevel access menu grants easy, intuitive and secure access to information, measurements, and configurations, for both service personnel and user according with the profile.

8.1 DISPLAY

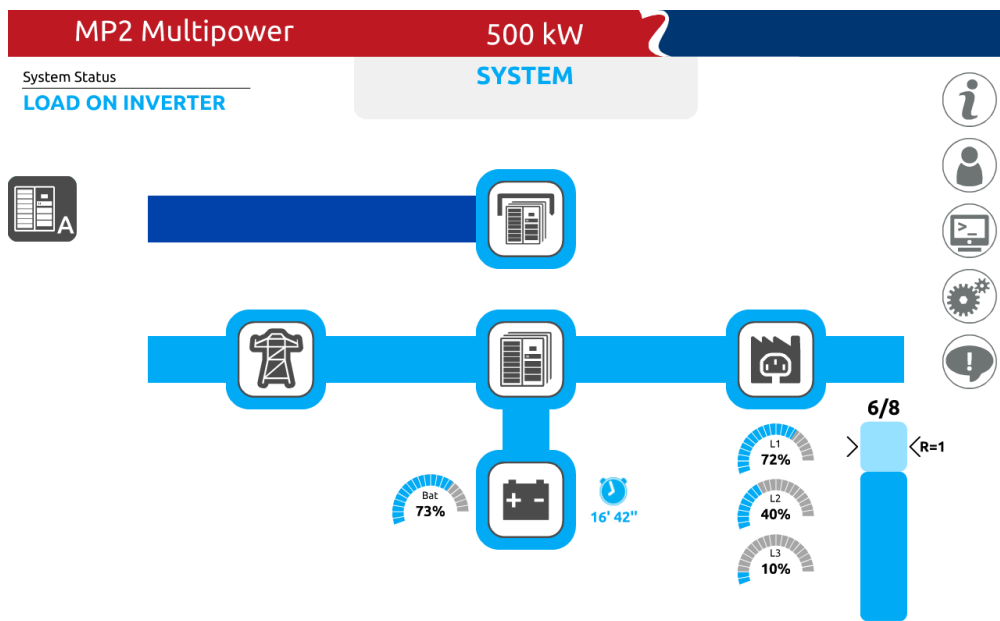

As Multi Power2 is a modular UPS, the information is structured in such a way that the user can see both the detailed data and parameters of each module and, also, a more general view of the entire system, to see, at a glance, the operating mode and the status of the unit.

The home page provides a graphic bar showing the load level and the system redundancy:

Load level: The bar is a comprehensive representation of the number of PM set including their status in terms of load level and operational conditions.

Redundancy: To increase the system reliability the customer can add a number of additional PM (redundant PM) rather than just fit those strictly necessary to supply the load.

All PM, including the redundant units operate together sharing the load.

It is highly recommended to set one or more redundant PM according with the power needed and the installation type; hence with any Power Cabinet fully equipped at least one unit should be set as a redundant unit.

The load percentage is referred to the power of the unit configured during the start up.

8.1.1 Display Icons, Symbols and Texts

The main active icons present in the diagram are:

Mains input	Output	Battery	Automatic static bypass	System status

Tapping each icon, it is possible to collect the UPS measurements and particularly:

System input/mains icon: Input voltage plus input current and frequency;

System output icon: Output voltage, rms and peak current, power (kW/kVA/pf);

Bypass icon: Input voltage phase to phase and phase to neutral plus frequency;

Battery icon: Battery voltage and current, charging level and autonomy time.

The icons can be highlighted by several colours, according to the status of the UPS:

Grey: communication lost (Com-Lost)	Light blue: ON LINE Mode	Blue: load on bypass	Orange: anomaly	Red: alarm

Colored bars indicate the route that power is following in the system:

	Normal mode. The power goes from input to load through UPS that loads battery if they are connected.
	Working on Bypass. Power flows through static bypass or manual bypass.
	Battery working. Power flows from battery to load through UPS. Pay attention to back-up time and charge percentage of the battery.
	Manual bypass.

In addition to the main diagram, there are additional information icons:

% Battery charge gauge
it represents charge percentage of the battery

Back-up time estimate
The calculus of back-up time is function of applied load and the battery charge status

L1
 L2
 L3
% Load gauge phase 1, 2, 3 referred to the system power

Redundancy bar
see user manual for more info

8.1.2 Active Text Areas

Parallel System Status

ON LINE

At the top left of the display, active area which reports the current state of the SYSTEM.

POWER MODULE
[A.1.1]

At the top center of the display, active area showing the name and possibly the address (A, B, C, D) of the SYSTEM, UPS or Module being viewed.

Ups Status
MANUAL BYPASS ACTIVE

At the top right of the display, active area which reports the current status of the selected UPS or Module (present only when the UPS or Module tabs are displayed).

8.1.3 UPSs List



Address list of all UPSs of the SYSTEM. Every UPS that composes the system has a unique address (identified to a letter from A to D). The written LOCAL informs that this display belongs to this specific SYSTEM.



These symbols may appear inside the icon, which identify a particular state of the related UPS:

	Anomaly present		Alarm present
--	-----------------	--	---------------

8.1.4 Menu:

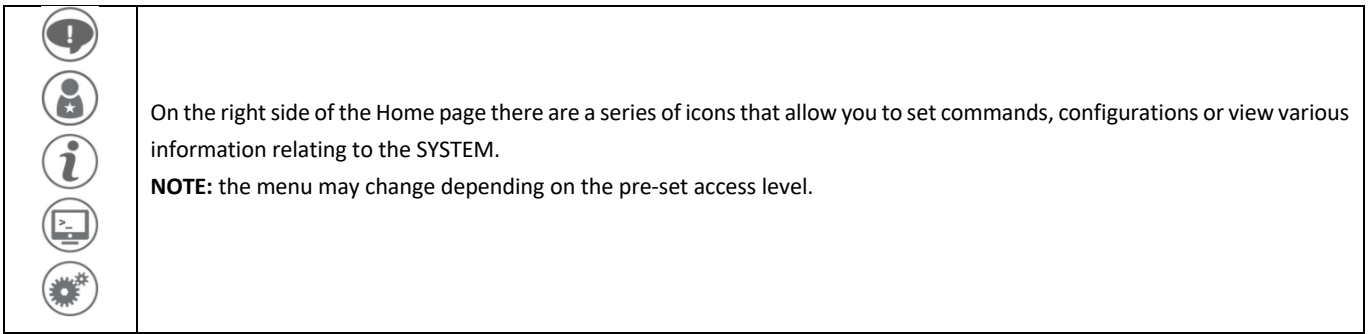

Notifications/alarm



Access level selection

NOTE: the icon changes depending on the preset access level (see “Access level selection” paragraph in the user manual)



Global System information



Command panel



NOTE: available only with “Power User” or “Expert” access level



Settings menu

NOTE: available only with “Power User” or “Expert” access level

in the various pop-up screens, on the right side at least one of these icons will always be present:

-  button to exit the active pop-up screen (any changes will not be saved)
-  button to confirm any insertion and/or modification operations

Note: For more information about the display menu and operations refer to the UPS user manual.

8.2 STATUS LED

Below the touch screen display, an illuminated Riello UPS logo will inform the user at a glance, about the status of the UPS. The operational conditions are indicated via the various colors as follows. For further details refer to UPS user manual.

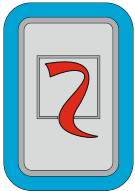

Light blue (pulsing): Normal operation

No anomalies are present, and the system is working in the selected mode.

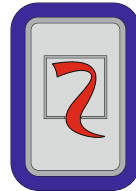

Dark blue: Bypass operation

The system is working from a temporary bypass.

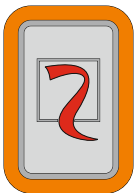

Orange: Anomaly

The system is working from battery, forced to bypass or an anomaly or warning has occurred.

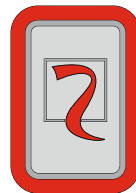

Blinking red: Fault condition

A fault or lock occurred, or the load is not powered due to an unexpected condition (e.g. Emergency Power Off).

9. CONNECTIVITY PANEL

Connectivity Panel encompasses all the communication interfaces and host the parallel slots, it is available in two different versions, one dedicated to MP2 300 PCM and the other for MP2 500 and 600 units.

Thanks to this component the Multi Power2 is aware about the information coming from the installation and is able to provide data and other operational information to the Customer.

9.1 CONNECTIVITY PANEL FOR MP2 300 PCM

Thanks to this component MP2 300 PCM is aware of the information coming from the installation and is able to provide data and other operational information to the Customer.

The Connectivity Panel includes the System Monitoring Unit (SMU), a microprocessor-controlled board dedicated to the management of input and output signals, such as temperature sensors, status of external switches (if any), communication boards and it is also responsible of the operation of the display.

Even this item, in case of a fault, immediately warns the user and the replacement procedure can be performed easily while the UPS is running in online double conversion.

It is provided with:

- 1 NETWORK communication slot with already installed NetMan 208 and installed inside the CP.
- 1 slot for communication boards (refer to paragraph 9.1.4 – 9.3 – 13.5).
- 1 slot suitable to host relay card (refer to paragraph 9.1.4 – 9.3 – 13.5).
- 5 input and 4 output signals, configurable.
- Auxiliary output terminals to manage backfeed and battery disconnection commands and an input signal for the temperature sensor (“AUX” section).

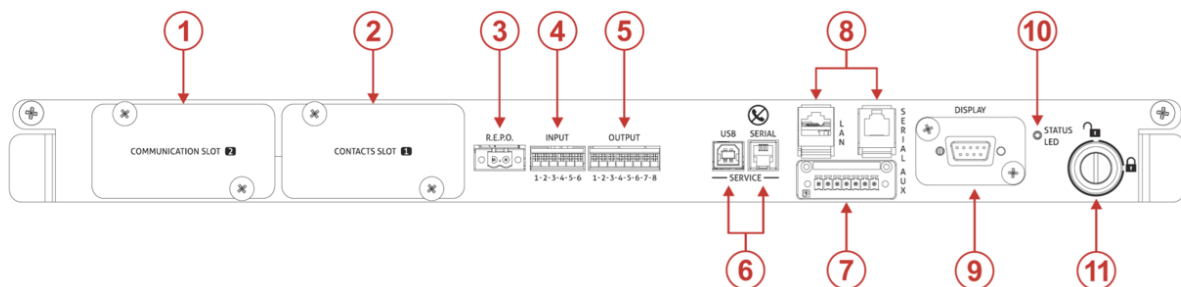

- | | | | |
|---|-----------------------------|---|-----------------|
| ① | Communication Slot (SLOT 2) | ⑧ | NETMAN port |
| ② | Contact Slot (SLOT 1) | ⑨ | Display port |
| ③ | R.E.P.O. | ⑩ | SMU status LEDs |
| ④ | Signal input | ⑪ | Switch Lock |
| ⑤ | Signal output | | |
| ⑥ | Service ports | | |
| ⑦ | Signal AUX | | |

9.1.1 R.E.P.O

This insulated input is used to switch off the UPS in an emergency. The UPS is supplied from the factory with a “remote Emergency Power Off” (R.E.P.O.) terminals short-circuited.

When activated from a remote push-button or other device in an emergency, the R.E.P.O connection will open and the UPS will shutdown. The UPS no longer powers the load.

The R.E.P.O circuit is supplied with SELV type circuits. No external supply voltage is required. When it is closed (normal condition), a maximum current of 10 mA flows.

After an emergency shutdown, the UPS will only return to ON LINE operating mode once it receives a start-up command from the mimic panel (provided that the Remote Emergency Power Off device is not still active).

9.1.2 PROGRAMMABLE IN – OUT SIGNALS

All input signals can be programmed using the service configuration software (reserved to service personnel only);

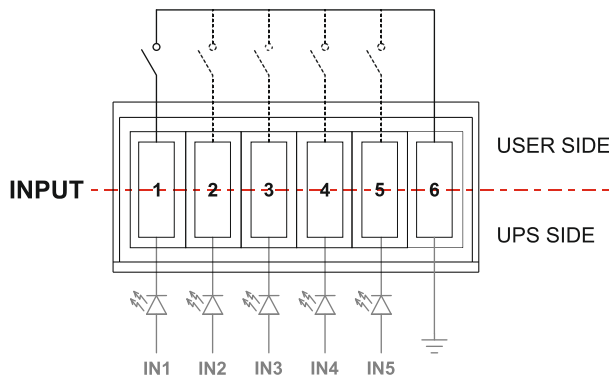

FACTORY DEFAULT SETTING

INPUT	FUNCTION
IN 1 #	-
IN 2 #	CB OFF
IN 3 #	Battery test
IN 4 #	Position of the External SWBAT
IN 5	Position of the External SWMB

These inputs must be enabled from the display panel

Although all the output signals can be programmed using the service configuration software (reserved to service personnel only), they have a standard factory configuration:

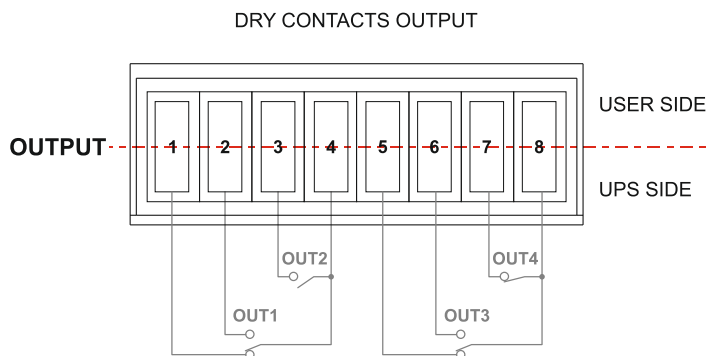

FACTORY DEFAULT SETTING

OUTPUT	FUNCTION
OUT 1	Load on Bypass
OUT 2	Battery Working
OUT 3	Battery Low
OUT 4	Fault or Lock (F+L)

The output dry contacts are rated to:
1A @ 24Vdc or 1A @ 30Vac

9.1.3 AUXILIARY SIGNALS

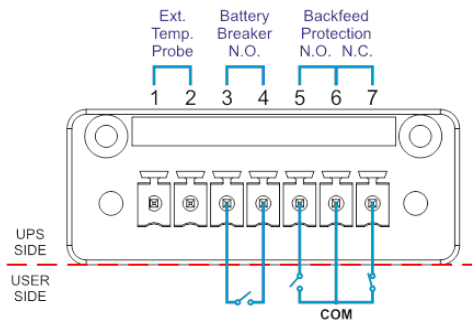

EXTERNAL TEMPERATURE PROBE

Input to connect the external probe to measure the battery temperature. Please refer to the optional kit.

EXTERNAL BATTERY BREAKER

Output (default N.O.) to manage the opening of the external battery disconnecter switch. The contact closes if EPO is activated. This dry contact is rated to: 1A @ 24Vdc or 1A @ 30Vac.

BACKFEED PROTECTION

Output (N.O. or N.C.) to manage the opening of an external disconnecter switch in case of a backfeed fault occurs. This dry contact is rated to: 1A @ 24Vdc or 1A @ 30Vac.

For further information please refer to the installation manual.

9.1.4 COMMUNICATION SLOTS

SLOT 1 – Contacts Slot

Slot to accommodate the relay cards (no communication cards).

SLOT 2 - Communication Slot

Slot to host communication cards (no relay cards).

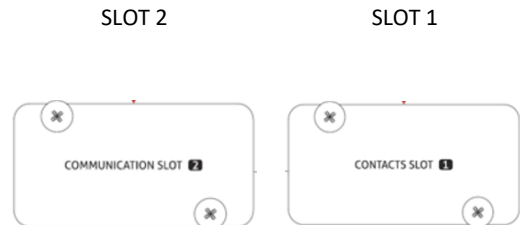

Please refer to the related manual for further information

9.2 CONNECTIVITY PANEL FOR MP2 500 AND MP2 600

Connectivity panel for MP2 500 and MP2 600 units is provided with:

- 1 NETWORK communication slot with already installed NetMan 208.
- 2 Communications slots with possibility to install several communication cards (refer to paragraph 9.2.5 – 9.3 – 13.5).
- 10 input signals: 5 inputs are already configured in the factory, by default, to monitor the auxiliary external switches if present (SWIN, SWBYP, SWBATT, SWMB, SWOUT), while the other 5 are spare. The configuration done in the factory can be changed on site in case of specific requirements.
- 8 output signals, configurable.
- Two auxiliary output terminals to manage backfeed and battery disconnection commands and an input signal for the temperature sensor (“AUX” section).

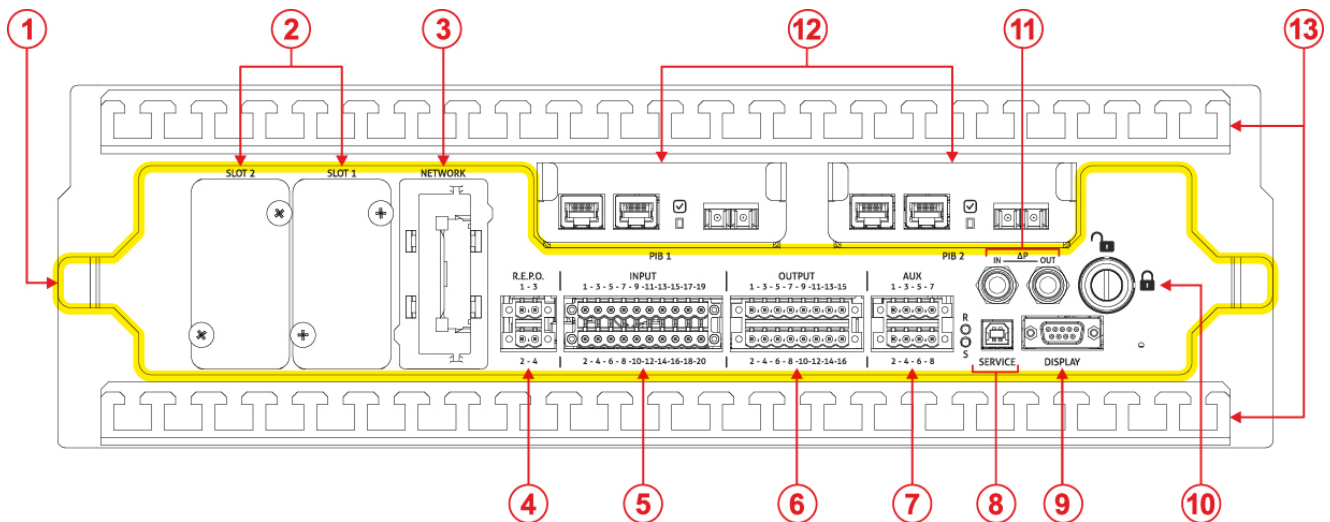

- | | |
|---|--|
| ① SMU (System Monitoring Unit) | ⑧ Service port |
| ② Communication Slots (SLOT 1 - SLOT 2) | ⑨ Display port |
| ③ Network | ⑩ Switch Lock |
| ④ R.E.P.O. | ⑪ Pressure sensor |
| ⑤ Signal input | ⑫ Parallel interface boards (PIB 1 – PIB 2) [option] |
| ⑥ Signal output | ⑬ Wiring ducts |
| ⑦ Signal AUX | |

9.2.1 SYSTEM MONITORING UNIT

The System Monitoring Unit (SMU) is microprocessor-controlled board dedicated to the management of input and output signals, such as temperature sensors, status of external switches (if any), communication boards and it is also responsible of the operation of the display.

Even this item, in case of a fault, immediately warns the user and the replacement procedure can be performed easily based on a hot swappable principle.

9.2.2 R.E.P.O

This insulated input is used to switch off the UPS in an emergency. The UPS is supplied from the factory with the series of two independent Remote Emergency Power Off" (R.E.P.O.) terminals short-circuited.

When activated from a remote push-button or other device in an emergency, the R.E.P.O connection will open and the UPS will shutdown. The UPS no longer powers the load.

The R.E.P.O circuit is supplied with SELV type circuits. No external supply voltage is required. When it is closed (normal condition), a maximum current of 10 mA flows.

After an emergency shutdown, the UPS will only return to ON LINE operating mode once it receives a start-up command from the mimic panel (provided that the Remote Emergency Power Off device is not still active).

9.2.3 PROGRAMMABLE IN – OUT SIGNALS

All input signals can be programmed using the service configuration software (reserved to service personnel only); the input 6, 7, 8, 9, 10 have a standard factory configuration.

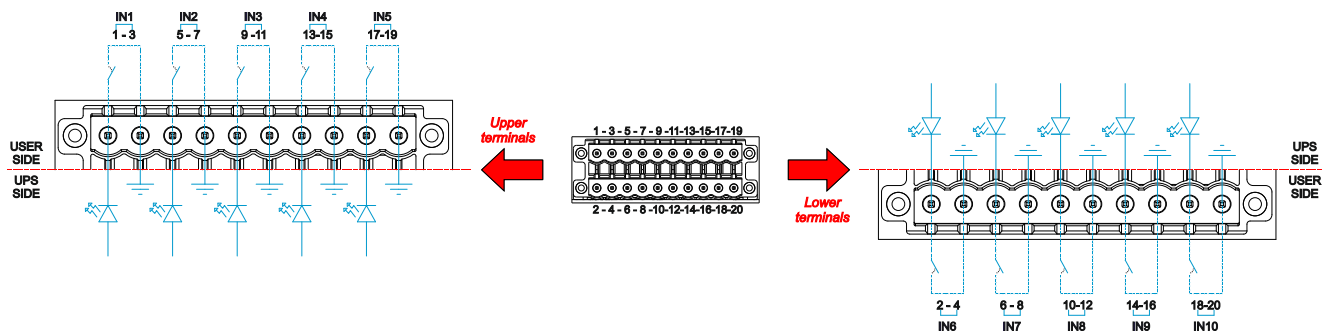

FACTORY DEFAULT SETTING

INPUT	FUNCTION
IN 1, 2, 3, 4, 5	Not programmed
IN 6	Auxiliary of External Input Switch (N.C.) When the SWIN is open the relative auxiliary contact must be closed
IN 7	Auxiliary of External Manual Bypass Switch (N.C.) When the SWMB is open the relative auxiliary contact must be closed Note: if it's not used, the jumper must remain fitted
IN 8	Auxiliary of External Bypass Switch (N.C.) When the SWBY is open the relative auxiliary contact must be closed
IN 9	Auxiliary of External Battery Switch (N.C.) When the SWBATT is open the relative auxiliary contact must be closed
IN 10	Auxiliary of External Output Switch (N.O.) When the SWOUT is open the relative auxiliary contact must be opened Note: if it's not used, the jumper must remain fitted

The input dry contacts are rated to: 1A @ 24Vdc or 1A @ 30Vac

Although all the output signals can be programmed using the service configuration software (reserved to service personnel only), they have a standard factory configuration:

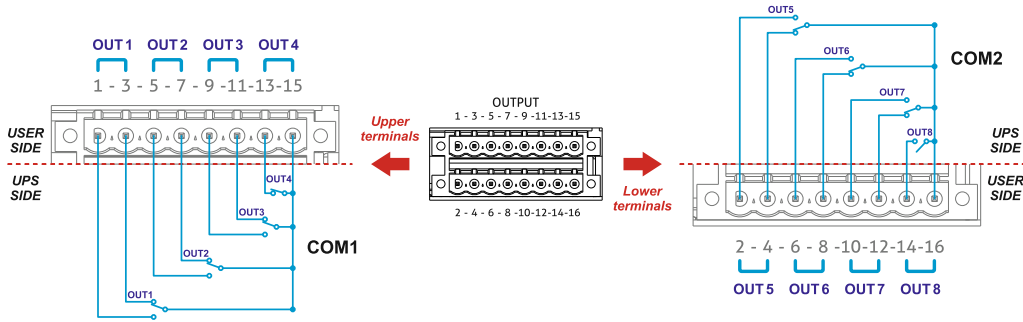

OUTPUT	FUNCTION	CONTACTS	STATUS
OUT 1	Load on Bypass	1-15	⇒ closed
		3-15	⇒ open
OUT 2	Battery Working	5-15	⇒ closed
		7-15	⇒ open
OUT 3	Battery Low	9-15	⇒ closed
		11-15	⇒ open
OUT 4	Fault or Lock (F+L)	13-15	⇒ open
OUT 5	Battery Fail	2-16	⇒ closed
		4-16	⇒ open
OUT 6	Lost Redundancy	6-16	⇒ closed
		8-16	⇒ open
OUT 7	Output Powered	10-16	⇒ closed
		12-16	⇒ open
OUT 8	Normal Operation	14-16	⇒ closed

The output dry contacts are rated to:
1A @ 24Vdc or 1A @ 30Vac

9.2.4 AUXILIARY SIGNALS

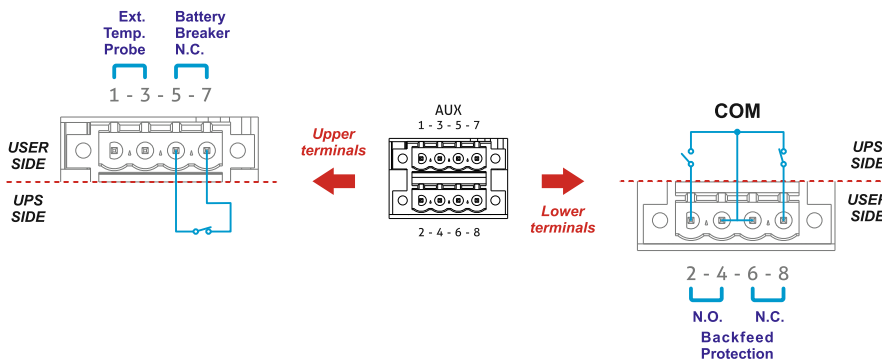

EXTERNAL TEMPERATURE PROBE

Input to connect the external probe to measure the battery temperature. Please refer to the optional kit.

EXTERNAL BATTERY BREAKER

Output (default N.C.) to manage the opening of the external battery disconnecter switch. The contact open, for instance, when the emergency power off (EPO) is activated or when an abnormal condition is detected near the DC connectors. This dry contact is rated to: 1A @ 24Vdc or 1A @ 30Vac.

BACKFEED PROTECTION

Output (N.O. or N.C.) to manage the opening of an external disconnecter switch in case of a backfeed fault occurs. This dry contact is rated to: 1A @ 24Vdc or 1A @ 30Vac.

For further information please refer to the installation manual.

9.2.5 COMMUNICATION SLOTS

The UPS is provided with three communication slots which can be used to host optional communications cards. The slots are not interchangeable.

NETWORK SLOT

Slot to accommodate the network card – NetMan 208.

SLOT 1 – Communication Slot

Slot to accommodate the communication cards (no contact or relay cards).

SLOT 2 - Communication and Contacts Slot

Slot to host additional communication cards (default configuration) or contact/relay expansion cards.

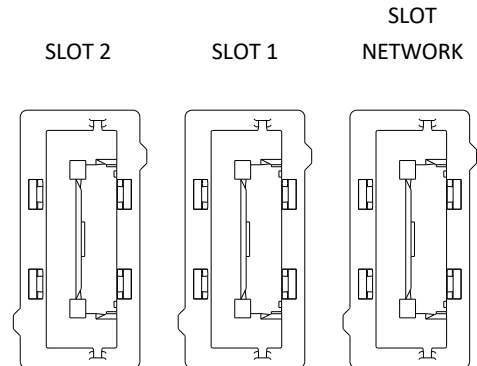

Please refer to the related manual for further information.

9.2.6 AIR PRESSURE SENSOR

Dedicated sensor to measure the pressure difference before and after the door to understand the status of the air filter.

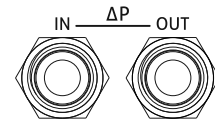

The following components are common between all the Connectivity Panel and so shared between all the MP2 units.

9.3 COMMUNICATION CARDS

The two expansion slots 1-2 available (the third one hosts NetMan 208 in standard) are compatible with variety of communications options, including:

- Additional RS232 port
- Ethernet network agent with TCP/IP protocol, HTTP and SNMP
- RS232 + RS485 port with MODBUS protocol
- EnergyManager card to be used for Li-Ion batteries (see paragraph 13.6)

Communication slot labelled as “2” is suitable to host the relay cards MULTICOM 392 (**three** opto insulated inputs and **eight** programmable volt free output contacts 25 Vac / 30 Vdc, 1 Amp)

In order to carry out card installation and configuration refer to the specific cards dedicated user manual.

For further accessory information and compatibility with the product please visit our website.

9.4 DISPLAY PORT

Port providing data and power supply to display.

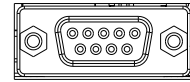

DISPLAY

9.5 USB (service port)

This port is dedicated to service personnel to connect the UPS to PC for service configuration or firmware update.



SERVICE

9.6 PARALLEL CARD

Whenever units are connected in parallel to achieve higher power availability or redundancy, the parallel card ensures the communication between the units. For further information refer to paragraph 11.1 (MP2 300 PCM), 12.1 and 12.2 (MP2 500 and 600) and the specific parallel card installation manual.

10. STANDARD FEATURES

10.1 FRONT DOOR AIR FILTER

All MP2 500 and 600 units are provided with embedded air filter installed in the front door in correspondence of power modules and bypass modules. The status of the air filters is monitored by a dedicated air pressure sensor installed in the connectivity panel. This sensor detects the pressure difference between the air before and after the filter itself. An alarm is raised in case the value detected is outside the operational threshold.

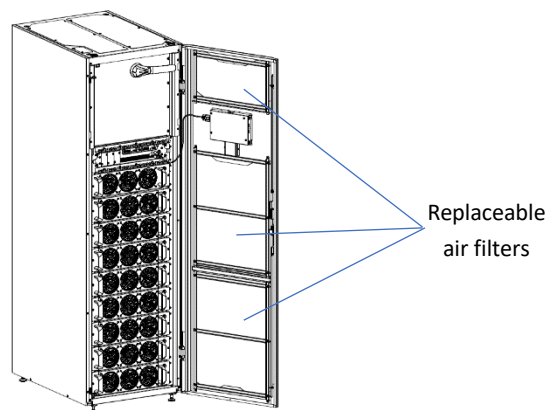

Air filter is available as optional for MP2 300 PCM units.

10.2 REDUNDANT COMMUNICATION BUSES

The internal communication is done by two separate, fully redundant and high-speed buses. In case one of the branches stops working, the other will provide all the information to the system without any delay. Through this new architecture, all data is shared between the modules at faster speed and ensuring the highest availability and the best operational continuity.

10.3 EXTERNAL SYNCHRONISATION

This insulated input can be used to synchronise the Inverter output to a suitable signal from an external source. It is essential when the Multi Power2 is used in combination with Static Switch Transfer Systems.

During installation, it is important to:

- provide in input 230Vac signal (no need for external insulation transformer)
- use double-insulation cable with a cross-sectional area of 1.5mm².

The external synchronisation must be configured via the Configuration Software assigned to authorised personnel. External synchronisation terminals (identified as "EXT SYNC") are closed to power terminal connections to facilitate the installation phase (refer to Installation manual).

10.4 FIRE DETECTION CABLE MP2 500 AND MP2 600

MP2 500 and 600 units have a certified fire detection cable going through all the rear parts of the cabinet. This cable monitors the DC connections of the unit in order to detect the presence of abnormal temperatures, caused for example by an electrical arc, and promptly provides a contact to trigger the battery protections and minimizing the consequences if such a condition persists.

This feature is not available for MP2 300 PCM UPS.

10.5 MONITORING AND CONTROL SOFTWARE

The PowerShield³ software guarantees effective, intuitive UPS management, displaying all the most important information such as input voltage, applied load and battery capacity.

It is also able to perform shutdown operations, send e-mails and network messages automatically when certain events (selected by the user) occur.

10.6 TOP VENTILATION

For the specific request of front-top air ventilation you can choose **MP2 600 PC0 VE** or **MP2 600 PCS VE** units. These UPSs will be provided with dedicated extra fans, installed at the top of the machine. They help manage the airflow generated by the power modules and are properly sized to ensure they operate at full load.

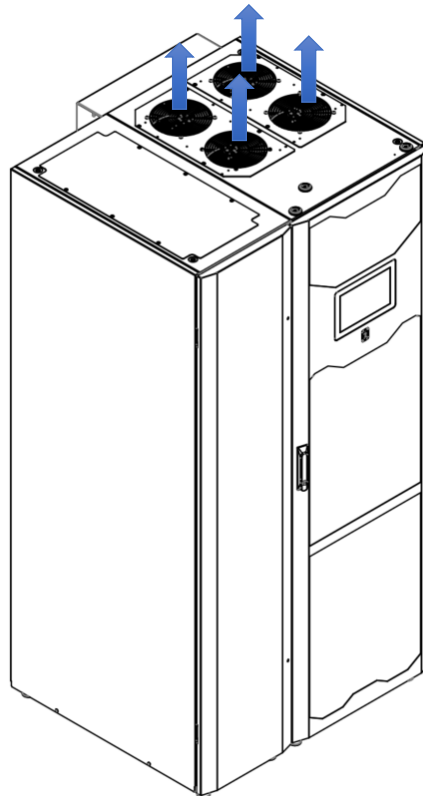

Example of top ventilation configuration MP2 600 PC0 VE unit,
for illustrative purposes only

Fans are carefully selected to reduce their impact on the system; furthermore, they are managed by dedicated logic (hot-swappable) and advanced firmware to minimize the energy consumption and to keep internal components at the optimum working temperature.

The unit with top ventilation is able to work in the following conditions (see table below), even in the case of a failure of one of the fans:

Power Modules	Input Voltage	Ambient Temperature
PM 67 BLUE	400 V (230 V Ph-N)	≤ 40°C
PM 67 BLUE	340 V (195 V Ph-N)	≤ 30°C

Due to the presence of additional fans to extract the air from the roof of the unit, the overall efficiency will be slightly reduced (roughly 0,2%).

For further details about operating conditions, dimensions and performance of the unit, please contact your pre-sales reference.

Top ventilation is available also for MP2 300 PCM with a specific optional kit (please refer to paragraph 11.5)

11. SPECIFIC OPTIONS AND ACCESSORIES MP2 300 PCM

11.1 PARALLEL MP2 300

MP2 300 PCM can be paralleled with other units of the same kind through optional parallel boards, inserted in a dedicated compartment accessible via the roof of the unit.

In order to parallel two or more Power cabinets (cabinet types cannot be mixed), a parallel kit must be ordered per each unit, and each one consists of 2 parallel boards and also n.2 ethernet cables for the connections between the units (10 meters).

This kit is not compatible with Optical Fiber Bus Kit.

For further information about the parallel feature, please refer to the “Parallel kit” manual.

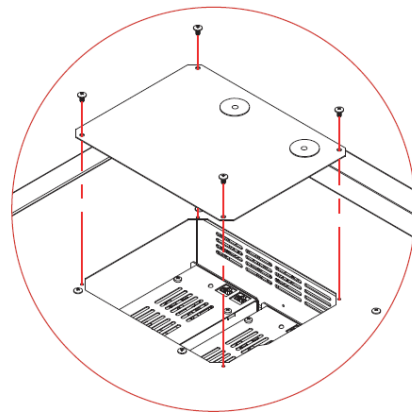
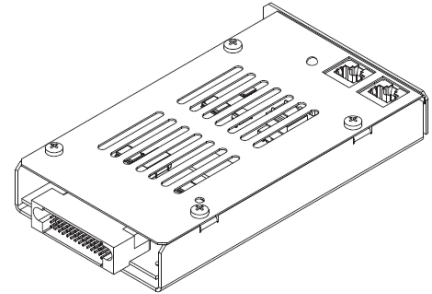

11.2 FRONT DOOR AIR FILTER MP2 300 PCM

A dedicated air filter can be installed in the front door in correspondence of power modules and bypass modules.

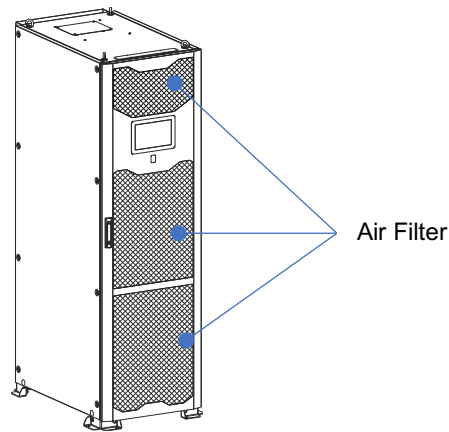

11.3 TOP CABLE ENTRY MP2 300 PCM

MP2 300 PCM cabinet is designed with bottom frontal power connection to facilitate the installation operations.

In case the power cables are coming from the top, a dedicated side cabinet shall be selected to route the cables down to the power bars of the UPS cabinet.

The overall width of the UPS plus the side cabinet is 1000 mm.

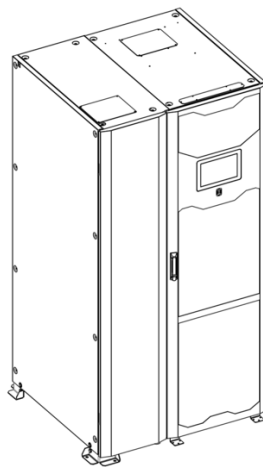

The kit is supplied separately from the UPS and shall be installed on the field (on the left of the UPS) by an authorized technician and following the proper instructions.

For the availability of the kit and other information please refer to your pre-sale contact.

11.4 I/O SIDE CABINET MP2 300 PCM

A dedicated side cabinet with input, bypass, manual bypass and output switch can be connected to the MP2 300 PCM power cabinet, allowing, also, the possibility to connect, without any further option, cables coming from the bottom or top. The overall width of the UPS plus the side cabinet is 1000 mm.

The kit is supplied separately from the UPS and shall be installed on the field (on the left of the UPS) by an authorized technician and following the proper instructions.

For the availability of the kit and other information please refer to your pre-sale contact.

11.5 TOP VENTILATION KIT MP2 300 PCM

For the specific request of front-top air ventilation, MP2 300 PCM units will be provided with dedicated extra axial fans installed in a specific kit positioned in the rear part on the unit.

These fans manage the airflow generated by the power modules and are properly sized to ensure the full load operation.

Fans are carefully selected to reduce their impact on the system; furthermore, they are managed by dedicated logic and advanced firmware to minimize the energy consumption and to keep internal components at the optimum working temperature.

The option is available only if the unit is populated with BLUE modules

The unit with top ventilation is able to work in the following conditions (see table below), even in the case of a failure with any of the fans:

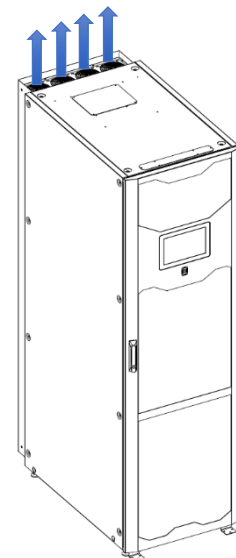

Power Modules	Input Voltage	Ambient Temperature
PM 67 BLUE	400 V (230 V Ph-N)	≤ 40°C
PM 67 BLUE	340 V (195 V Ph-N)	≤ 30°C

Due to the presence of additional fans to extract the air from the roof of the unit, the overall efficiency will be slightly reduced.

For further details about operating conditions, dimensions and performance of the unit, please contact your pre-sales reference.

12. SPECIFIC OPTIONS AND ACCESSORIES MP2 500 / MP2 600

12.1 PARALLEL MP2 500 AND MP2 600

Any Multi Power2 UPS can be paralleled with other units of the same kind through optional parallel boards, inserted into the dedicated slots. In order to parallel two or more Power cabinets (cabinet types cannot be mixed), a parallel kit must be ordered per each unit, and each one consists of 2 parallel boards and also n.2 ethernet cables for the connections between the units (10 meters).

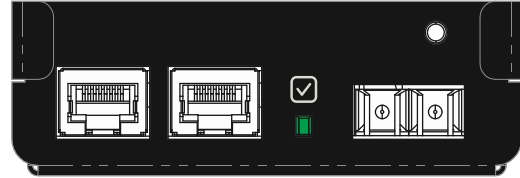

For further information about the parallel feature, please refer to the “Parallel kit” manual.

12.2 OPTICAL FIBER BUS KIT

An Optical Fiber Bus Kit is compatible only with MP2 500 and MP2 600 units.

It can be used to put in parallel 2 or more units instead of the ethernet cables. This solution can be interesting when:

- 1- For instance, the distance between the UPS is more than 20 meters
- 2- There is a strong presence of electrical noise.

The kit is available in two different lengths (25 m or 50 m).

An Optical Fiber Bus Kit shall be ordered per each unit together with the parallel kit (refer to paragraph 12.1)

For further information about the parallel feature, please refer to the “Optical fiber bus Kit” manual.

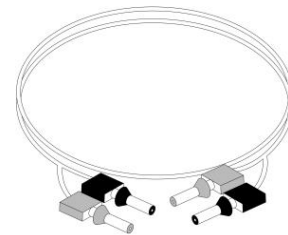

12.3 BOTTOM CABLE ENTRY FOR MP2 500 and MP2 600

MP2 500 PCM and MP2 600 PCO cabinets are designed with top-frontal power connection to facilitate the installation operations.

In case the power cables are coming from the bottom (raised floor for instance) a dedicated side cabinet shall be selected to route the cables up to the power bars of the UPS cabinet.

The side cabinet can be installed on the left or right side of the UPS and the position can be decided on the field.

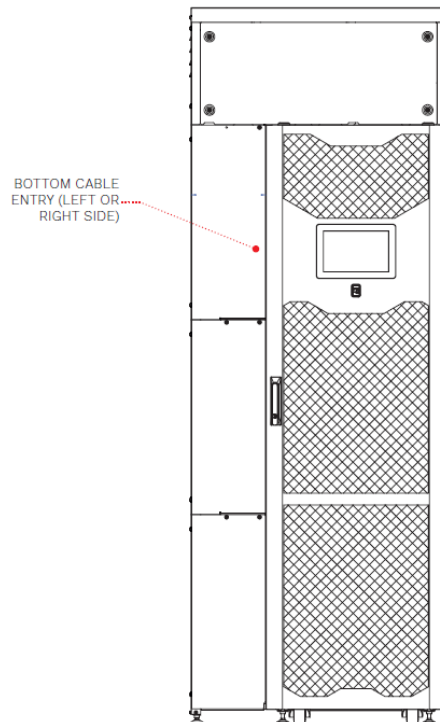

**MP2 500 PCM + side cabinet
for bottom cable entry**

12.4 TN-C KIT for MP2 500 PCM

To deal with different installation requirements, a connection bar between Neutral and Protection Earth is available as an option. For further information contact Riello UPS.

12.5 SEISMIK KIT MP2 500 PCM

With a specific kit, MP2 500 PCM is modified to operate in seismic activity installations according to ICC ES AC156 (2020), SDS = 1.57 g for z/h=1; Ip=1.5. Further details are available in the dedicated documentation.

13. COMMON OPTIONS AND ACCESSORIES MP2 FAMILY

13.1 BATTERY CABINET DESCRIPTION

Battery backup is arranged following the 40 battery blocks without neutral point design and assuming each PM can deliver up to 30 Amps of recharging current.

Multi Power2 - MP2 is compatible with battery cabinets as, for instance, BTC 2000 480V BB V8 3T or BTC 2000 480V BB V9 3T.

For further details about the connections between the UPS and the battery cabinet please refer to the specific manual. Each UPS shall be associated to a battery bank.

If more UPS are connected in parallel (from two to four) the user may decide to have a common battery bank for the parallel system or a dedicated battery bank assigned to each of the units.

During the installation and commissioning the authorized engineer can select and configure the system to operate with a Common or Separated battery in addition to any related settings (refer to the advance configuration manual).

Common Battery Configuration	Separated Battery Configuration	Paired Battery Configuration
<ul style="list-style-type: none"> ➤ Default configuration ➤ Compatible with Conventional Battery cabinets ➤ Applicable from 1 to 4 Cabinets 	<ul style="list-style-type: none"> ➤ Service configuration ➤ Compatible with Conventional Battery cabinets ➤ Applicable from 2 to 4 Cabinets 	<ul style="list-style-type: none"> ➤ Service configuration ➤ Compatible with Conventional Battery cabinets ➤ Applicable with 4 Cabinets, only

The above battery arrangements must be properly configured via the dedicated display menu in accordance with the instructions listed within the Advanced Configuration Manual.

13.1.1 Conventional Battery Cabinets

The battery cabinet should be used to provide suitable power backup time during the failure of the incoming mains power supply. The number of batteries housed within the cabinet varies according to UPS rating and the required backup time. The UPS can monitor the status of the battery switch located within the cabinet via an auxiliary switch contact (if available) connected to programmable input terminal strip.

If one or more Battery Cabinets are installed, the UPS must be configured to update the rated capacity value (Ah of all external battery cabinets). This operation can only be performed via the Configuration Software.

The Riello UPS Battery Cabinet configuration is shown below.

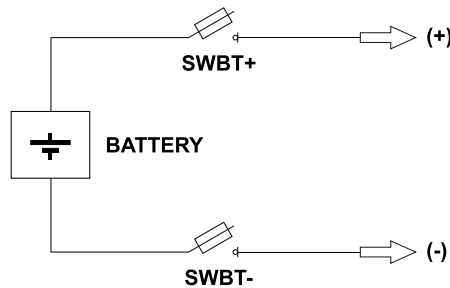

Other solutions may be developed on site, bearing in mind that:

- The structure of the battery enclosure must respect that described above.
- The number of batteries must remain constant: 40 blocks 12 Volt (or wide battery block range, as described in the “DC CIRCUIT” table par. 15) and multiple strings in parallel if required.
- The battery capacity (expressed in Ah) must fall within the range of 4 and 20 times the available recharging current (see the “Technical Specifications Table”).

MODELS BATTERY CABINETS	BTC 2000 480V BB V8 3T	BTC 2000 480V BB V9 3T
-------------------------------	------------------------	------------------------

DIMENSIONS
(mm)
W x D x H

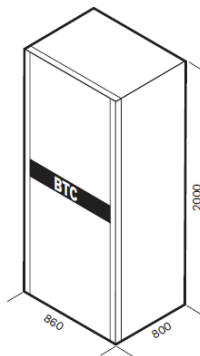

1445 kg (235 empty)	1590 kg (235 empty)
------------------------	------------------------

Above battery cabinets are suitable for UPS up to 500 kW. For bigger power a dedicated solution can be selected by our pre-sales team.

The battery cabinets can be connected in parallel to achieve the required autonomy; for 2 or more cabinets in parallel, it is advisable to add a battery switch cabinet.

Here below a possible example considering MP2 500 UPS:

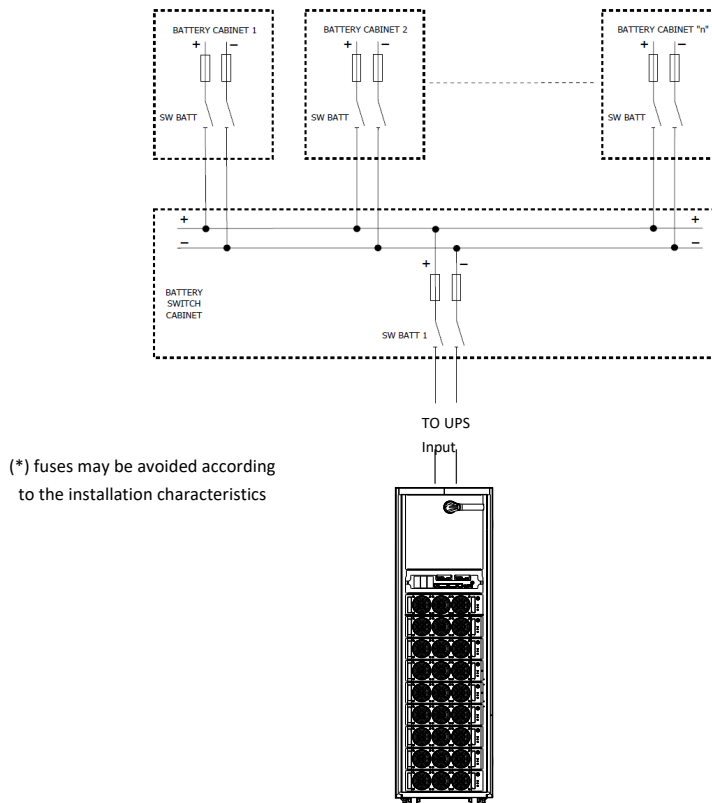

**Example of DC connection
MP2 500 PCM + battery switch**

For further details on Battery Cabinet installation refer to the UPS installation manual.

13.2 EXTERNAL BATTERY TEMPERATURE SENSOR

The UPS has a specific connection point for measuring the temperature inside an external Battery Cabinet and indicating the temperature on the UPS display.

The specific kit supplied by the manufacturer includes a bipolar double insulated cable measuring 10 meters. The use of a bipolar cable without insulation exposes the UPS and the user to risks resulting from a lack of insulation as the reading refers directly to the UPS neutral earthing.

Once installed, it is necessary to enable the temperature display information and activate the voltage compensation. Both operations can be performed using the Configuration Software (by service personnel).

The kit enables the connection of a temperature probe for a Battery Cabinet placed adjacent to the UPS or 10 meters away. If it is not enough it is possible to extend it up to 25 meters (sensor cable length shall be arranged by the user).

For further details refer to dedicated option installation manual.

13.3 SEPARATE INPUT LINES (DI)

Multi Power2 units are supplied with single inputs for the rectifier and bypass stages.

Without any optional kit, the unit can be configured as dual input just removing the jumper between the inputs.

13.4 OPTIONAL TRANSFORMERS

A transformer can be installed outside the UPS (depending on the requirements and the type of electrical set up described below). Please refer to your pre-sales contact for further information and details.

All Multi Power2 units can work with external transformers.

Note: the presence of the transformer will modify the neutral arrangements of the installation. The eventual installation of a "remote maintenance bypass" to isolate the UPS, in case of breakdown / maintenance has to be located after the transformer (if the same is installed in the UPS input) or upstream of the transformer (if the same is installed in the UPS output).

The following drawings provide a general overview of the possible installation scenarios.

Every configuration should be carefully evaluated according with the real installation environment.

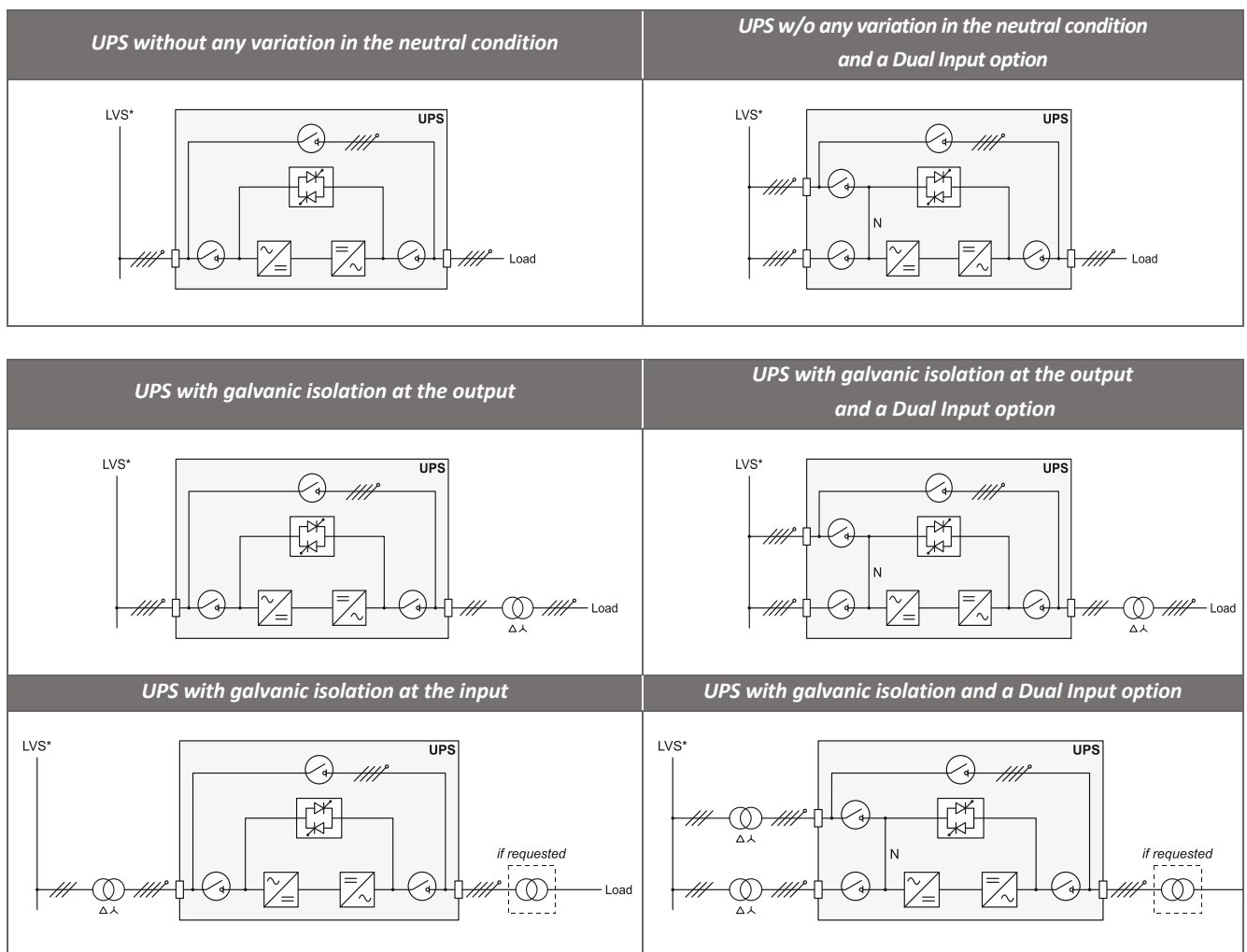

* LVS: low voltage source

13.4.1 Separated Lines Upstream (DI)

If the Dual Input option is present and the bypass is supplied from a separate low voltage source, protective devices must be present on both the main input supply and the bypass supply (refer to UPS installation manual).

Neutral of the input line and that of the bypass are joined inside the equipment, therefore they will refer to the same potential. If the two mains supplies are different, it is necessary to use an isolation transformer on one of the inputs.

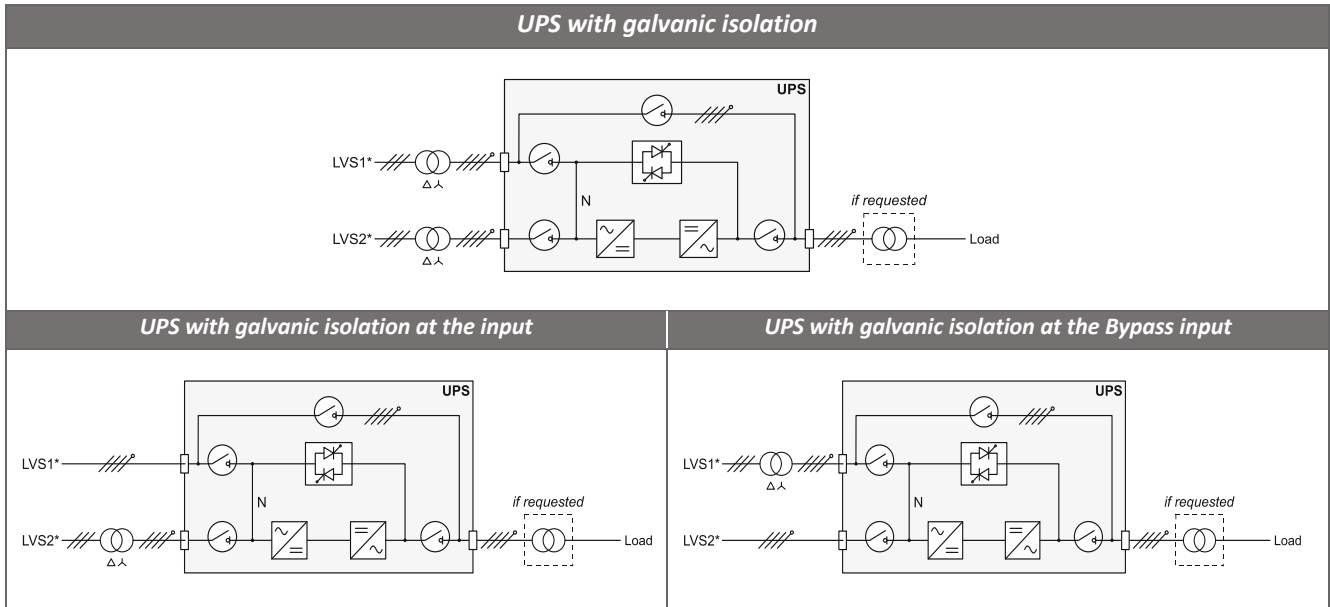

* LVS1: low voltage source 1; LVS2: low voltage source 2.

13.5 COMMUNICATION CARDS

The connectivity panel provide extra two panel expansion slots for accessory communication cards that make it possible to communicate with the UPS using different communication protocols.

MultiCom 302: a Modbus/Jbus protocol converter through an RS232 or RS485 output for monitoring the UPS, for example, from a BMS (Building Management System). It also provides a second independent RS232 serial line that can be used by other devices such as a NetMan or PC.

MultiCom 411: it is an external accessory with which you can connect a UPS to a Profibus DP network. With this device management and monitoring of the UPS can be integrated in a control system based on one of the field buses most widely used in industry for communication between control/automation systems and distributed I/O.

MultiCom 421: this board connects the UPS to a PROFINET Network. In industrial environments, the Gateway integrates the UPS management and monitoring into a control system. The Gateway uses the PROFINET control system – one of the most popular used for communicating between devices such as automation control systems and distributed I/O hardware.

MultiCom 372: MultiCom 372 provides a UPS with an additional RS232 serial interface port. The card has Emergency Power Off (EPO) and Remote Shutdown (RSD) inputs with terminal connections.

MultiCom 392: Multi Power range includes a specific relay card (MultiCom 392) having 8 programmable relay alarms (25 Volt, 1 Amp) and 3 programmable inputs.

Input/output configurations might be adjusted through the advanced configuration software available for authorised engineers (Service SW).

In order to carry out card installation and configuration refer to the dedicated manual.

13.6 ENERGYMANAGER FOR LI-ION BATTERIES

This optional card must be used when the UPS is connected to the BMS (Battery Monitoring System) of a Li-Ion battery system which has been approved by Riello UPS, please refer to the specific user manual of this card for the full list.

The EnergyManager includes two ports:

- Ethernet port 10/100 Mbps (RJ45 connector)
- RS485 serial port (RJ12 connector)

The two ports can be utilised depending on the battery type to communicate with the BMS of the battery cabinet, as described within the specific user manual.

13.7 COLD START

The Cold Start is a function that allows the system to start from the batteries, with the mains disconnected. This kit can be installed on the field and it's available for MP2 500 PCM and all the MP2 600 versions.

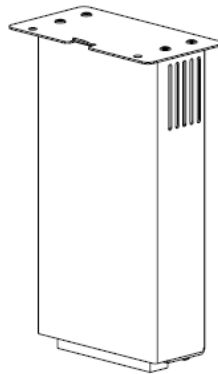



Cold Start Unit

14. ENVIRONMENTAL DATA MP2





	Power Cabinet MP2 300 PCM	Power Cabinet MP2 500 PCM	Power Cabinet MP2 600 PCO	Power Cabinet MP2 600 PCO VE	Power Cabinet MP2 600 PCS VE
Operating temperature (continuous)	0-40° C				
Recommended working temperature for optimum battery performance	20 to 25° C				
Storage temperature	-25 up to +60 °C (UPS)				
Relative humidity range	5-95% non-condensing				
Maximum Operating Altitude (according with IEC/EN 62040-3)	Full power up to 1000 m a.s.l. (power derating of 0.5% for each 100 m between 1000 and 3000 m)				

15. TECHNICAL DATA
Power modules:

	PM 67 kW BLUE	PM 67 kW*
Main features		
Technology	SiC	IGBT
Power	67 kW	67 kW
Efficiency in double conversion	Up to 98.2%	Up to 96.5%
Weight	37 kg	
Dimensions WxDxH	450 x 630 x 135 (3U) mm	
Ventilation	Forced	
Cabinet IP rating	IP20 finger proof (either with cabinet doors open or closed)	
Electrical connection	Rear plug in connectors	
Coating treatment	Available as option	
Colour	RAL 9005 + Blue band	RAL 9005 + Grey band

* Only suitable for MP2 500 PCM and MP2 600 PCO

UPS overview:

	MP2 300 PCM	MP2 500 PCM	MP2 600 PC0	MP2 600 PC0 VE	MP2 600 PCS VE
Main features					
Nominal Power ⁽¹⁾	300 kW	500 kW	600 kW	600 kW	600 kW
Bypass Power	300 kW	500 kW	600 kW	600 kW	600 kW
Module slots available	5	8	9		
Number of power modules to reach nominal power	5x MP2 67 PM or 5x MP2 67 PM BLUE	8x MP2 67 PM or 8x MP2 67 PM BLUE	9x MP2 67 PM or 9x MP2 67 PM BLUE	9x MP2 67 PM BLUE	9x MP2 67 PM BLUE
Parallelable up to	Up to 4 units				
Max power expandability	1200 kW	2000 kW	2400 kW		
Dimensions & weight [WxDxH] ⁽²⁾	600x940x1995 429 kg	600x870x1997 640 kg	600x870x1997 680 kg	1000x990x2000 800 kg	1200x990x2000 930 kg
Moving UPS cabinet types	Castors (cabinets shipped without PM)				
Ventilation	Forced				
Air Inlet	Front				
Air outlet	Rear			Top	
Cabinet IP rating	IP20				
Cable input	Bottom (top with optional)	Top (bottom with optional)		Top or bottom	
Rated Conditional Short Circuit Current "Icc"	Up to 50 kA (with external fuses)	Up to 65 kA	Up to 100 kA		Up to 65 kA
Icc @ 400V without the use of - SWMB	Up to 100 kA	Up to 100 kA	N.A		Up to 100 kA
Standards	Safety IEC EN 62040-1, EMC: IEC EN 62040-2				
Colour	RAL 9005				

⁽¹⁾ Power rating depends on the selected number of power modules.

⁽²⁾ Weight including power module to reach nominal full power

16. ELECTRICAL DATA

Input electric data are calculated considering the worst case (IGBT power module) and single unit.

INPUT	MP2 300 PCM	MP2 500 PCM	MP2 600 PC0	MP2 600 PC0 VE	MP2 600 PCS VE
Nominal voltage	380-400-415 Vac Three-Phase plus neutral				
Voltage tolerance	340 to 480 V at 100% of the load 240 to 480 V at 50% of the load				
Maximum load applicable with ONE input phase missing ⁽³⁾	66%				
Maximum load applicable with TWO input phases missing ⁽³⁾	33%				
Nominal frequency	50 or 60 Hz				
Input frequency tolerance	40 to 72 Hz				
Maximum Input Current [A] ⁽⁴⁾	573	934	1083		
Total Harmonic distortion (THDi) with full load and source THDv <1%	<3%				
Power factor	> 0.99				
Rectifier progressive start-up (Power Walk-in duration)	Configurable from 1 to 120 s in step of 1 s (standard disable)				
Adjustable delay for the rectifier start up (Power Walk-in start delay)	Configurable from 1 to 120 s in step of 1 s (3 seconds by default)				

⁽³⁾ From system OFF it will only start up if phases L1 and L2 are present.

⁽⁴⁾ The maximum input current is stated for the worst case: Input voltage at 364 V, nominal output power, single unit equipped with 8 (500 kW) or 9 (600 kW) IGBT modules, battery in recharge and 40 batteries configuration.

DC CIRCUIT	MP2 300 PCM	MP2 500 PCM	MP2 600 PC0	MP2 600 PC0 VE	MP2 600 PCS VE
Battery arrangement	Separate or common batteries at UPS level				
Number of poles	2 wires (+/-)				
Number of battery cells - VRLA	240 (other configurations available upon request)				
Battery block range per string – VRLA	30 to 46 40 - 46@ full nominal power 38 @ 95% nominal power 36 @ 90% nominal power 34 @ 85% nominal power 32 @ 80% nominal power 30 @ 75% nominal power				
Float voltage (2.27 V/el. Adjustable) - VRLA	545 V ⁽⁵⁾				
Boost voltage (2.38 V/el. Adjustable) - VRLA	571 V ⁽⁵⁾				
End of discharge voltage – load dependent (1.6 V/el. Adjustable) – VRLA	384 V ⁽⁵⁾				
Compatible with	VRLA, Ni-Cd, Li-Ion, Supercaps ⁽⁶⁾				
Battery recharging current ⁽⁷⁾	30 A per each power module installed up to 66% load 20 A per each power module installed @ 83% load 10 A per each power module installed @ 100% load				
Maximum current drawn from batteries with UPS working at nominal power	785 A	1309 A		1571 A	
Voltage compensation (if temperature sensor active)	18 mv/°C (12 Volt block)				

⁽⁵⁾ This value refers to 40 blocks; refer to service documents for customised setting according with a different number of batteries.

⁽⁶⁾ Only specific models are compatible with supercaps, please refer to your sales contact.

⁽⁷⁾ The currents refer to input voltages ≥ 364 Volt.

INVERTER	MP2 300 PCM	MP2 500 PCM	MP2 600 PCO	MP2 600 PCO VE	MP2 600 PCS VE
Max system nominal power	300 kVA	500 kVA	600 kVA		
Max system nominal active power	300 kW	500 kW	600 kW		
Power range	67-300 kW	67-500 kW	67-600 kW		
Power module size	67 kW (PM 67 BLUE or PM 67)			67 kW (PM 67 BLUE)	
Nominal voltage	380/400/415 Vac Three-Phase plus neutral				
Downgrading for output voltage different set-up	220 Volt [Ph-N]: -4% 208 Volt [Ph-N]: -10% 200 Volt [Ph-N]: -13%				
Inverter current @400 V and rated power of the unit	435 A	725 A	870 A		
Nominal frequency	50 or 60 Hz				
Static stability	± 1 %				
Dynamic stability	Compliant with EN 62040-3 class performance 1				
Voltage distortion (EN 62040-3)	≤ 1.5% with linear resistive load				
Inverter frequency stability without bypass supply synchronisation	0.01%				
Rate of Frequency variation	1 Hz/s (adjustable from 0.5 to 2)				
Inverter Overload (@ 25°C – 400 V)	>103% - ≤125% 10 min >125% - ≤150% 1 min >150% 0.5 s				
Short circuit current (Ph-N)	2.5 x In for 100 ms + 1.5 x In for 400 ms				
Efficiency on battery operation PM 67 BLUE	97.4% with BLUE PM (load rate > 25% and ≤ 50%) 97.2% with BLUE PM (load rate > 50% and ≤ 80%) 96.7% with BLUE PM (load rate > 80%)			97.2% with BLUE PM (load rate > 25% and ≤ 50%) 97.0% with BLUE PM (load rate > 50% and ≤ 80%) 96.4% with BLUE PM (load rate > 80%)	
Efficiency on battery operation – PM 67	95.5% (Load rate >50% - ≤ 80%) 95.3% (Load rate >25% - <50% and >80% - <100%)			-	









BYPASS	MP2 300 PCM	MP2 500 PCM	MP2 600 PCO	MP2 600 PCO VE	MP2 600 PCS VE
Nominal power	300 kW	500 kW	600 kW		
Nominal voltage	380/400/415 Vac Three-Phase plus neutral				
Output nominal current @400 V	435 A	725 A	870 A		
Bypass voltage range	From 180 V (Adjustable 180 V-200 V) to 264 V (adjustable 250 V-264 V)				
Nominal frequency	50 or 60 Hz				
Bypass input frequency range	±5% (adjustable from 0.25 to 10%)				
Transfer time bypass to Inverter (UPS in "ECO mode")	2 ms typical				
I ² t Thyristor value	451 000 A ² s	1 805 000 A ² s	7 220 000 A ² s		
I ² t internal fuse pre-arc value	25 000 A ² s	245 000 A ² s	365 000 A ² s		
Max current in short circuit for 20 ms	2.5 kA	8 kA	10 kA		
Overload capability on bypass line (@ 30 °C, 400 V)			1 hour @ 110% Pn 10 min @ 125% Pn 1 min @ 150% Pn		

Efficiency AC/AC @ 400V	MP2 67 PM BLUE (67kW)	MP2 67 PM (67 kW)
AC/AC Efficiency @ Full load	97.2%	95.8%
AC/AC Efficiency @ 75%	97.7%	96.2%
AC/AC Efficiency @ 50%	98.1%	96.5%
AC/AC Efficiency @ 25%	98.1%	96.2%
Power dissipated with resistive full load (pf=1) @ 400 V*	1.93 kW 1657 kcal/h 6585 B.T.U/h	2.94 kW 2519 kcal/h 9998 B.T.U/h

*3.97 B.T.U = 1 kcal

ECO Mode efficiency	
Efficiency: UPS System ECO Mode at 50% load rate	Up to 99.4%
Efficiency: UPS System ECO Mode at 100% load rate	Up to 99.3%

17. SUMMARY TABLE

Summary	MP2 300 PCM	MP2 500 PCM	MP2 600 PC0	MP2 600 PC0 VE	MP2 600 PCS VE	MP2 600 CT4 VE
Max N° of PM	5 x 67 kW PM/PM BLUE	8 x 67 kW PM/PM BLUE	9 x 67 kW PM/PM BLUE	9 x 67kW PM BLUE		
Switches	SWMB		N/A		SWIN, SWBY, SWOUT, SWMB	
Standard backfeed protection	Std					
Backfeed Protection Device	N/A ^(*)	N/A			Std	
Front To Rear Ventilation	Std			N/A		
Front To Top Ventilation (Ve)		N/A		Std		
Bottom Cable Entry	Std		Std			
Top Cable Entry		Std				
Single Input	Std					
Dual Input	Std ⁽¹⁾					
Air Filter		Std				
Cold Start						
Coating Treatment						
Castors	Std					
Parallel (Lan/Optical Fiber) ⁽⁴⁾	 ⁽²⁾					
External Sync	Std					
Connectivity Panel	5 In, 4 Out 2 Com. Slots			10 In, 8 Out 2 Com. Slots		
Network Card	Std ⁽³⁾			Std		
Pressure Sensor	N/A			Std		
Battery Temperature Sensor						
Fire Detection Cable	Std					



Optional, onsite kit installation



Optional, factory installation

^(*) OPT from END 2025

⁽¹⁾ Just removing the connections between the two inputs

⁽²⁾ Only Lan cables

⁽³⁾ Embedded within Connectivity Panel

⁽⁴⁾ 1 kit per each unit



www.riello-ups.com