

Formula 65 LED LG230 8W

230Vac - 50/60Hz - 216Vdc Ta: -20:40°C



Beghelli

BEGHELLI S.p.A. - Via Mozzeghine 13/15 - 40053 Loc. Monteveglio - Valsamoggia (BO) - Tel. +39 051 9660411 - Fax +39 051 9660444 - N° Verde 800 626626

www.beghelli.com



Per approfondimenti e aggiornamenti inquadra il codice QR sul prodotto
For further information and updates, scan the QR code on the product

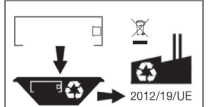

334.901.853 B

A

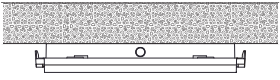

+ cod. 19048

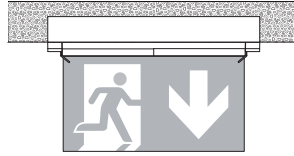

+ cod. 19048
+ cod. 19042 - 19043

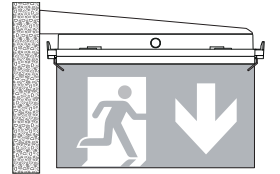

+ cod. 19045
+ cod. 19042 - 19043

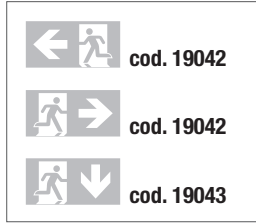
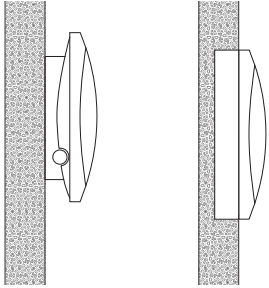

+ cod. 19048

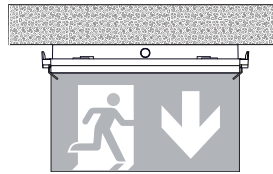

+ cod. 19042 - 19043

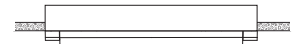

+ cod. 19049

B

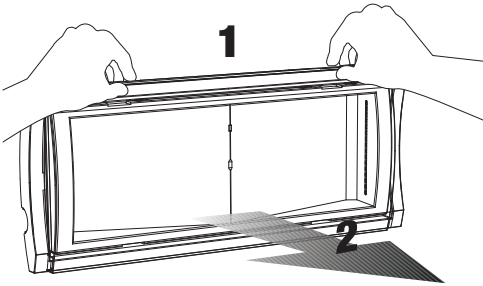

C

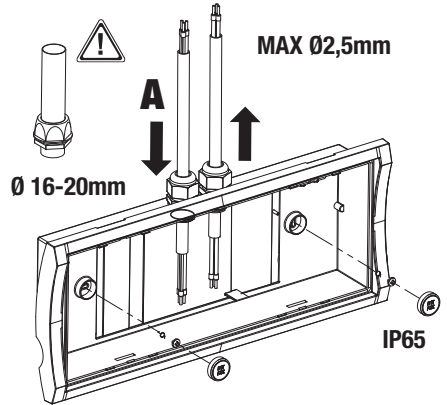

D

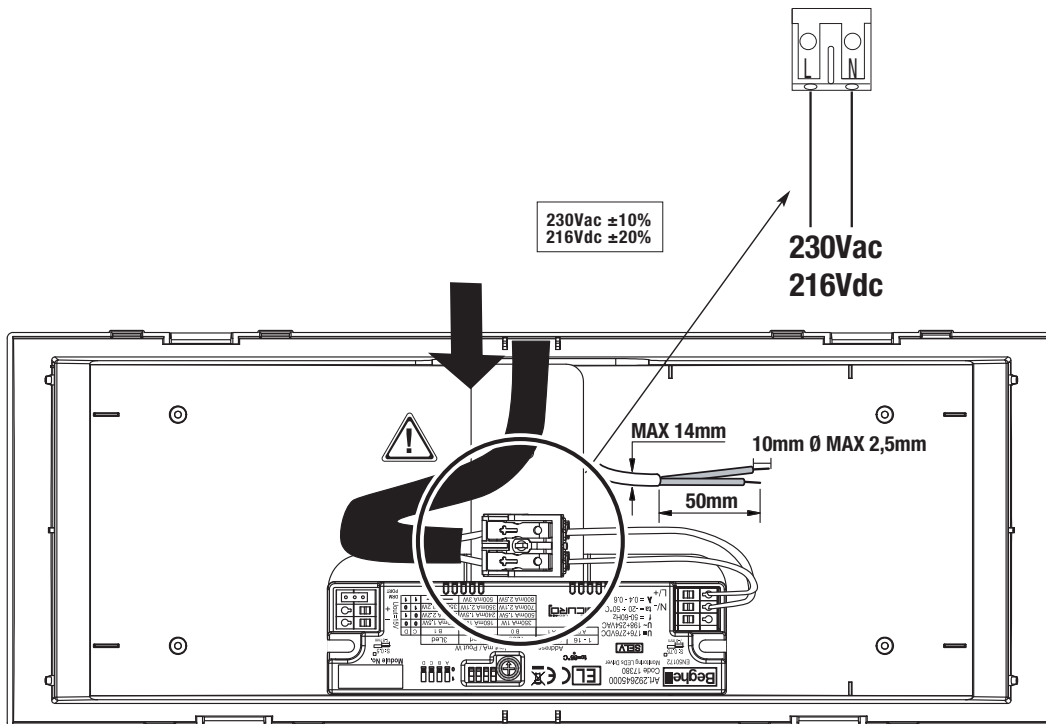

E1

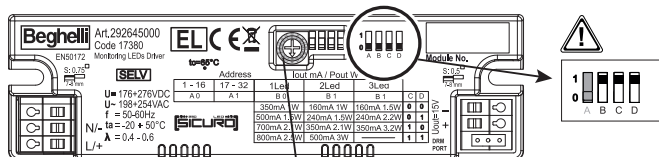

ADDRESS

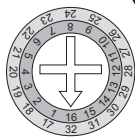

1-16

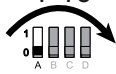

17-32



E2

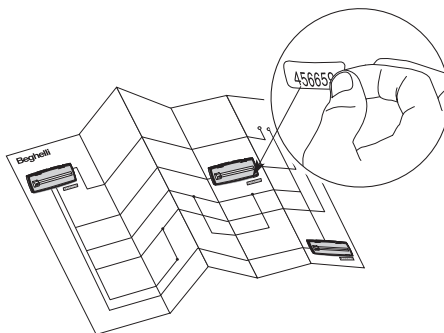
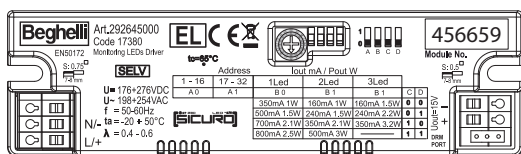

	230Vac - 50Hz	216Vdc
	VA	W
31124	8,5	4,1

NOTLEUCHTE FÜR RETTUNGSZEICHEN UND FLUCHTWEGE

Die Leuchte ermöglicht ein zentralisiertes Schalten sowie Diagnosefunktionen.

Die Leuchte ist mit einem Drehschalter zur manuellen Adressierung ausgestattet (Abb. E1).

Alternativ kann die Adressierung automatisch über die Zentrale durch Einlesung der ID erfolgen (Abb. E2).

ANSCHLUSSSCHEMA

Netzanschlüsse (L/+; N/-) und Polung berücksichtigen (Abb. D).

KODIERUNG

Adressen: von 1 bis 16 – (Abb. E1).

Adressen: von 17 bis 32 – (Abb. E1).

abweichende Verwendung wird als nicht zweckentsprechend und somit als gefährlich angesehen.

- Die LED-Quelle ist nicht auswechselbar. Für eventuelle Reparaturen autorisiertes Service-Center kontaktieren, um Originalersatzteile anzufordern. Das Nichteinhalten der oben genannten Bestimmungen

kann die Sicherheit der Leuchte gefährden.

EMERGENCY LUMINAIRE FOR EXIT SIGNS AND ESCAPE ROUTES

The luminaire allows a centralised switching as well as diagnostic functions.

The luminaire is equipped with a rotary switch for manual addressing (Fig. E1). Alternatively the addressing

can be done automatically over the central by read-in of the ID (Fig. E2).

WIRING DIAGRAM

Consider mains connections (L/+; N/-) and polarity (Fig. D).

CODING

Addresses: from 1 to 16 – (Fig. E1).

Addresses: from 17 to 32 – (Fig. E1).

Any other use is considered improper and therefore as dangerous.

- LED source is not replaceable. For any repairs possibly required contact an authorised service center to require original spare parts. The non-compliance of the abovementioned regulations may harm the safety of the luminaire.

APPARECCHI PER SEGNALETICA E ILLUMINAZIONE DI EMERGENZA

L'apparecchio consente di centralizzare l'accensione e lo spegnimento integrando funzioni di diagnosi. L'apparecchio è dotato di un selettore rotativo per l'indirizzamento (Fig. E1).

In alternativa l'acquisizione in cen-

trale può essere effettuata automaticamente tramite il riconoscimento dell'ID (Fig. E2).

SCHEMI DI COLLEGAMENTO

Collegamenti rete (L/+; N/-) rispettare la polarità (Fig. D).

CODIFICA

Indirizzi: da 1 a 16: (Fig. E1).

Indirizzi: da 17 a 32: (Fig. E1).

Ogni altro uso è da considerarsi improprio e pericoloso.

- La sorgente LED è di tipo non sostituibile. Per eventuali riparazioni rivolgersi ad un centro di assistenza tecnica autorizzato e richiedere l'utilizzo di ricambi originali. Il mancato rispetto di quanto sopra può compromettere la sicurezza dell'apparecchio.

- Per le modalità di intervento in garanzia contattare il Numero Verde 800 626626 o il Rivenditore Autorizzato.

AVVERTENZE - GARANZIA

- Questo apparecchio dovrà essere destinato solo all'uso per il quale è stato costruito.

NOUZOVÁ SVĚTLIDLA PRO NOUZOVÉ ZNAČENÍ A ÚNIKOVÉ CESTY

Svítidlo umožňuje centrální spínání i diagnostické funkce. Svítidlo je vybaveno spínačem pro manuální adresování (Obr. E1).

Případně může být adresování provedeno automaticky přes centrální jednotku a to načtením ID (Obr. E2).

SCHEMA ZAPOJENÍ

S ohledem na síťové připojení (L/+; N/-) a polaritu (Obr. D).

KÓDOVÁNÍ

Adresy: od 1 do 16 – (Obr. E1).

Adresy: od 17 do 32 – (Obr. E1).

UPOZORNĚNÍ - ZÁRUKA

- Toto svítidlo může být použito pouze k účelu, pro nějž bylo vyrobeno. Jakékoliv jiné použití bude považováno za nevhodné a tím také nebezpečné.

- LED zdroj není vyměnitelný. Pro případné opravy se obraťte na autorizované servisní středisko, které

používá pouze originální náhradní díly. Nerespektování výše uvedených podmínek může ohrozit bezpečnost svítidla.