

Modular UPS System

MP2 NP - 67 kW up to 300 kW

Installation manual

SUMMARY

GLOSSARY OF ACRONYMS	5
IMPORTANT SAFETY INFORMATION	6
POWER CABINET MP2 300 PCM	8
PRELIMINARY INFORMATION FOR INSTALLATION	8
INSTALLATION ENVIRONMENT	8
ELECTROMAGNETIC COMPATIBILITY	9
OPERATIVE PROCEDURES	9
OVERVOLTAGE PROTECTION	9
POSITIONING INFORMATION	10
UPS PARTS AND MODULES	12
POWER CONNECTION INFORMATION	13
SYSTEM PROTECTIONS INFORMATION	14
INPUT LINE PROTECTION	14
SHORT CIRCUIT PROTECTION	14
SHORT-CIRCUIT WITHSTANDING	14
BACKFEED PROTECTION	14
RCD BREAKER (RESIDUAL CURRENT DEVICE)	15
REMOVING DOOR	16
POWER CONNECTION DETAIL	17
BOTTOM CABLE ENTRY	19
JUMPER REMOVAL FOR DUAL INPUT	20
EXTERNAL SYNC	20
POWER CONNECTION POSITIONS	21
EARTH CONNECTION POSITION	22
REPLACING DOOR AIR FILTER [OPTIONAL]	23
VERTICAL EXHAUST [OPTIONAL]	24
INSERTION/EXTRACTION MODULES AND UNITS PROCEDURE	25
POWER MODULE (PM)	25
INSERTION	26
EXTRACTION	26
BYPASS MODULE 500AMP (BM)	27
EXTRACTION	28
INSERTION	29
MAIN COMMUNICATION UNIT (MCU)	31
CONNECTIVITY PANEL (CP)	32
SYSTEM MONITORING UNIT (SMU)	32
PARALLEL INTERFACE BOARD (PIB) [OPTIONAL]	32
SMU (SYSTEM MONITORING UNIT)	33
EXTRACTION	33
INSERTION	33

COMMUNICATION INTERFACE - SMU	34
R.E.P.O.	34
PROGRAMMABLE IN – OUT SIGNALS	34
AUXILIARY SIGNALS	35
USB AND SERIAL (SERVICE PORT)	36
COMMUNICATION SLOTS	36
DISPLAY PORT	36
SYSTEM INSTALLATION	37
CABLES LENGTH INFORMATION	37
SYSTEM PROTECTION INFORMATION	38
PARALLEL UPSs POWER CONNECTIONS (COMMON/SEPARATED/PAIR)	39
PARALLEL UPSs SIGNAL CONNECTIONS (REPO/EXTTEMP/EXTSYNC)	40
TYPICAL AUXILIARY SWITCH INSTALLATION	41
BATTERY CABINET POWER CONNECTIONS	42

GLOSSARY OF ACRONYMS

ACRONYM	ITEM	DESCRIPTION
MP2	Multi Power 2	<i>UPS Modular family name – 2nd generation</i>
BTC	Battery Cabinet	<i>Any battery cabinet</i>
MP2 300 PCM	Power cabinet 300 kW MP2	<i>Power Cabinet with 5 slots to place 5 x MP2 67 PM + 500A BM + SMU + MCU</i>
PM	Power Module	<i>Power Module unit</i>
MP2 67 PM	Power Module 67 kW MP2 3U	<i>67 kW 3U Power Module unit IGBT components - 400V IN/OUT</i>
MP2 67 PM BLUE	Power Module 67 kW MP2 3U – BLUE	<i>67 kW 3U Power Module unit SIC components - 400V IN/OUT</i>
BM	Bypass Module	<i>Solid state transfer device module (Acronym used to indicate any BM)</i>
500AMP BM	Bypass Module 500A	<i>500A Solid state transfer device module</i>
SMU	System Monitoring Unit	<i>Item for: bypass control, system Control, switches status, ext. I/O and EPO control, communication ports, display port, slots</i>
MCU	Main Communication Unit	<i>Display - Synoptic</i>
SLOT	Slots	<i>Slot to accommodate communication cards</i>
PIB	Parallel Interface board	<i>Parallel interface board</i>
SA	Service Access Port	<i>Port interface to connect service maintenance tools</i>
SWMB	Switch Manual Bypass	<i>Manual bypass switch</i>
B+	-	<i>Positive battery voltage/current/temp.</i>
B-	-	<i>Negative battery voltage/current/temp.</i>

IMPORTANT SAFETY INFORMATION

ALL OPERATIONS DESCRIBED IN THIS SECTION MUST BE PERFORMED BY QUALIFIED AND TRAINED PERSONNEL ONLY.



READ "SAFETY MANUAL" BEFORE STARTING THE MODULAR UPS POWER CABINET INSTALLATION

Our Company assumes no liability for damages caused by incorrect connections or operations not contained in this manual.

The following operations have to be performed with the UPS disconnected from the power mains, off and with all equipment switches open.

Before making the connection, open all switches and verify that the UPS is completely isolated from power sources: battery and AC power line. In particular, check that:

- the UPS input line is completely disconnected*
- the UPS bypass line is completely disconnected*
- the external UPS battery line switch/fuses are open*
- all UPS switches are in the open position*
- check with a multimeter that there are no dangerous voltages*



SAVE THIS INSTRUCTIONS: *This manual contains important instruction to properly install the UPS unit. Read safety manual before starting UPS installation.*



High leakage current. *This product can cause a d.c. current in the PE conductor.*

The first connection to be made is the protective conductor (earth wire), this must be connected to the bar marked as PE. The UPS must operate while connected to the earthing system.



The input Neutral must always be connected.



WARNING: *a 4-wire three-phase distribution system is required.*

The UPS must be connected to a power supply source providing 3-phase + neutral + PE (protective earth) of a TT, TN or IT type. The phase rotation must be correct.

In the IT system a 4-pole thermal-magnetic circuit breaker is mandatory.



Install the line protection devices (fuse, magneto-thermal and differential switches) as indicated in the chapters "POWER CONNECTION INFORMATION" and "SYSTEM PROTECTIONS INFORMATION"



Read the User Manual before using this product.

Read the Battery Cabinet manual before connecting the batteries.



Check that the total battery voltage meets the requirements of the UPS (refer to the Battery Cabinet nameplate).



ATTENTION: *the maximum length of the connection cables to the battery is 20 meters. Furthermore, the two battery cables (+, -) must be placed close to each other in order to avoid loops.*



ATTENTION: *After the installation operation is complete, refit the cabinet protection panels using the appropriate screws.*



ATTENTION: *If "AUTO-RESTART OPTION" is set, when the mains supply returns the system will automatically switch ON and the load will be powered.*



WARNING: *this uninterruptible power supply (UPS) conforms to all binding safety and electromagnetic compatibility regulations applicable to this type of product. Compliance with these regulations has been certified by accredited third-party bodies.*

In addition to that prescribed in the directives, during the design phase our company made every effort to assess and eliminate or minimize all risks deriving both from correct use and possible reasonably foreseeable incorrect operations. Civil society and the institutions place special emphasis on protecting certain categories of people (pregnant women, minors, people with cognitive and/or motor disabilities, people wearing pacemakers).

That being said, despite the fact that the UPS is a product reserved for professional and non-domestic use, the above-mentioned people must not access the areas where the UPS is installed.

Moreover, the UPS must be installed in an area that cannot be accessed by domestic animals or where the latter cannot station in.



ATTENTION: *the SWMB disconnection switch installed on the Modular UPS Cabinet is not a maintenance bypass switch, therefore, there is dangerous voltage within the Cabinet, even if this disconnection switch is closed.*



BATTERY ROOM VENTILATION

The room in where the battery is located must have enough ventilation to ensure the concentration of hydrogen produced is within safe limits.

The room should preferably be ventilated naturally; if it cannot be, forced ventilation may be employed.



PERSONAL PROTECTIVE EQUIPMENT (PPE)

No maintenance operations must be carried out on the device without wearing the Personal Protective Equipment (PPE) described below.

Personnel involved in the installation or maintenance of the equipment must not wear clothes with wide sleeves or laces, belts, bracelets or other items that may be dangerous, especially if they are metallic.

Long hairs must be tied in such a way as to ensure that they are not a hazard.

The following symbols show the protective equipment that should be worn. The various items of PPE must be selected and sized according to the nature of the hazard (particularly electrical) posed by the equipment.



Protective footwear
Use: always



Protective eyewear
Use: always



Protective clothing
Use: always



Helmet
Use: when overhead structures are present.



Work gloves
Use: always



Dust mask
Use: Always



Some images contained in this document are for information purposes only and may not faithfully demonstrate the parts of the product they represent.

POWER CABINET MP2 300 PCM

PRELIMINARY INFORMATION FOR INSTALLATION

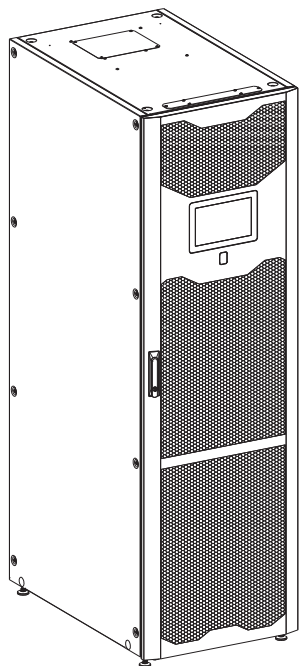

INSTALLATION ENVIRONMENT

When choosing the site in which to install the UPS and the Battery Cabinet, the following points should be taken into consideration:

- Avoid dusty environments.
- Avoid rooms with conductive, inflammable and corrosive items.
- Check that the floor is level and capable of withstanding the weight of the UPS and the Battery Cabinet.
- Avoid cramped environments that could impede the normal maintenance activities.
- The relative humidity should not exceed 95%, non-condensing.
- Avoid installing the equipment in places exposed to the direct sunlight or hot air.
- This equipment is intended for use in a controlled environment; hence the temperature must be regulated within a range between 0 and 40°C.



The UPS may be operated within an ambient temperature of between 0 to 40°C. The recommended working temperature for the UPS and batteries is between 20 to 25°C. Please note, if the battery has an average life of 5 years at a working temperature of 20°C, the life is halved if the working temperature is increased to 30°C.

To maintain the temperature of the installation room to within the range indicated above, there must be a system for eliminating the dissipated heat (the UPS kW / kcal/h / B.T.U./h dissipation values are shown in the table below). The methods that may be used are:

- *Natural ventilation.*
- *Forced ventilation*, recommended if the outside temperature is less (e.g. 20°C) than the temperature at which the UPS or Battery Cabinet is to be operated (e.g. 25°C).
- *Air-conditioning system*, recommended if the outside temperature is higher (e.g. 30°C) than the temperature at which the UPS or Battery Cabinet is to be operated (e.g. 25°C).

AMBIENT AND DIMENSION DETAIL

Table 1

Ambient temperature for the UPS	0 - 40°C (0 – 30 °C with vertical exhaust option installed)
Recommended temperature for battery life	20 - 25°C
Range of relative Humidity	5 - 95% (without condensing)
Maximum Operating Altitude (according with IEC/EN 62040-3)	Full power up to 1000 m a.s.l. (power derating of 0.5% for each 100 m between 1000 and 3000 m)
Storage Temperature	UPS: -25°C ÷ +60°C
Isolation protection	IP20
Colour	RAL 9005
Ventilation	Forced, front to rear
Cable entry	BOTTOM or on the REAR (Top with optional side cabinet)
Pollution degree	PD2
Vibration resistance	1 m/s ²
Overvoltage category / Protective class	OVC III / class I
Cabinet Dimension (WxDxH) [mm]	600 x 940 x 1995
Shipping Dimension (WxDxH) [mm]	750 x 1150 x 2135
Shipping Weight Power Cabinet [kg]	258
Net Weight without power modules / Bypass module Included [kg]	244
TOTAL Net Weight with 5 power modules / Bypass module Included [kg]	429

ELECTRICAL INFORMATION TABLE

Table 2

	300 kVA	
Power [kVA / kW]	300 / 300	
V Input [V]	380-400-415 (3PH + N)	
Frequency Input [Hz]	50 - 60	
V Output [V]	380-400-415 (3PH + N)	
Frequency Output [Hz]	50 / 60	
Max Leakage Current [mA] ⁽¹⁾	100	
PM Model	PM BLUE	PM
Power dissipated @ 100% three-phase load ⁽²⁾	8.96 kW 7704 kCal/h 30585 B.T.U./h ⁽³⁾	13.48 kW 11591 kCal/h 46016 B.T.U./h ⁽³⁾
Flow rate of the fans for removing the heat from the installation room ⁽⁴⁾	5555 m ³ /h	8358 m ³ /h

⁽¹⁾ The load leakage current is added to the one of the UPS on the ground protection conductor.

⁽²⁾ Fully charged batteries.

⁽³⁾ 3.97 BTU / h = 1 kcal / h.

⁽⁴⁾ To calculate the air flow rate, the following formula may be used: $Q [m^3/h] = 3.1 \times Pdiss [W] / (ta - te) [^{\circ}C]$
Pdiss is the power expressed in W dissipated by all the devices installed in the installation environment.
ta= ambient temperature, te=outside temperature. To take leaks into account, the value obtained should be increased by 10%.
The table shows an example of a flow rate with (ta - te)=5°C and a rated resistive load (pf=1).
(Note: This formula is applicable if ta>te, only; if the UPS installation does not require an air-conditioning system).

ELECTROMAGNETIC COMPATIBILITY

This UPS product conforms to the current electromagnetic compatibility (EMC) regulations (C3 category). It may cause radio interference in the home environment. The user may have to adopt supplementary measures.

This product is for professional use in industrial and commercial environments. Connections to USB must be made with the cable provided.

OPERATIVE PROCEDURES

For the correct procedures to switch on/off the system, refer to the User Manual.

OVERVOLTAGE PROTECTION

The UPS has been designed to be powered by an AC mains supply with category 2 voltage spikes. If it is connected to an AC supply with different characteristics or if it is potentially subject to transitory overvoltage, external protection equipment must be installed to it.

POSITIONING INFORMATION

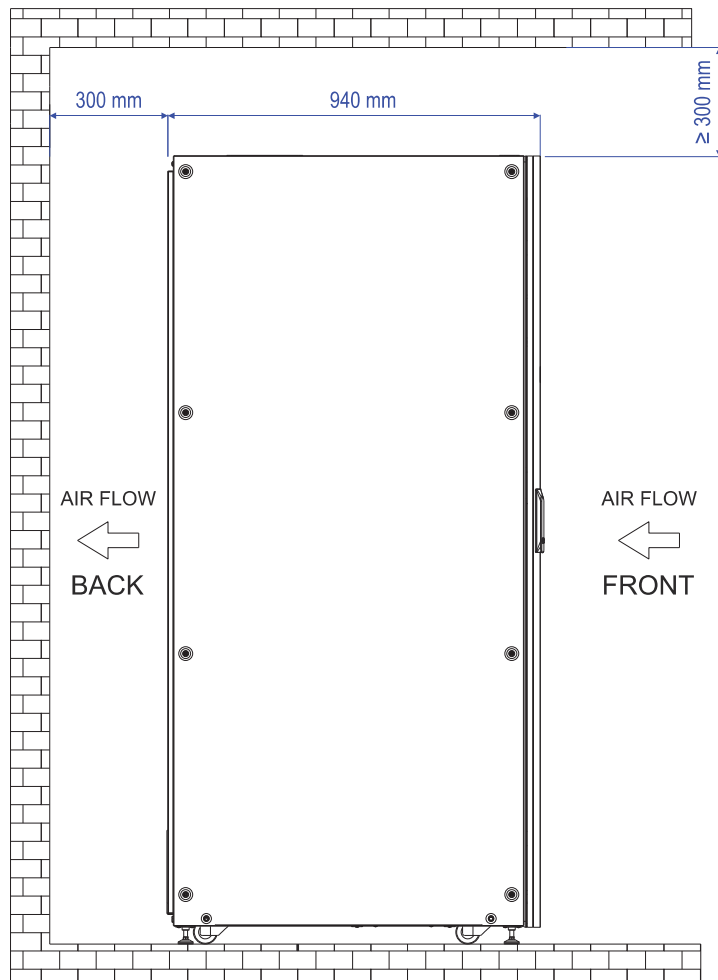
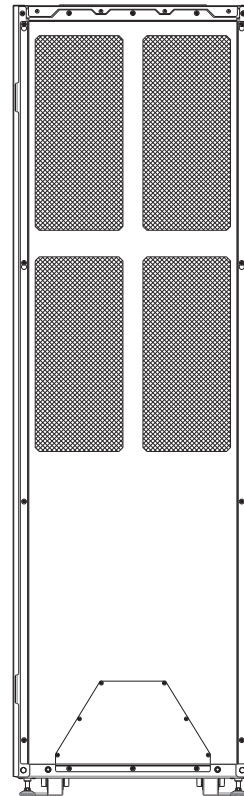
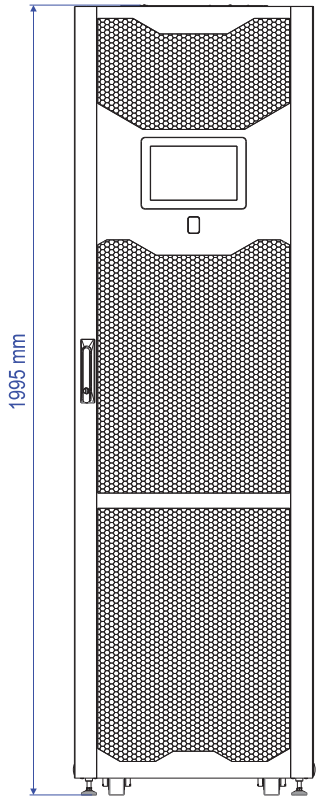

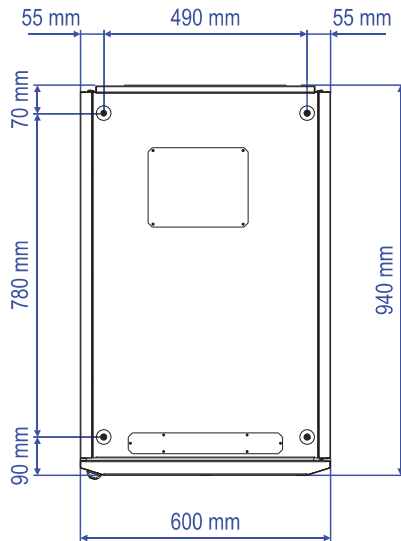

FRONT
TOP VIEW

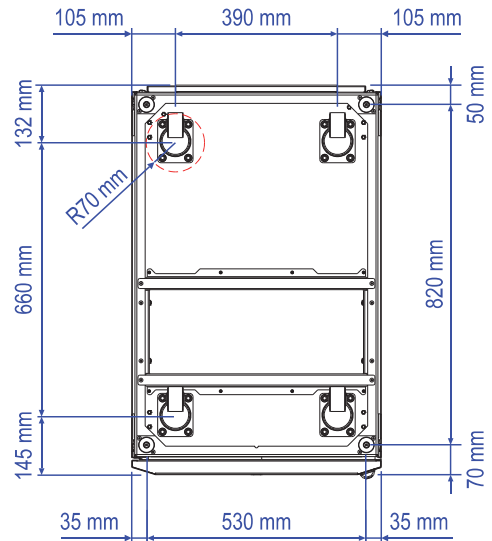

FRONT
BOTTOM VIEW

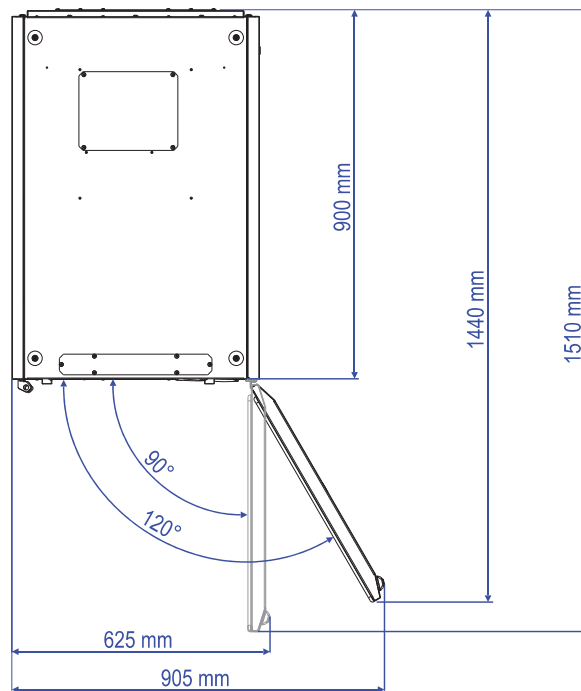

CABINET POSITIONING

Warning! The cabinet cannot be moved and/or delivered to site with the Power Modules inserted.

When positioning, take into account that:

- the cabinet must be positioned without the Power Modules inserted; the Power Modules can only be inserted once the cabinet feet have been lowered.
- The wheels are to be used for final positioning only. Specialist moving equipment must be used to transport the UPS near to the final position.
- Plastic parts and the door are not able to act as pushing points or handles.
- You will need to ensure at least enough free space in front of the cabinet for user operation and maintenance (≈ 1.1 m).
- Do not place any objects on the top. Do not climb up on the Cabinet. The chassis isn't designed to hold up the weight of a person.



Warning! The cabinet must be positioned on a level floor.
Ensure that the floor can support the total weight of the system.
The weight of the Power Cabinet full of Power Modules is 429 kg.

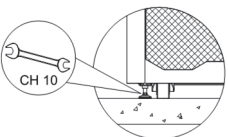

**After positioning, lower the four feet to the floor, using an appropriate spanner.
Ensure that the total weight of the cabinet is supported by the feet only (the revolving wheels must be lifted from floor).
Ensure that the Power Cabinet is level.**

It is advisable to reuse the pallet fastening brackets to anchor the Power Cabinet to the floor.

UPS PARTS AND MODULES

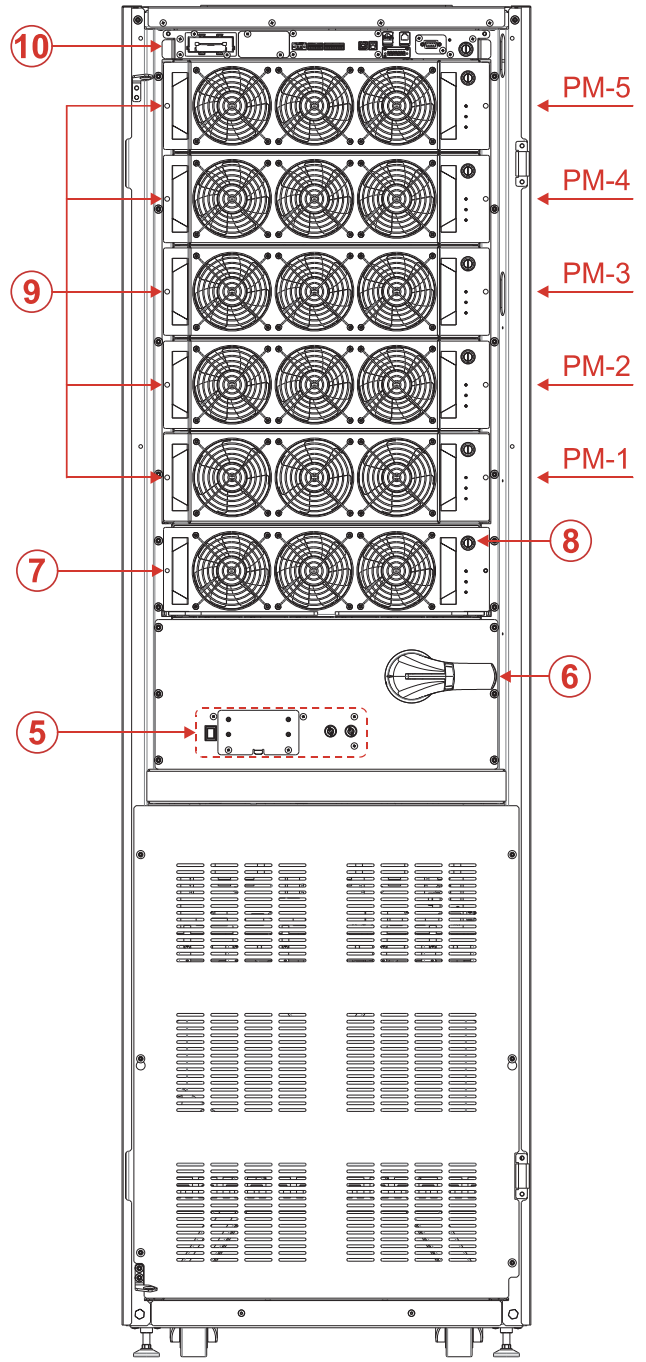
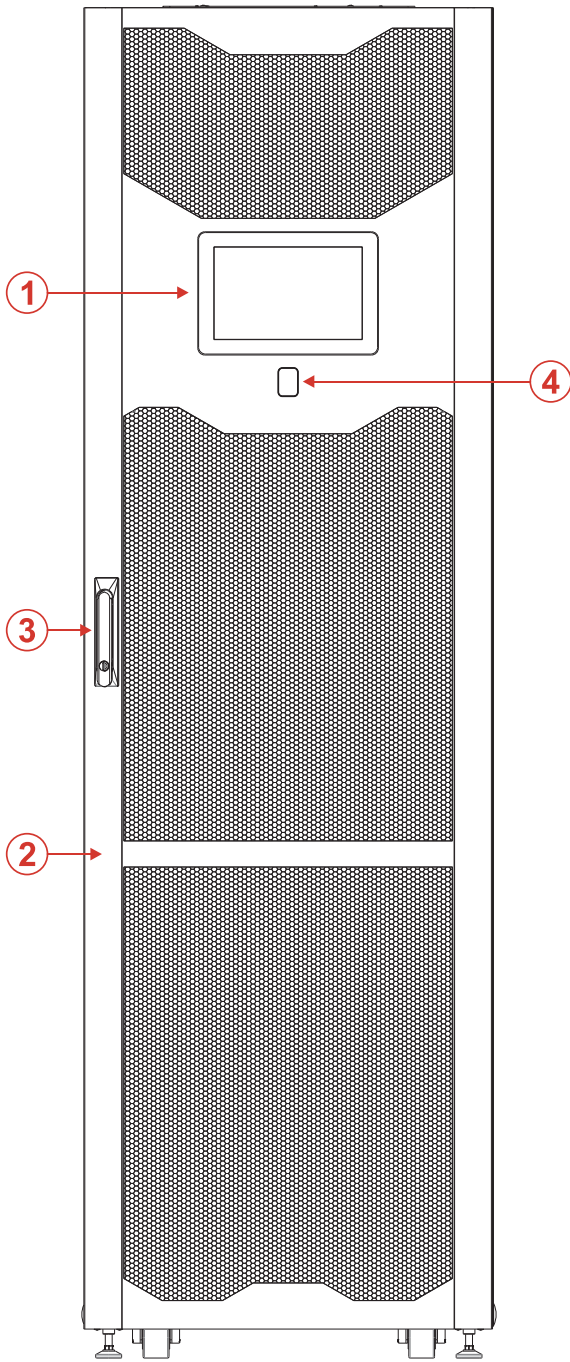

- ① Display (MCU)
- ② Door with air filter
- ③ Handle
- ④ UPS status LED
- ⑤ Cold Start section (*optional*)
- ⑥ Manual Bypass switch
- ⑦ Bypass Module (BM)
- ⑧ Switch Lock
(locking system present on all modules)
- ⑨ Power Module (PM)
- ⑩ Connectivity panel



WARNING! The cabinet cannot be moved and/or delivered on site with Power Modules inserted.

POWER CONNECTION INFORMATION

Protective Earth PE			
Power [kW-kVA]	Terminal PE Bolt [Nm]	Wire	
		Type	Cross sectional area Cu [n. x mm ²]
300	M10 35 Nm	90°C FG16R16-0,6/1 kV or equivalent	1 x 95

Input AC Line Connection 3PH + N (Single / Dual Mains)							
N module	Max Power [kW-kVA]	Max current ⁽¹⁾ [A]	Max admitted neutral current [A]	Size of line protection device (plant) ⁽²⁾ [A]	Terminal IN1, IN2, IN3, N Bolt [Nm]	Wire IN1, IN2, IN3, N	
						Type	Cross sectional area Cu [n. x mm ²]
1	67	121	168	125	M10 35 Nm	90°C FG16R16-0,6/1 kV or equivalent	2 x 95
2	134	241	300	250			
3	201	362	397	400			
4	268	483	495	500			
5	300	573	573	630			

BYPASS AC Line Connection 3PH + N (Dual Mains)						
Max Power [kW-kVA]	Max nominal current [A]	Max admitted neutral current [A]	Size of line protection device (plant) [A] ⁽²⁾	Terminal BYP1, BYP2, BYP3, N Bolt [Nm]	Wire BYP1, BYP2, BYP3, N	
					Type	Cross sectional area Cu [n. x mm ²]
300	435	573	500	M10 35 Nm	90°C FG16R16-0,6/1 kV or equivalent	2 x 70

Output AC Line Connection 3PH + N								
N module	Max Power [kW-kVA]	Max nominal current ⁽³⁾ In [A]	Max admitted neutral current [A]	Terminal OUT1, OUT2, OUT3, N Bolt [Nm]	Wire OUT1, OUT2, OUT3, N / PE		Output line protection (recommended values for selectivity)	
					Type	Cross sectional area Cu [n. x mm ²]	Normal Fuses (gL - gG)	Thermal magnetic switches (C curve)
1	67	97	168	M10 35 Nm	90°C FG16R16-0,6/1 kV or equivalent	2 x 70 [PH] 2 x 95 [N]	In/4	In/4
2	134	194	300					
3	201	291	397					
4	268	388	495					
5	300	435	573					

Input Battery DC Line Connection BATT+, BATT-							
N module	Max Power [kW-kVA]	Rated Current [A] ⁽⁴⁾		Sized of battery line protection device [A] ⁽²⁾	Terminal BATT +, BATT - Bolt [Nm]	Wire BATT +, BATT -	
		@nominal battery voltage	@end of discharge voltage			Type	Cross sectional area Cu [n. x mm ²]
1	67	146	175	180	M10 35 Nm	90°C FG16R16-0,6/1 kV or equivalent	2 x 120
2	134	292	351	350			
3	201	438	526	500			
4	268	585	702	700			
5	300	655	785	800			

(1) Input voltage at 364 V and battery charger on

(2) If possible, set the protection closest to the maximum current

(3) Output voltage at 380 V

(4) With 40 battery blocks of 12 V

SYSTEM PROTECTIONS INFORMATION



THE INPUT, OUTPUT AND PROTECTIVE EARTHING CONDUCTORS MUST BE SIZED FOLLOWING THE RATED VOLTAGE AND CURRENT, AS SHOWN IN THE TABLES AND ALSO COMPLY WITH LOCAL AND NATIONAL REGULATION FOR MAXIMUM POWER RATING.

WARNING

THE PROTECTIVE EARTHING CONDUCTOR (PE) MUST BE CONNECTED PRIOR TO CONNECTING ANY INPUT / OUTPUT CABLES.

INPUT LINE PROTECTION

Install a line protective device upstream the UPS. Refer to section "Power Connection Information" to set the right size. In case an automatic circuit breaker is used, a $5-10 \times I_n$ magnetic trip threshold is recommended.

If the device interrupts the neutral wire, it must also interrupt all of the phase wires at the same time.

The disconnect device shall have a contact separation of at least 3 mm

SHORT CIRCUIT PROTECTION

If a failure at the output occurs, the UPS protects itself by limiting the value and duration of the output current (short-circuit current). These values also depend on the operating status of the UPS at the time of the failure; there are two different scenarios:

- UPS in NORMAL OPERATION with the bypass input available: the load is instantly switched to the bypass line; the input line is connected to the output via static switch limited by the internal protection (pre-arcing fuse bypass $I^2t = 25000A^2s$) and blocked after $t > 500ms$.
- UPS in BATTERY OPERATION or in NORMAL OPERATION without a bypass supply: the UPS protects itself by supplying 2.5 times the nominal current to the output for the first 100ms, which is then reduced to 1.5 times nominal for 400 ms. After this time (500 ms) it switches off.

SHORT-CIRCUIT WITHSTANDING

If the internal manual bypass is enabled

$I_{cc}=50kA$

- With upstream fuses (comply to the standard IEC 60269)
These devices must have the following technical features:
 - type gG/gL 500 A;
 - let through energy $\leq 2,2 \times 10^6 A^2s$

If the internal manual bypass is NOT enabled (the switch manual bypass is locked and only the static bypass is usable)

$I_{cc}=100kA$ (current limited of internal fuses)

BACKFEED PROTECTION

The UPS has an internal protection against backfeed. This protection acts by means of a sensing circuit which turns the inverter off if a fault within the static switch is detected. During this condition, to avoid interrupting the supply to the connected load, the UPS switches to the bypass line.

If this fault occurs during battery operation, the inverter is stopped.

A volt free contact can be configured to drive a disconnecting device to be installed upstream the bypass input to the UPS, in this case when a backfeed fault occurs, the system opens the external disconnecting device, hence avoiding the requirement to stop the inverter.

Warning: use the service configuration software to set this option.

The current rating of the disconnecting device must comply with the instruction outlined in the "Power Connection Information" section.



The label supplied with the UPS named "Risk of Voltage Backfeed" and included in the accessory box, must be affixed to all disconnectors installed within the electrical system upstream of the UPS.

RCD BREAKER (RESIDUAL CURRENT DEVICE)

If an input isolation transformer is not present, the neutral from the mains power supply is connected to the UPS output neutral. As a result, there will be no change to the neutral arrangements of the installation:

THE UPS INPUT NEUTRAL IS CONNECTED TO THE UPS OUTPUT NEUTRAL THE DISTRIBUTION SYSTEM THAT POWERS THE UPS IS NOT MODIFIED BY THE UPS



The neutral condition is only modified if an isolation transformer is present or when the UPS works with the neutral isolated upstream.

Make sure that the equipment is properly connected to the input neutral, otherwise serious damage can occur to the UPS.

During normal operation, when the mains supply is present, an RCD breaker at the input of the UPS will activate if a fault occurs at the output side, since the output circuit is not isolated from the input.

In any case, other RCD breakers may still be installed at the output, preferably in coordination with those present at the input.

The earth leakage current may exceed 3.5mA, so the RCD breaker located upstream must have the following characteristics:

- Differential current adjusted to the sum of UPS + Load; we recommend keeping a suitable margin to prevent nuisance tripping (1A recommended)
- Type B
- Delay of at least 0.1s

NOTE for DUAL INPUT connection:

1. A single RCD breaker must be installed upstream at the point where the sources divide to supply the standard input and the bypass input of the UPS.
2. If the standard input and the bypass input are supplied from two separated sources, then it is required to use a dedicated RCD device for each source.

REMOVING DOOR

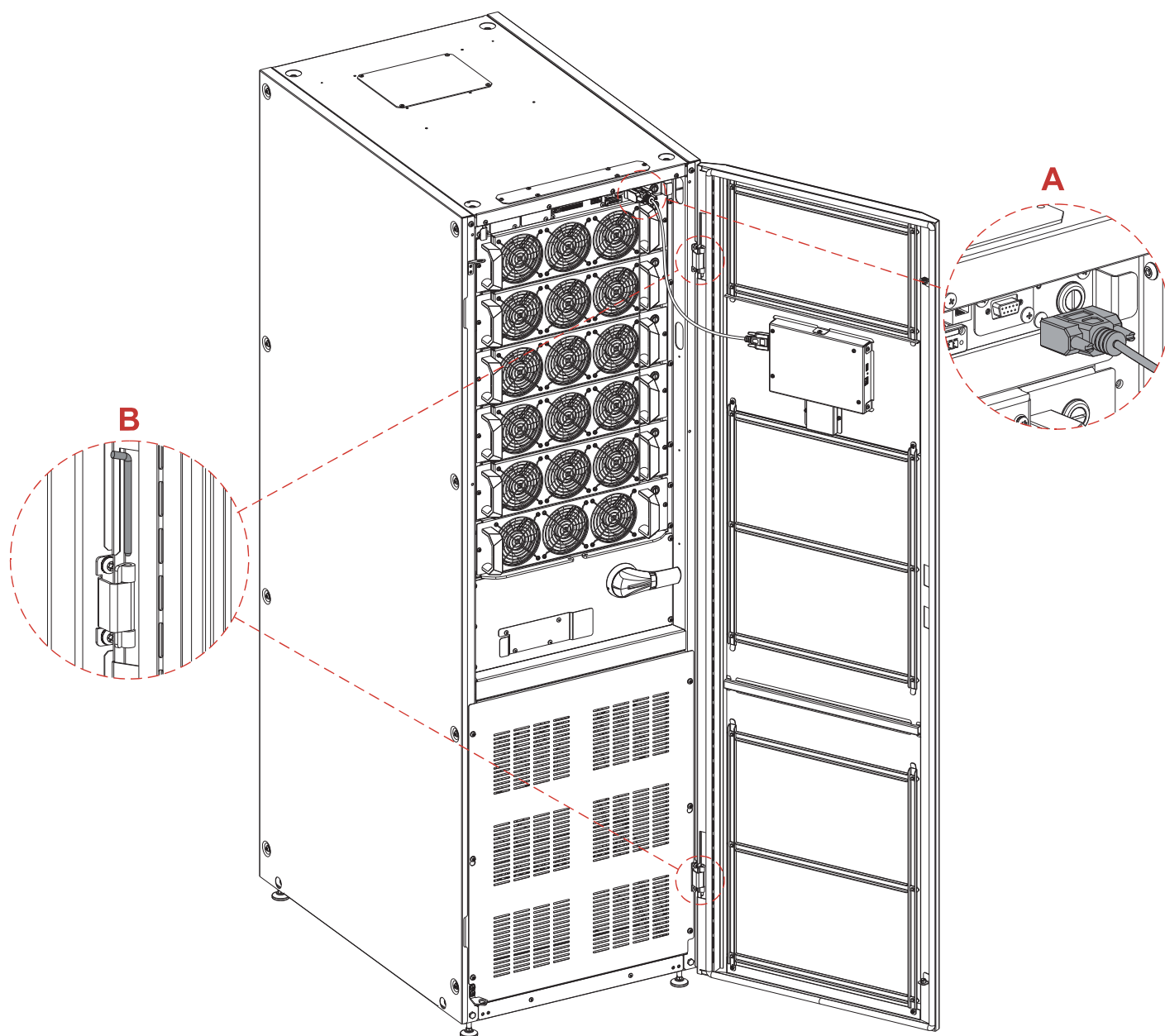

A. Disconnect display cable

B. Remove hinge pins

POWER CONNECTION DETAIL



REMOVING TERMINAL CONNECTION PROTECTION COVERS
BEFORE REMOVING THEM, THE SYSTEM MUST BE COMPLETELY ISOLATED FROM ALL POWER SOURCES.

Remove the terminal connection protection covers as shown in the figures below.

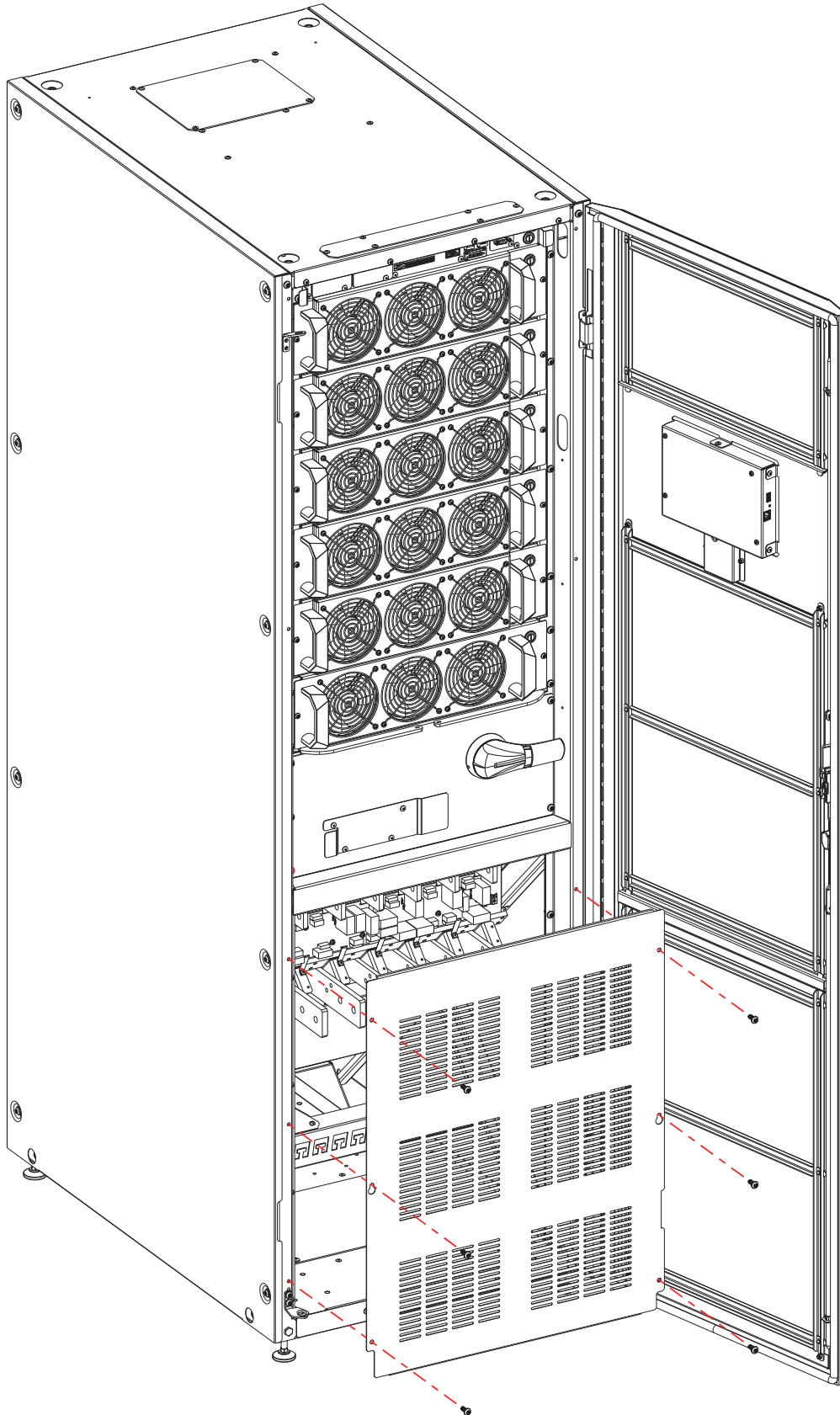



ATTENTION: CONNECT THE WIRES IN THE CORRECT POSITION.

Wrong connections can cause damage to the UPS or the loads.

Do not reverse the polarity of the batteries.

Refer to the operative procedures section within the User manual.

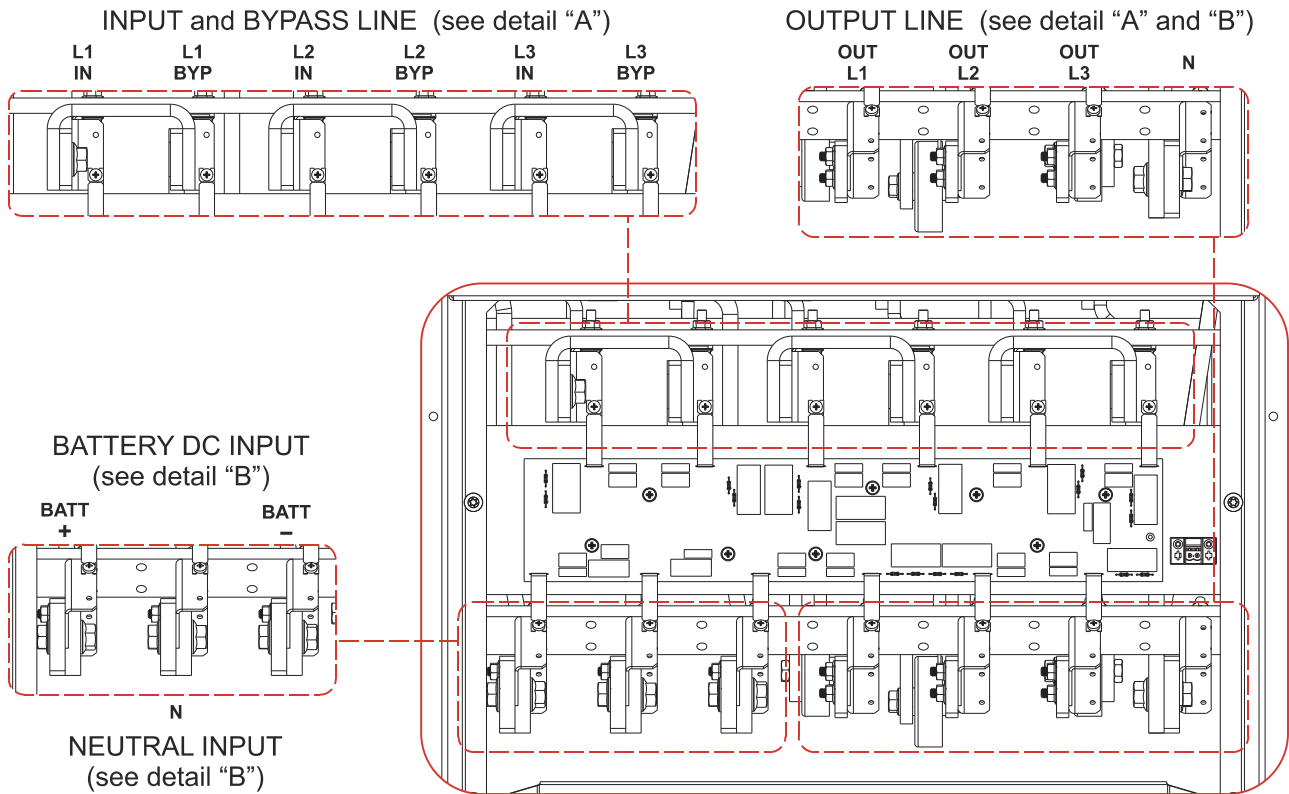

WARNING! This UPS does not need battery central point. Only connect + and - battery terminals to the relative bars.

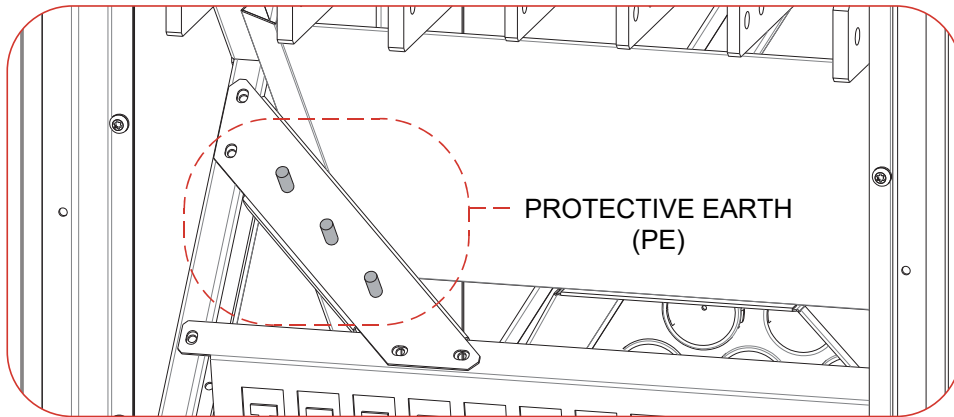

DETAIL "A"
INPUT, BYPASS, OUTPUT connection cables
Torque 35 Nm

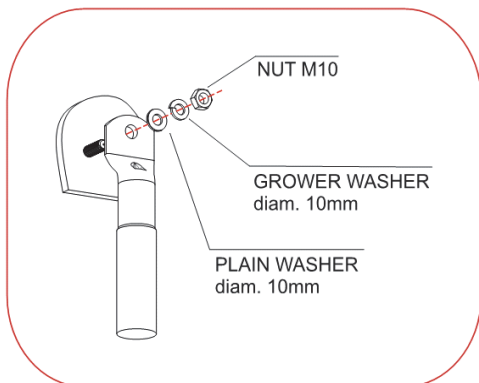

DETAIL "B"
NEUTRAL and BATTERY connection cables
Torque 35 Nm

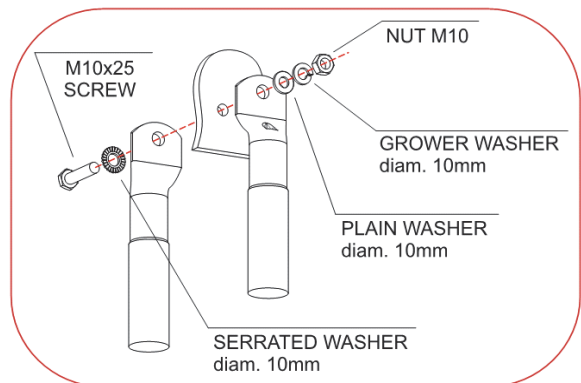

BOTTOM CABLE ENTRY

1. Drill holes for the cables in the bottom aluminum cover (e.g. in case of floating floors) or in the rear aluminum cover (in case of floor-level cable ducts). See figures below.
2. To comply with IP20 protection degree, make sure that the holes size is slightly larger than the wires diameter.
3. Insert conduits (if applicable) or ensure that any sharp edges, which could possibility damage cables, have been removed.

Cable entry for floating floors

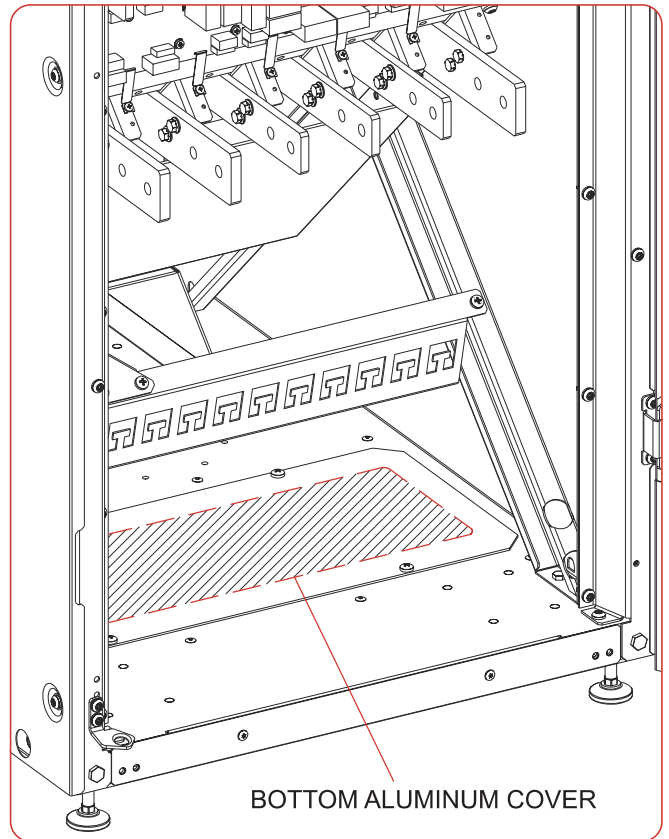

BOTTOM ALUMINUM COVER

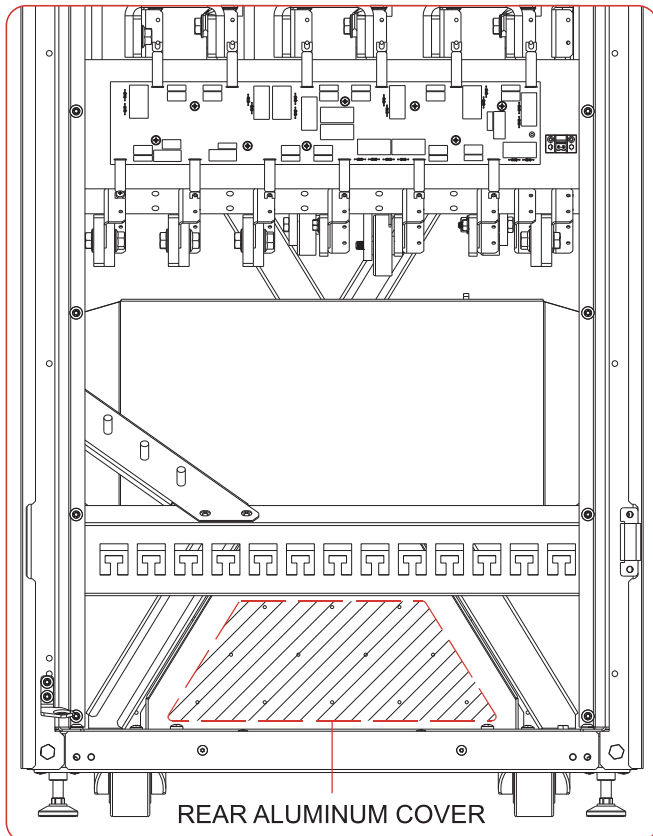

REAR ALUMINUM COVER

Cable entry for floor-level cable duct

JUMPER REMOVAL FOR DUAL INPUT

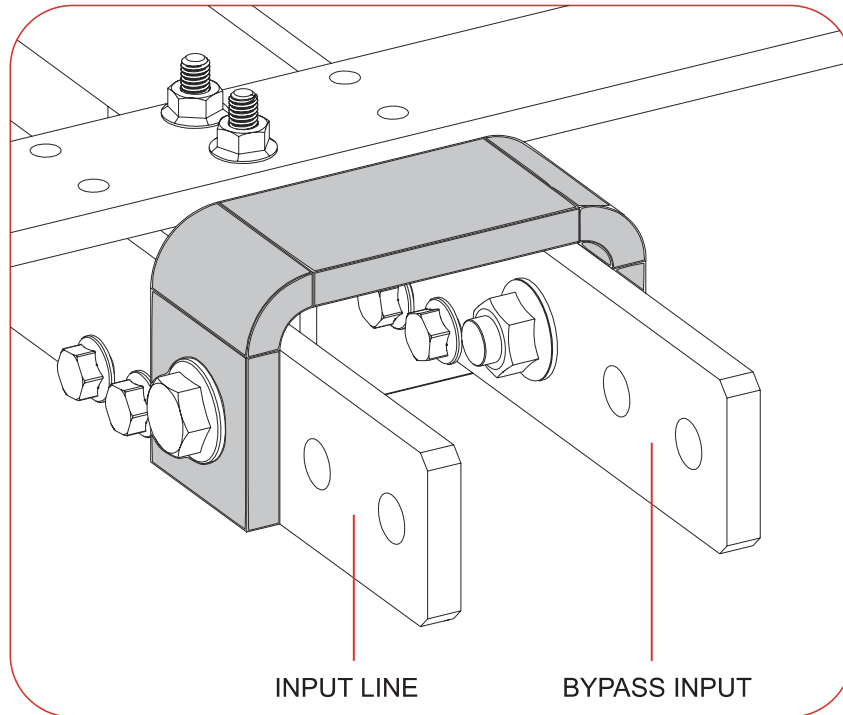

To remove the single-input connection jumpers, unscrew the two M10 bolts and extract the “U” shaped bars that join bypass and input lines for each one of the three phases.

EXTERNAL SYNC

Insulated input to synchronize the output of the UPS to an external source. Use the service configuration software to enable and set the external sync function.

Input parameters: Phase – Neutral max. 230 Vac \pm 10%

Connection wires: 1.5 mm² double insulation

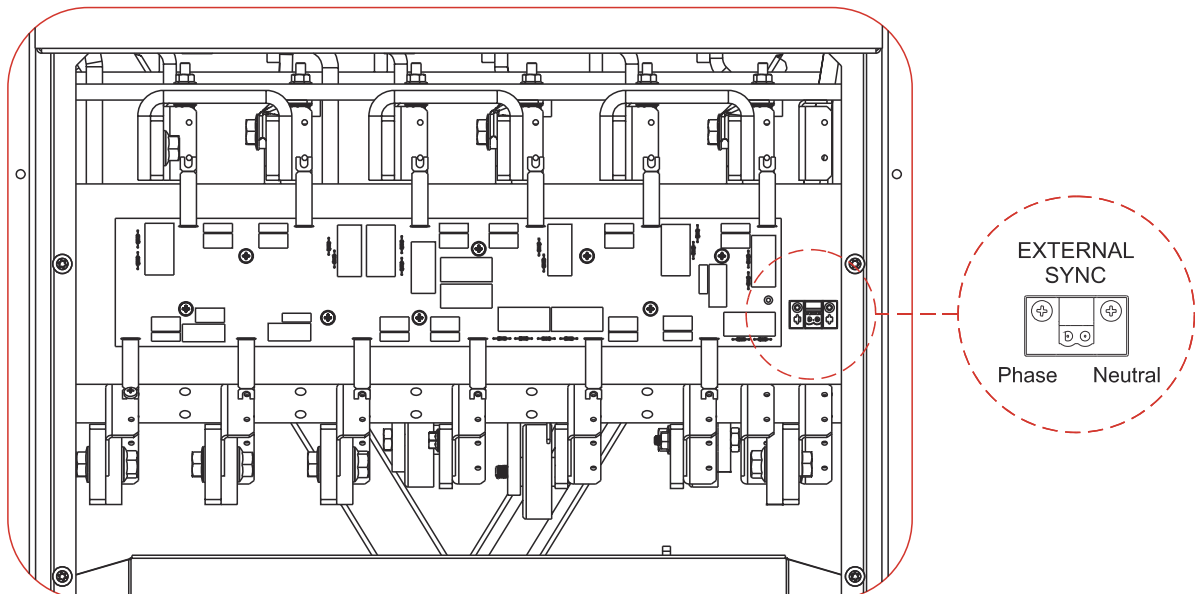

The phase 1 inverter output of the UPS will be synchronised with the connected external source

POWER CONNECTION POSITIONS

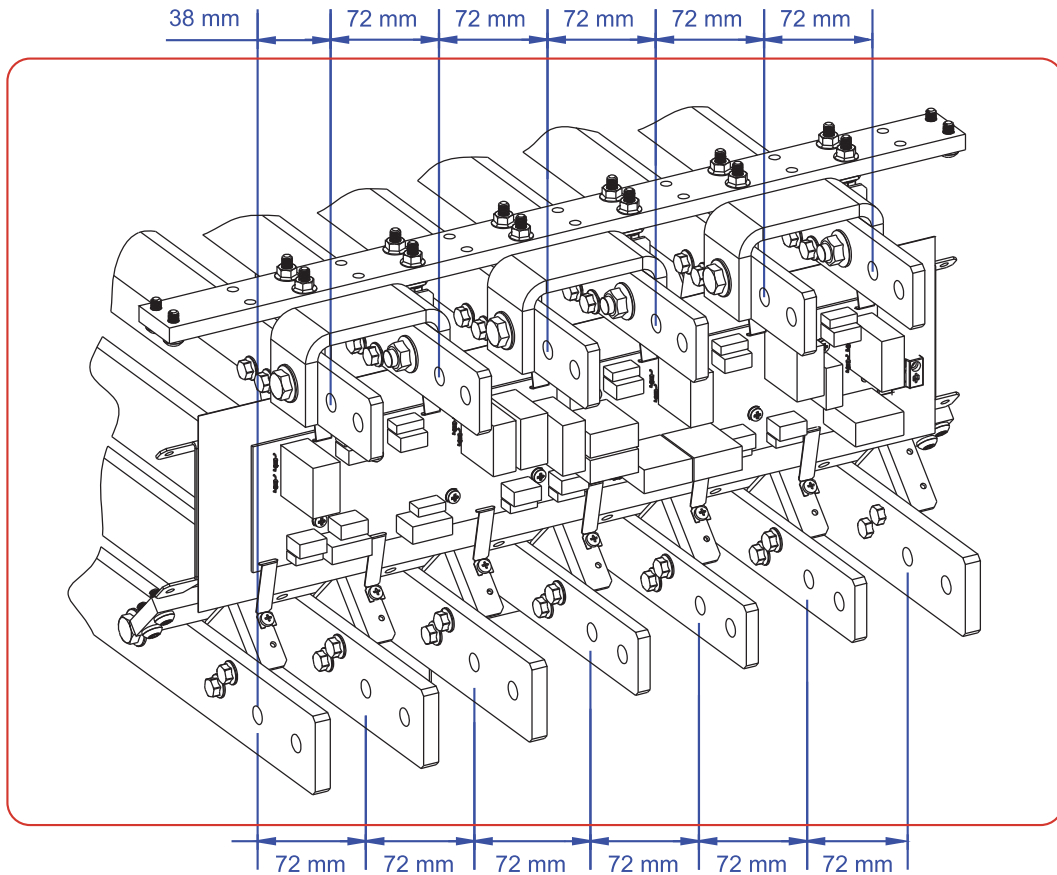
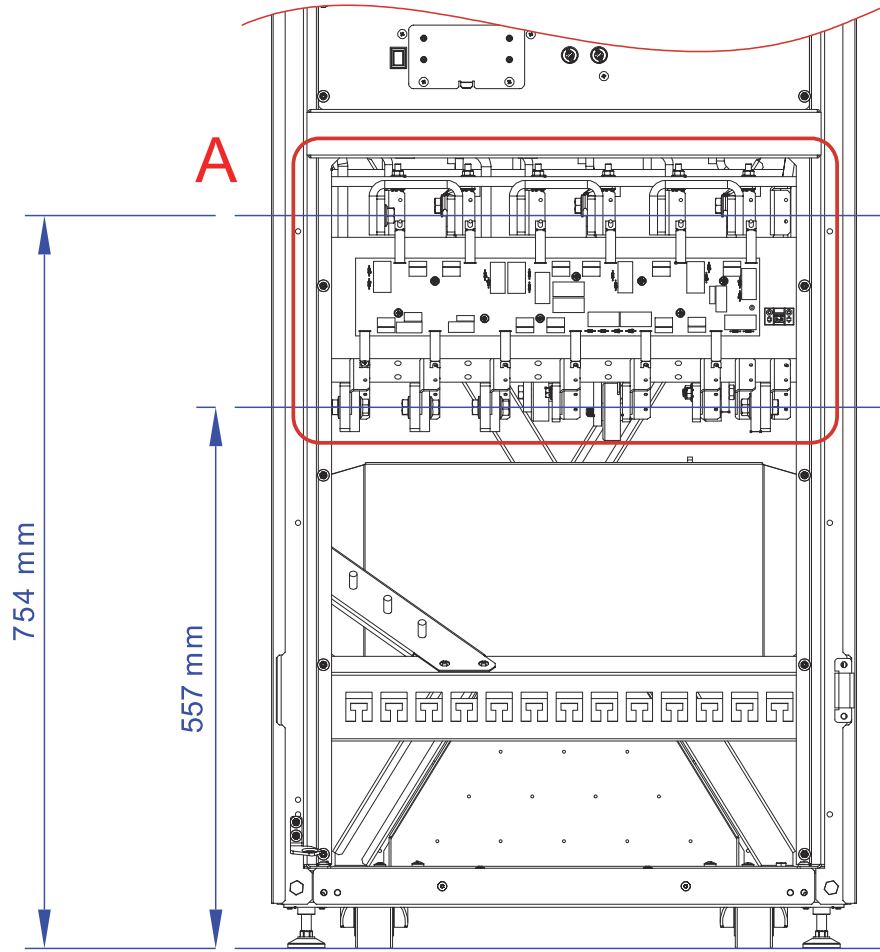

DETAIL A

EARTH CONNECTION POSITION

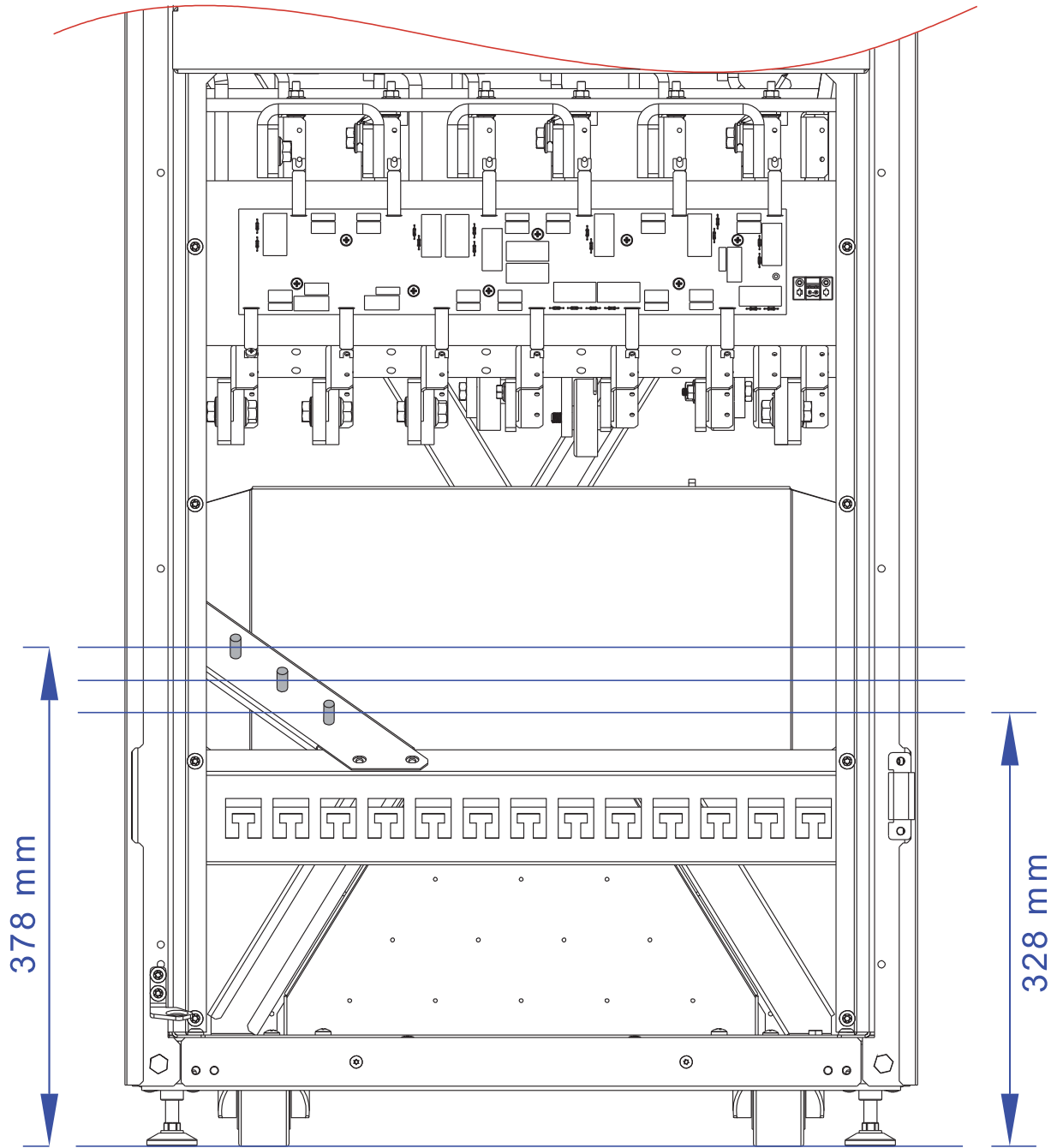

REPLACING DOOR AIR FILTER [OPTIONAL]

An on-site installation special door is available as a kit with special dust filtering on this UPS series. This kit is designed for UPS located within a dusty environment.

The adding of the filter, if correct maintenance works are carried out, does not reduce the performance of the UPS (No power derating).



Regularly clean the air filter according to the environmental conditions.

1. Remove the locking nuts as shown in the figure below and store them.

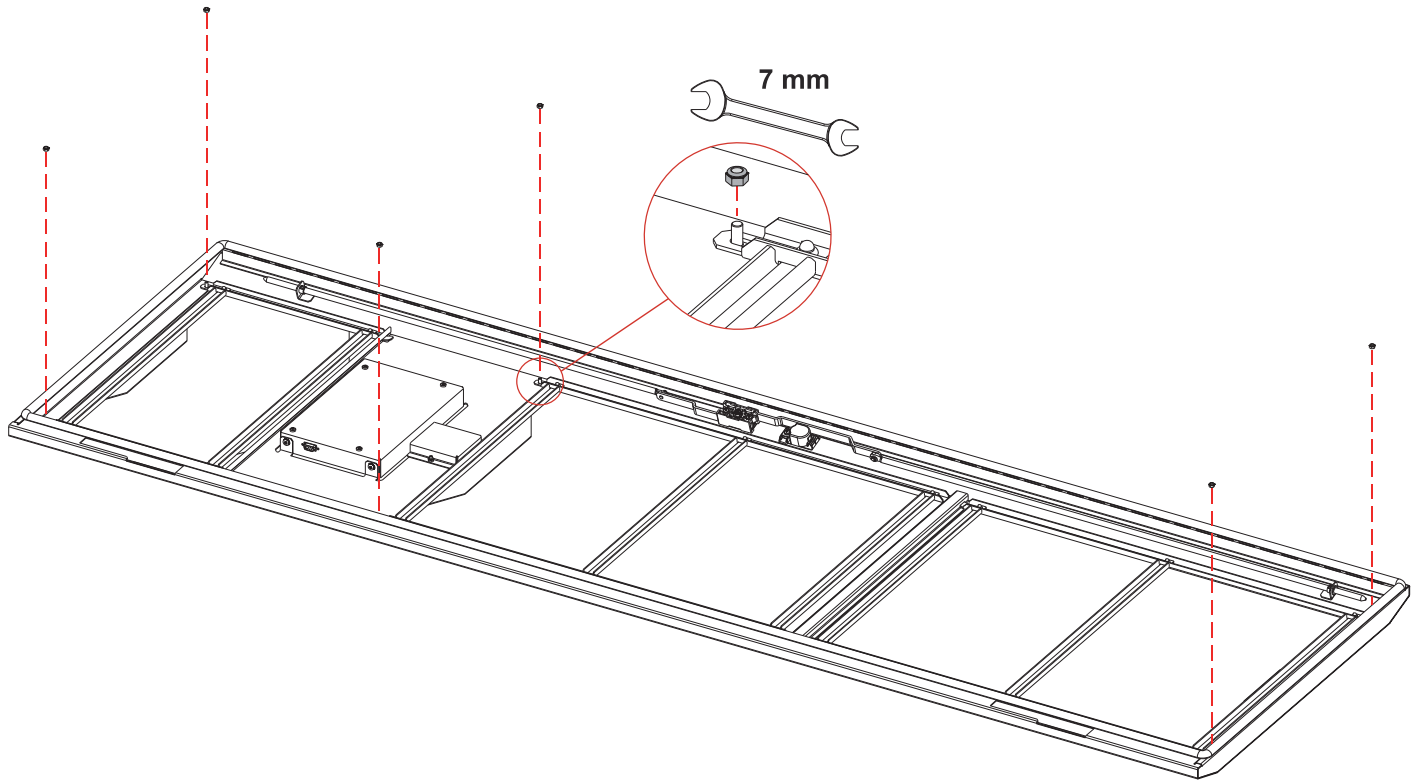

2. Remove the air filter frames by lifting them up as shown in the following figure.

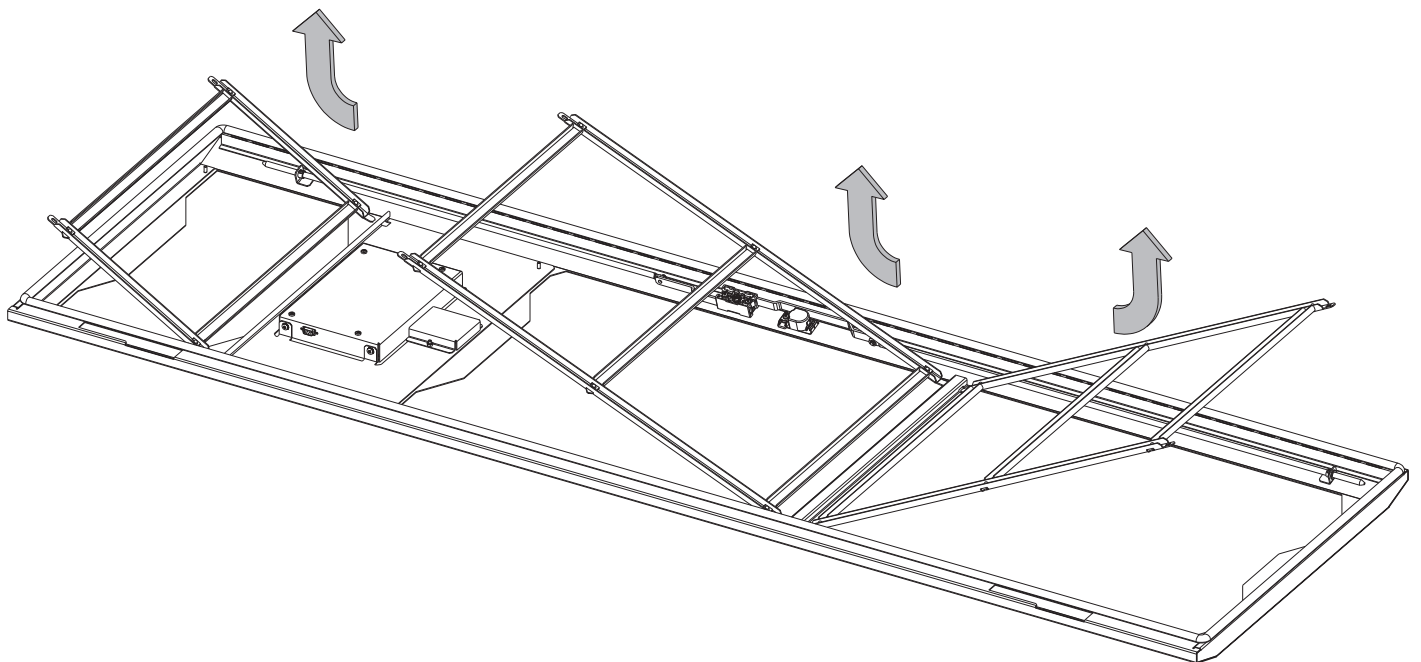

3. After replacing the filters, follow the above procedure in reverse to reassemble the frames.

VERTICAL EXHAUST [OPTIONAL]

Through the "Vertical Exhaust" option, it is possible to modify the air expulsion flow (from the top of the UPS rather than from the back).

Below, the Vertical Exhaust is highlighted and the differences in size and positioning from the standard model are reported.



ATTENTION:

With the Top Ventilation Kit option the maximum allowed ambient temperature for the UPS decreases from 40°C to 30°C. The Vertical Exhaust can be installed on the UPS only when PM67 BLUE modules are used. It is not compatible with other module types.

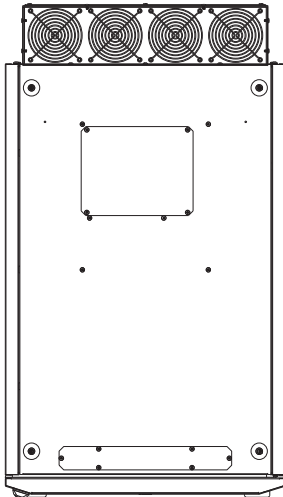

FRONT
TOP VIEW

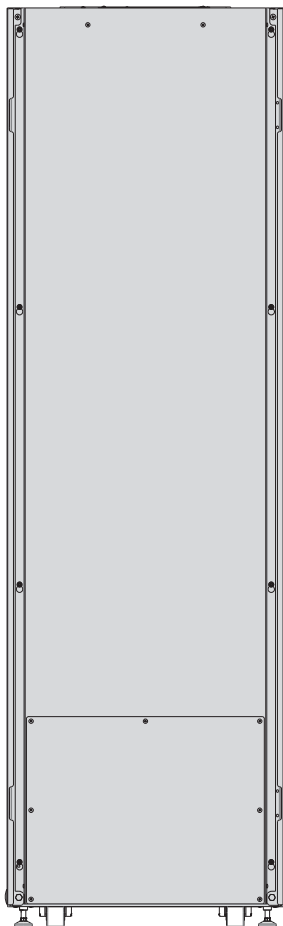

REAR VIEW

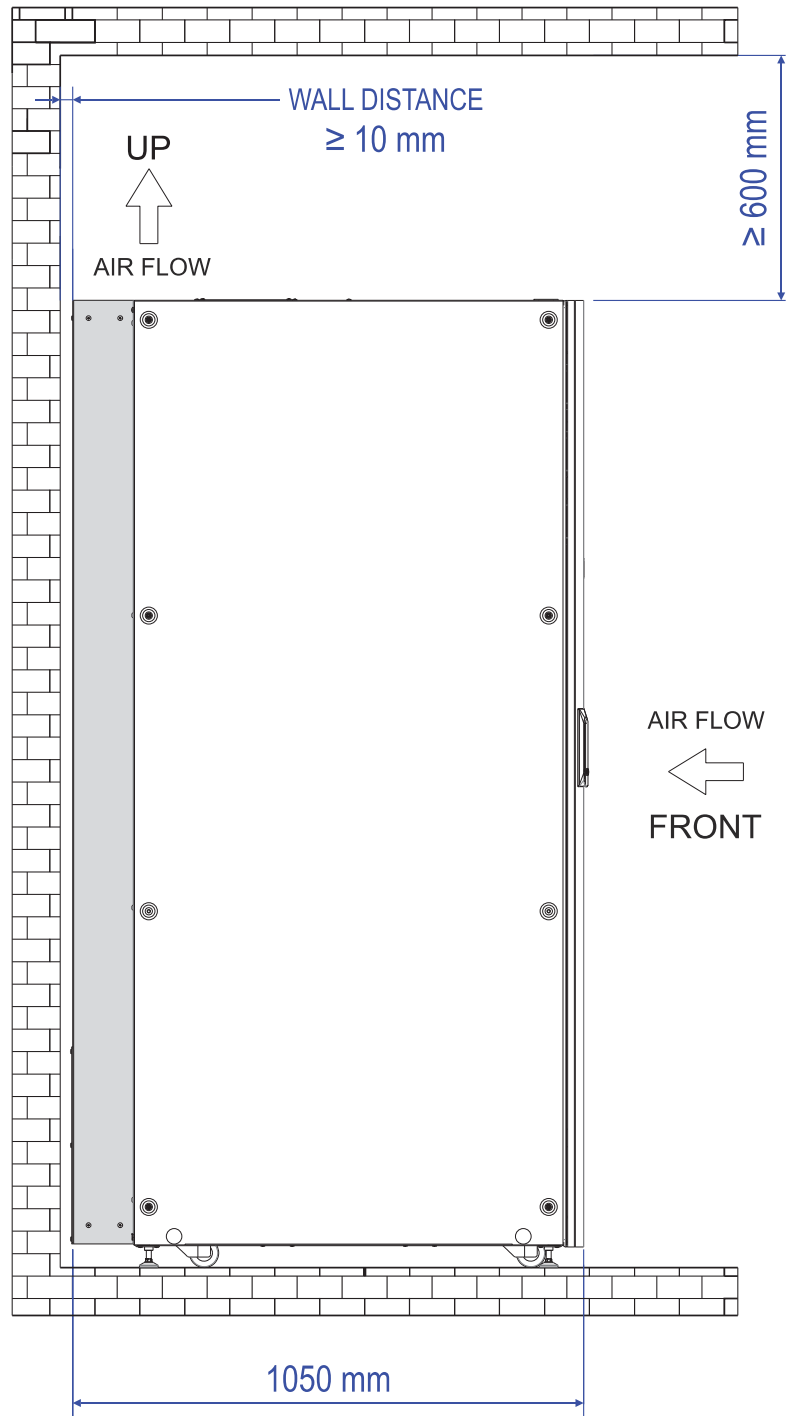

SIDE VIEW

INSERTION/EXTRACTION MODULES AND UNITS PROCEDURE

POWER MODULE (PM)

POWER MODULE (PM) - Net weight 37 Kg

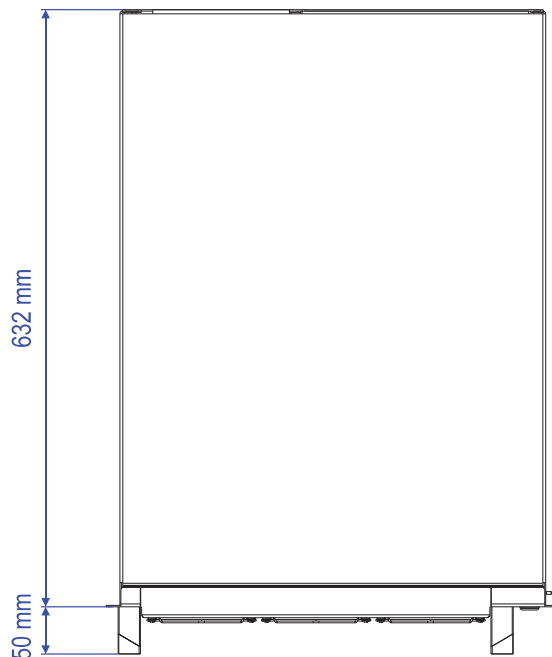
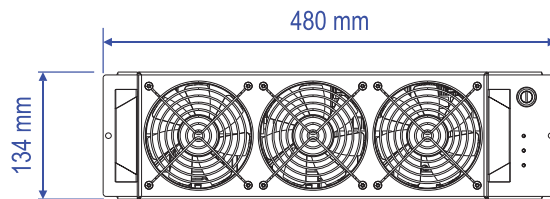
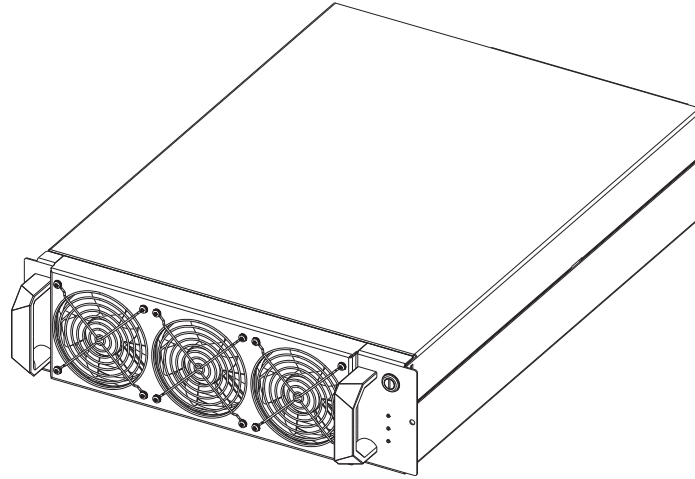

The following operations must only be performed by skilled and specifically trained personnel.

When the PM is not inserted, uncovered parts with dangerous voltage are present within the corresponding backplane.

Use Personal Protective Equipment (see "Important safety information" section).



The PM, due to its weight, must be handled by at least two persons.

Strictly comply with the instructions as listed below.

INSERTION

1. **Note: the PM must be inserted in the slot of a previously removed one or, in case of first installation, in the first free dedicated slot of the cabinet, starting from the bottom slot.** If present, remove the protection cover and store it together with the fastening screws.

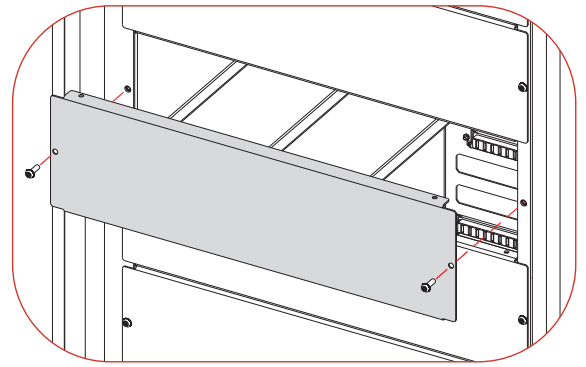

2. Check that the Switch Lock of the PM module to be inserted is in the open position (see figure alongside).

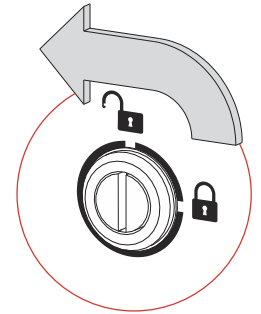

WARNING! Check that all the LEDs are off.

3. Carefully insert the PM into the cabinet (requires two persons) and fasten it using the supplied screws, as shown in the figure.

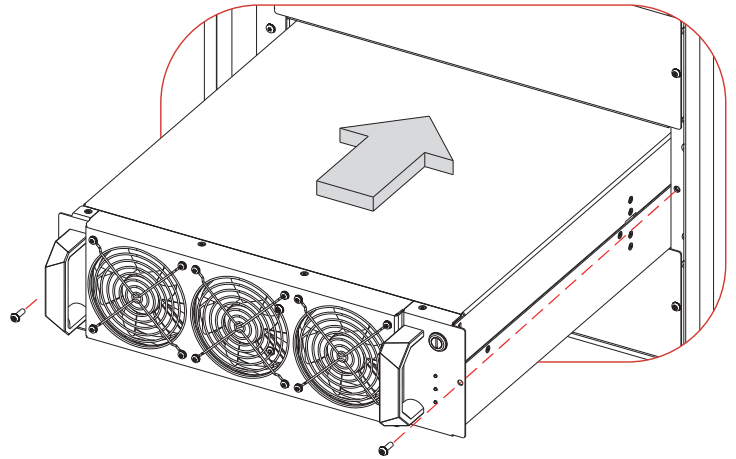

4. Turn the Switch Lock 90° clockwise to the closed position (see figure alongside).

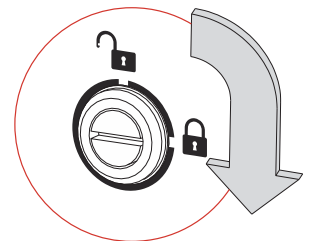

5. Switch on the PM using the display.

EXTRACTION



Note: before extracting any PM, please ensure that the remaining PMs are capable of supporting the full load.

To extract the PM from the cabinet, reverse the procedure described above. In brief:

1. Switch off the PM using the display.
2. Turn the Switch Lock 90° counterclockwise to the open position .
3. Check that the module is in the off state.
4. Remove the two side fastening screws and store them.
5. Using the handles, carefully extract the PM from its housing. This operation requires two persons.
6. **Caution:** when the PM is not inserted, uncovered parts with dangerous voltage are present on the corresponding backplane. Therefore, in the case where a new PM is not immediately inserted, install the supplied protection cover using the dedicated screws.

BYPASS MODULE 500AMP (BM)

Net weight 34 Kg

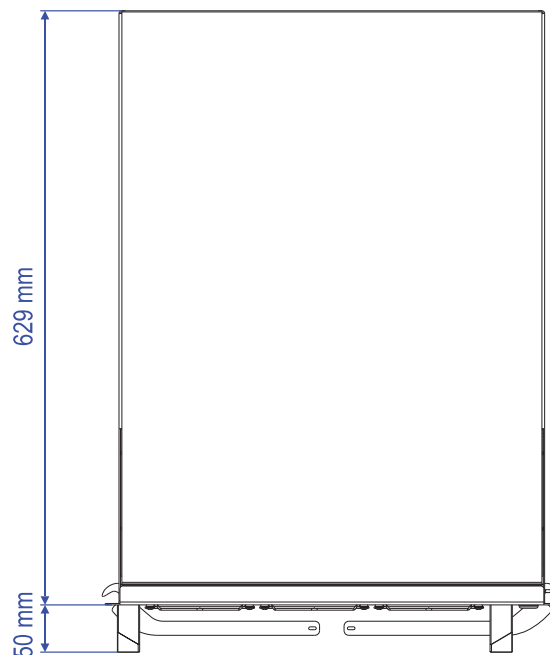
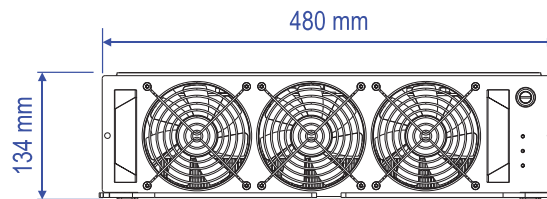
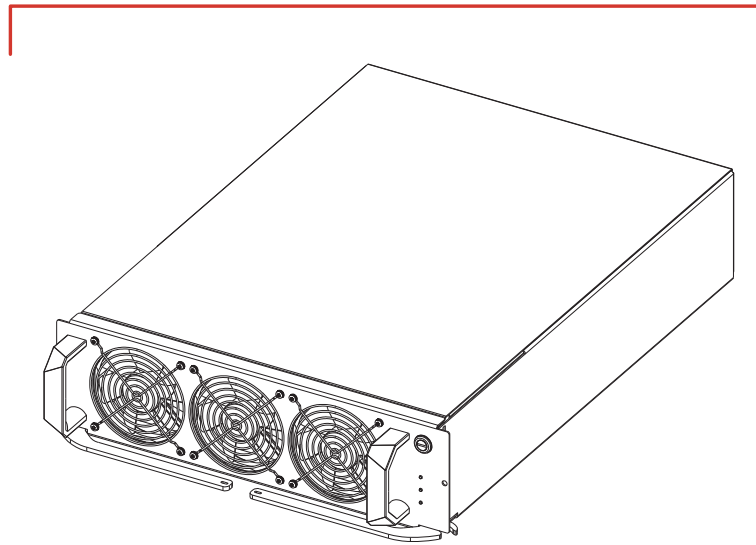

The following operations must only be performed by skilled and specifically trained personnel.



When the BM is not inserted, uncovered parts with dangerous voltage could be present within the corresponding backplane.

Use Personal Protective Equipment (see "Important safety information" section).



Due to its weight, the BM must be handled by two people.

The BM is pre-installed by the manufacturer, extract it only in case of maintenance or replacement.

Strictly comply with the instructions as listed below.

EXTRACTION



WARNING: Before performing the operations below, ensure that the shutting down of the BM does not lead to the loss of the connected load.

It is possible to extract and replace the BM using two different procedures:

- The first procedure (1.1), in **Service Bypass Mode**, is the recommended one and is valid for all types of systems.
- The second procedure (1.2), in **ON Line Mode**, is applicable only in case of UPS with a dedicated switch for the Bypass line.

In this second case it is possible to extract and insert the BM keeping the load powered with UPS in ON Line Mode.

1.1 RECOMMENDED procedure via **Service Bypass Mode**:

- a. Switch the System to Static Bypass Mode. If this operation is not possible, go to point "1.2" directly.
- b. Close the Manual Bypass switch.
- c. Open the Input switch.
- d. Open the Bypass switch
- e. Open the Output switch.
- f. Open the Battery switch.

1.2 ALTERNATIVE procedure with **ON Line Mode**:

- a. Open the Bypass switch.

2. Turn the Switch Lock 90° anticlockwise to the open position (see figure alongside).

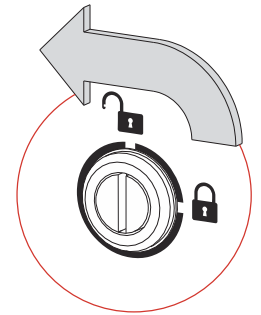

3. Remove the two side fastening screws and store them.

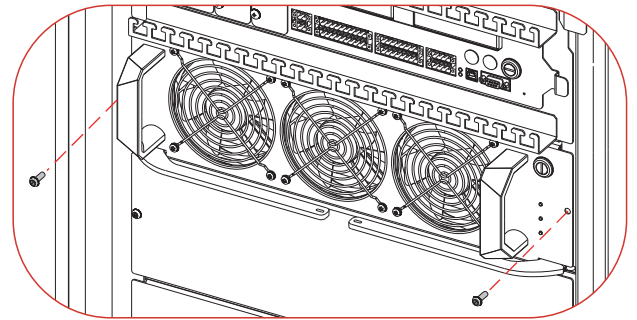

4. To extract the BM, use the levers as shown in the figure to the side.

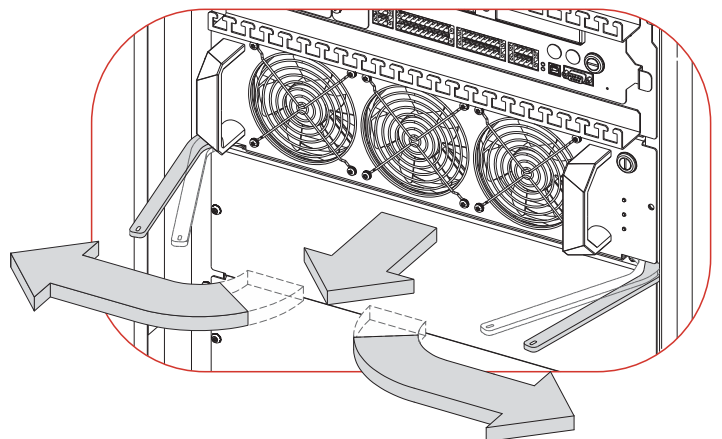

5. Carefully extract the BM from its housing using the appropriate handles. This operation requires two persons.
6. If present, press the latch to unlock the BM as shown in the figure alongside.

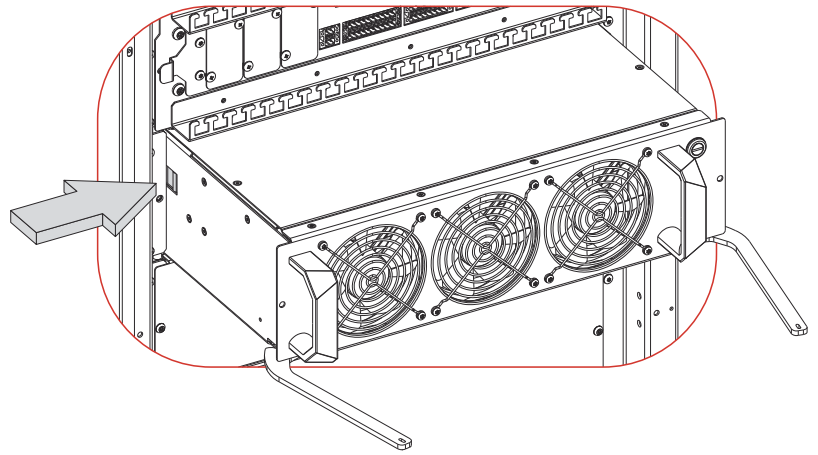

7. **Caution:** in Normal Mode Operation, when the BM is not inserted, uncovered parts with dangerous voltage could be present in the backplane. After removing the module, a new BM must immediately be inserted. See below the Insertion Instructions.

INSERTION

To insert the BM into the cabinet, use the following procedure:

1. Make sure that the UPS is in **Service Bypass Mode**, with all the other switches open or in ON Line Mode with the Bypass switch open (according to the extraction procedure adopted, see the previous Extraction Procedure 1.1 and 1.2).

2. Check that the Switch Lock is in open position  (see figure alongside).

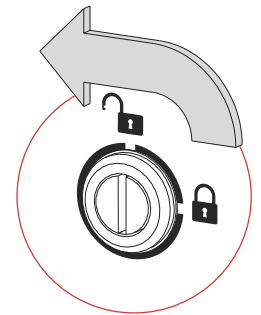

3. Carefully insert the BM into the cabinet (requires two persons). Make sure that the levers are open.

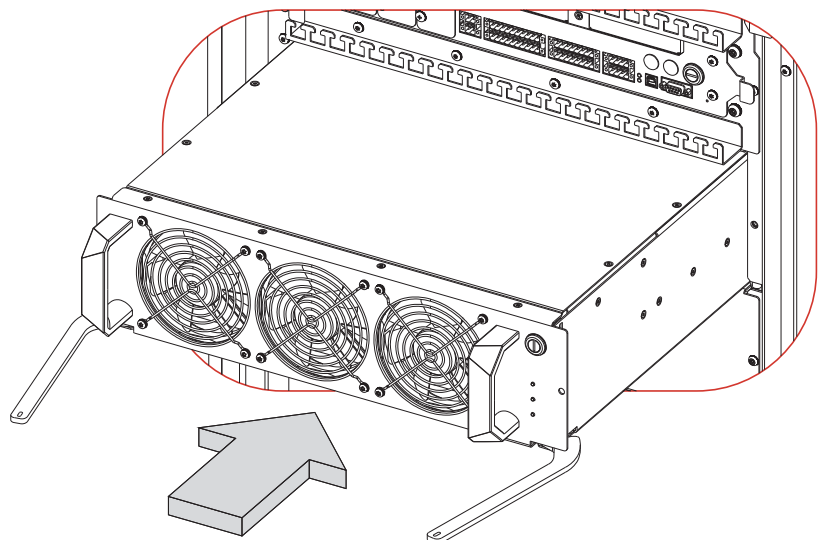

4. Close the levers to insert the BM until the end as shown in the figure.

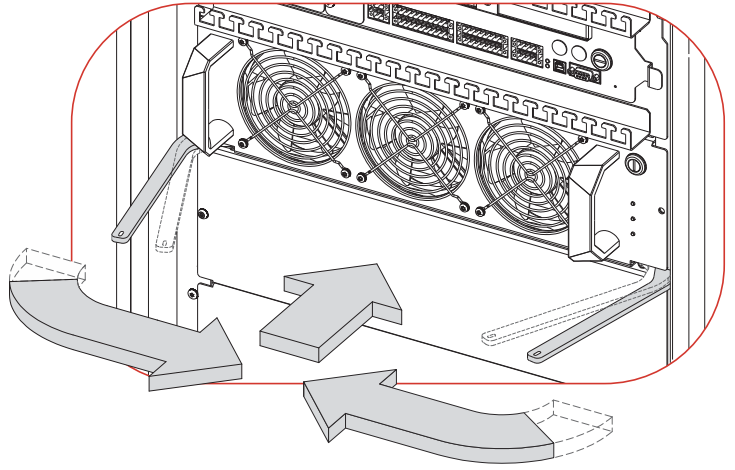

5. Fasten the BM using the supplied screws.

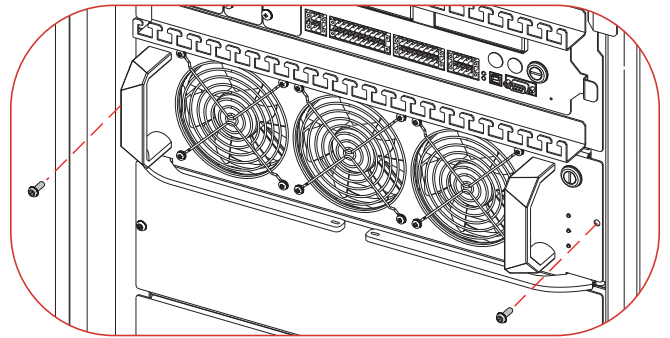

6. Turn the Switch Lock 90° clockwise to the closed position (see figure alongside).

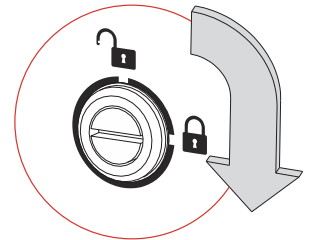

7.1 If the UPS is in **Service Bypass Mode** (Extraction Procedure 1.1 have been applied)

- a. Close the Input switch.
- b. Close the Bypass switch
- c. Close the Output switch.
- d. Close the Battery switch.
- e. Open the Manual Bypass switch.

7.2 If the UPS is in **ON Line Mode** (Extraction procedure 1.2 have been applied)

- a. Close the Bypass switch.

MAIN COMMUNICATION UNIT (MCU)

MCU WITH OPEN DOOR

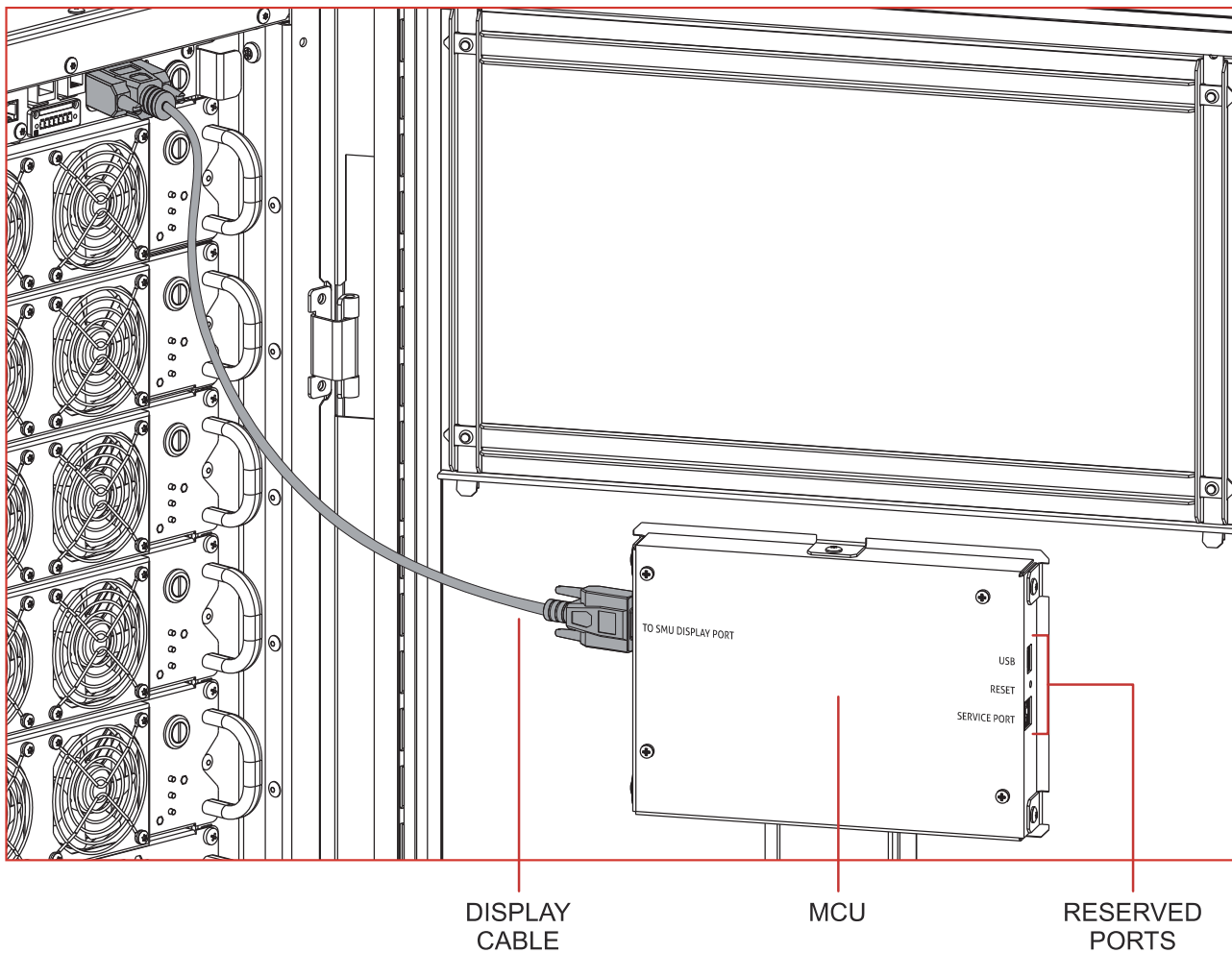

CONNECTIVITY PANEL (CP)

SYSTEM MONITORING UNIT (SMU)



ATTENTION: connect to the SMU only non-hazardous low voltage signals

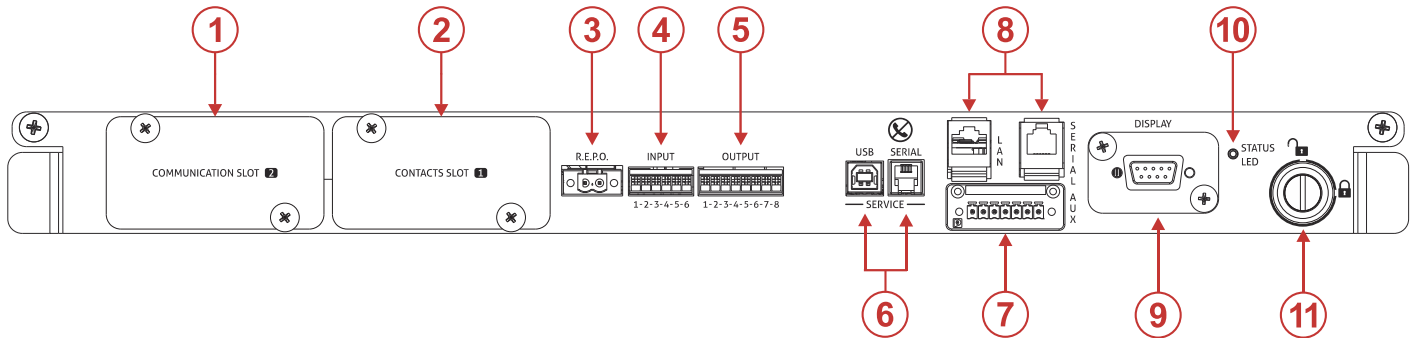

① Communication Slot (SLOT 2)

② Contacts Slot (SLOT 1)

③ R.E.P.O.

④ Signal input

⑤ Signal output

⑥ Service ports

⑦ Signal AUX

⑧ NETMAN port

⑨ Display port

⑩ SMU status LEDs

⑪ Switch Lock

PARALLEL INTERFACE BOARD (PIB) [OPTIONAL]

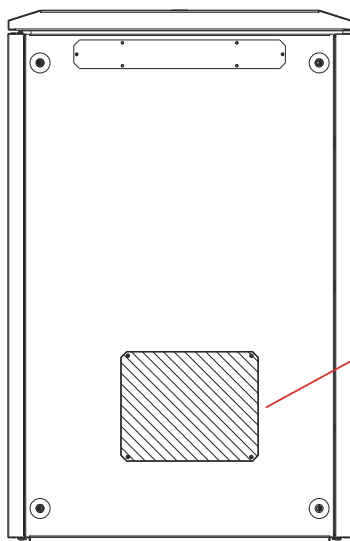

REAR
TOP VIEW

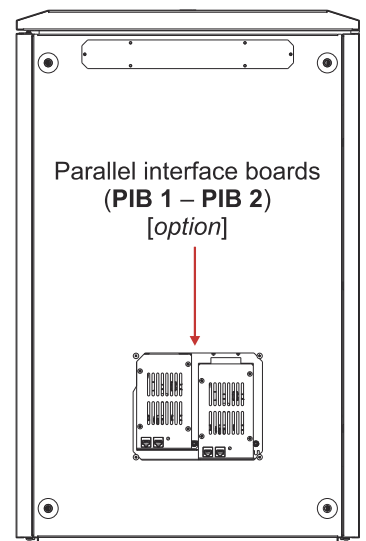
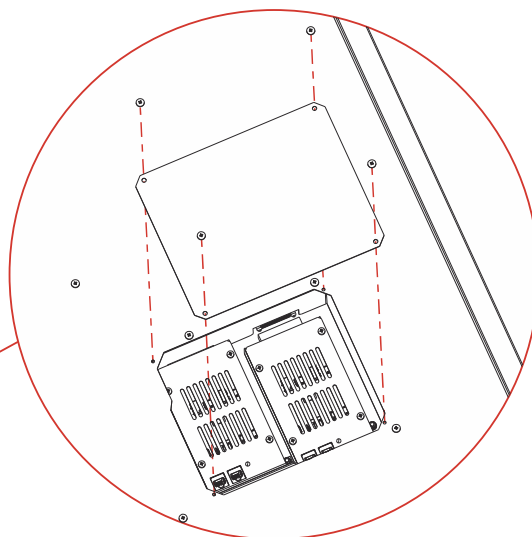

REAR
TOP VIEW

SMU (SYSTEM MONITORING UNIT)



The following operations must only be performed by skilled and specifically trained personnel.

Use Personal Protective Equipment (see "Important safety information" section).

When the SMU is not inserted, uncovered parts with dangerous voltage are present on the corresponding backplane.

ATTENTION: connect to the SMU only non-hazardous low voltage signals.



The SMU is pre-installed by the manufacturer. Remove the SMU only in case of maintenance or replacement.

Strictly comply with the instructions as listed below.

ATTENTION: when the SMU is extracted, the R.E.P.O. is disabled but only for the time necessary to insert a new SMU (60 minutes). If after 60 minutes the SMU has not been inserted, the system moves to Emergency Power OFF.

EXTRACTION

1. Turn the Switch Lock 90° counterclockwise to the open position  (see figure alongside).

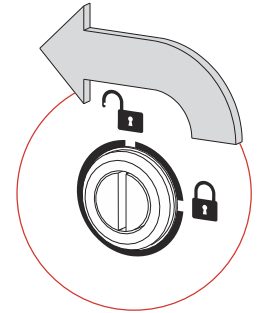

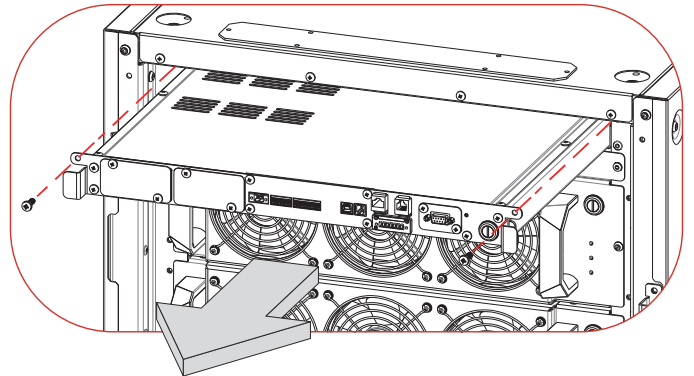

2. Remove the two side fastening screws and store them.
3. Using the handles, carefully pull and remove the SMU.



INSERTION

To insert the SMU into the cabinet, reverse the procedure described above. In brief:

1. Check that the Switch Lock is in open position .
2. Using the handles, carefully insert the SMU into the dedicated slot.
3. Fasten the SMU using the supplied screws.
4. Turn the Switch Lock 90° clockwise to the closed position .

COMMUNICATION INTERFACE - SMU



ATTENTION: this part is accessible and touchable, therefore connect only non-hazardous low voltage signals



R.E.P.O.

This isolated input is used to turn the UPS off remotely in case of an emergency. The UPS is supplied from the factory with two "Remote Emergency Power Off" (R.E.P.O.) inputs terminals short-circuited. If R.E.P.O. is to be installed, remove the pre-installed short-circuit and connect to the normally closed contact of the stop device using a double insulated cable (1 - 1.5 mm² with crimp terminal).

In case of emergency, by activating the stop device, the R.E.P.O. control is opened, and the UPS will shut-down and the load will be powered off completely.

The R.E.P.O. circuit is self-powered using a SELV type circuit. No external power supply voltage is therefore required. When it is closed (normal condition), a maximum current of 15 mA is present.

NOTE: In case of more than one UPS is to be connected within the same R.E.P.O. system. Each UPS must be provided with its own dedicated separate set of contacts. Please refer to "Parallel UPSs Signal Connections" section for further details.

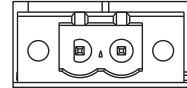

Connection wires: 2.5 mm² max (max cross section acceptable)

PROGRAMMABLE IN – OUT SIGNALS

The IN-OUT signals (refer to "System Monitoring Unit (SMU)") have a standard factory configuration. For further information refer to the "User Manual".

Moreover all the signals can be programmed using the service configuration software reserved to service personnel only.

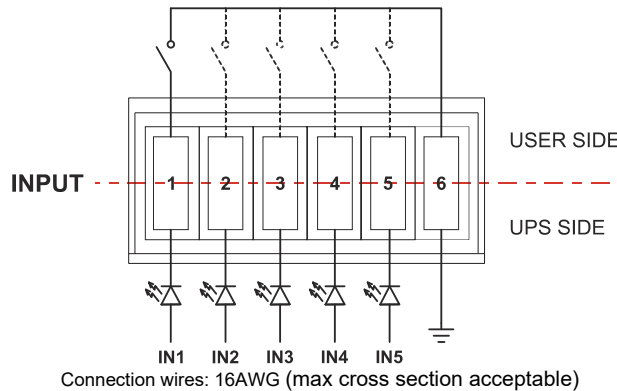

FACTORY DEFAULT SETTING

INPUT	FUNCTION
IN 1 #	Not programmed
IN 2 #	Auxiliary of CB OFF (N.C.) By connecting pins 2 and 6 to a normally open contact, when the contact is closed the UPS battery charger is disabled.
IN 3 #	Auxiliary of Battery test (N.C.) By connecting pins 3 and 6 to a normally open contact, when the contact is closed the UPS battery test is disabled.
IN 4 #	Auxiliary of External Battery Breaker (N.C.) Indication of External Battery Breaker position via the auxiliary contact (auxiliary contact of the external battery breaker). Connect pin 4 and 6 together via an external normally open contact. CONTACT CLOSED → SWBATT OPEN CONTACT OPEN → SWBATT CLOSED The UPS will receive information in relation to the status of the external battery breaker.
IN 5 #	Auxiliary of External Manual Bypass Switch (N.O.) Indication of External Manual Bypass Switch position via the auxiliary contact (auxiliary contact of the external manual bypass switch). Connect pin 5 and 6 together via an external normally closed contact. CONTACT CLOSED → SWMB OPEN CONTACT OPEN → SWMB CLOSED When the connection is opened the UPS will receive a manual bypass command. Note: if it's not used, the jumper must remain fitted

These inputs must be enabled from the display panel

NOTE: In case of an external maintenance bypass or Battery Cabinet installation, the relative switch auxiliary contacts must be connected to these inputs and programmed.

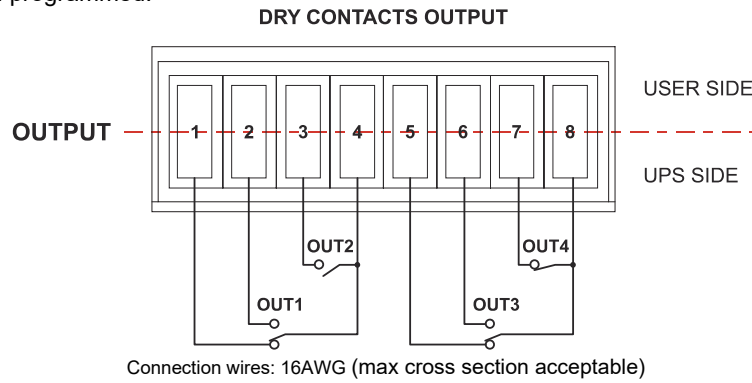

FACTORY DEFAULT SETTING:

OUTPUT	FUNCTION
OUT 1	Load on Bypass
OUT 2	Battery working
OUT 3	Battery low
OUT 4	Fault or Lock (F+L)

The output dry contacts are rated to:
1A @ 24Vdc or 1A @ 30Vac

AUXILIARY SIGNALS

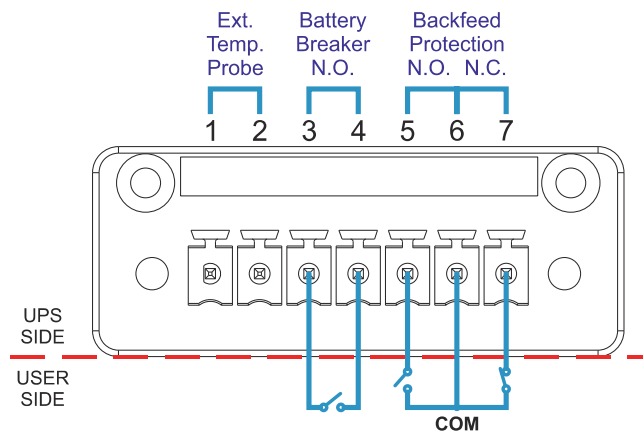

Insulated auxiliary signals:

EXTERNAL TEMPERATURE PROBE

Input to connect the external probe to measure the battery temperature. Please refer to the optional kit.

EXTERNAL BATTERY BREAKER

Output (default N.O.) for controlling the external battery breaker trip. The contact closes upon pressing the remote EPO or in the event of other fault conditions.

This dry contact is rated for: 1A @ 24Vdc or 1A @ 30Vac.

BACKFEED PROTECTION

Output (N.O. or N.C.) to manage the opening of an external disconnector switch in case of a backfeed fault occurs.

This dry contact is rated to: 1A @ 24Vdc or 1A @ 30Vac.

USB AND SERIAL (SERVICE PORT)

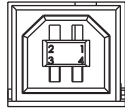

USB

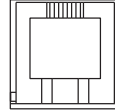

SERIAL RS232

Use these ports to connect the UPS to a server or PC for remote monitoring, service configuration or firmware update.

These two ports cannot be used simultaneously. The USB port is to be used as an alternative to the RS232 serial port. USB port function is only guaranteed with a cable length of no more than 1.5m. Where a longer cable is required it is recommended that the RS232 serial interface is used.

COMMUNICATION SLOTS

The UPS is provided with three communication slots which can be used to host optional communications cards. The slots are not interchangeable.

SLOT 1 –Contacts Slot

Slot hosting the contact/relay expansion card.

SLOT 2 - Communication Slot

Slot hosting the additional communication card (default configuration).

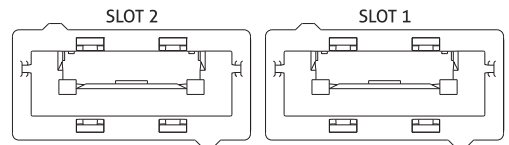

Please refer to the related manual for further information.

DISPLAY PORT

Use this port to connect the DISPLAY CABLE.

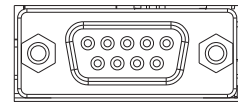

DISPLAY

SYSTEM INSTALLATION



WARNING!

IN A PARALLEL SYSTEM IT IS MANDATORY TO ONLY CONNECT UPSs OF THE SAME TYPE.

IT IS NOT POSSIBLE TO CONNECT UPSs WITH DIFFERENT TYPES OF BYPASS MODULES IN PARALLEL.

IT IS NOT POSSIBLE TO CONNECT UPSs WITH DIFFERENT TYPES OF POWER MODULES IN PARALLEL.

CABLES LENGTH INFORMATION

A MAXIMUM NUMBER OF 4 UPSs IS PERMITTED IN A PARALLEL SYSTEM.

IN ORDER TO CHOOSE THE CABLE SECTION FOR EACH UPS, REFER TO THE SECTION "POWER CONNECTION INFORMATION".

- CONNECT THE POWER L1, L2, L3 AND N TO THE INPUT TERMINALS IN1, IN2, IN3 AND N OF EACH UPS.
- CONNECT THE LOAD CABLES L1, L2, L3 AND N TO THE OUTPUT TERMINALS OUT1, OUT2, OUT3 AND N OF EACH UPS.

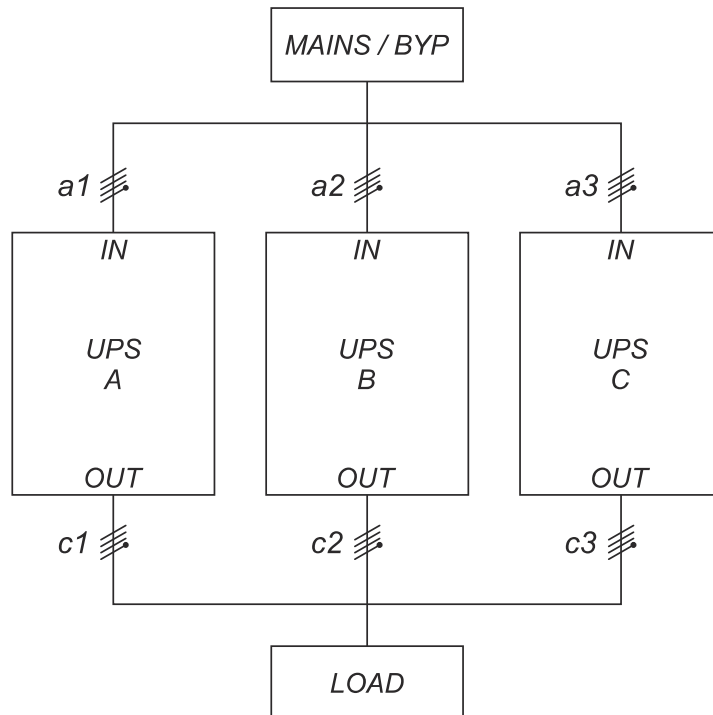

Example of parallel connection of three UPSs

INPUT TERMINALS:	IN
OUTPUT TERMINALS:	OUT
INPUT CABLES LENGTH:	a1, a2, a3
OUTPUT CABLES LENGTH:	c1, c2, c3

WHEN CONNECTING POWER TO THE UPSs THE INSTRUCTIONS BELOW MUST BE FOLLOWED TO ENSURE A GOOD LOAD SHARE WHEN OPERATING FROM BYPASS:

- SUPPLY CABLE LENGTHS MUST BE EQUAL: $a1 = a2 = a3$
- OUTPUT CABLE LENGTHS MUST BE EQUAL: $c1 = c2 = c3$
- $a1, a2, a3, c1, c2, c3$ MUST HAVE A MINIMUM LENGTH GREATER THAN 3m.

SYSTEM PROTECTION INFORMATION



WARNING

IN CASE OF PARALLEL SYSTEM, IT IS HIGHLY RECOMMENDED TO LOCK THE MANUAL BYPASS SWITCH (SWMB) OF EACH UPS IN ITS OPEN POSITION AND INSTALL A SINGLE "EXTERNAL MANUAL BYPASS SWITCH".

IF THE "EXTERNAL MANUAL BYPASS SWITCH" IS NOT INSTALLED, THE MANUAL BYPASS OPERATION SHALL BE CARRIED OUT QUICKLY CLOSING/OPENING ONE BY ONE ALL THE MANUAL BYPASS SWITCHES ON EACH UPS

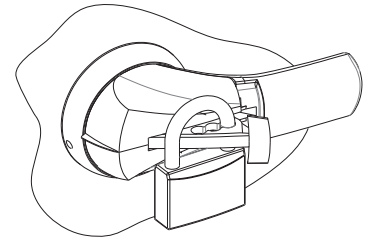

WARNING

IN CASE OF PARALLEL INSTALLATION EQUALISE THE NUMBER OF PM ON EACH UPS (\pm N.1 PM DIFFERENCE)

MAGNETO-THERMAL SWITCHES:

TO PREVENT A SYSTEM FAILURE FROM IMPACTING ALL OF THE UPSs PRESENT, IT IS MANDATORY TO PROTECT THE INPUT OF EACH UPS WITH AN INDIVIDUAL MAGNETO-THERMAL SWITCH. EACH ONE MUST BE INSTALLED UPSTREAM OF THE UPS (REFER TO THE CHAPTER "POWER CONNECTION INFORMATION" FOR SWITCHES SIZING).

DIFFERENTIAL SWITCH:

TO AVOID A FALSE DETECTION, ONE SINGLE DIFFERENTIAL SWITCH UPSTREAM OF THE ENTIRE SYSTEM MUST BE INSTALLED AS INDICATED IN THE FIGURE BELOW.

SPECIFICATIONS:

- DIFFERENTIAL CURRENT ADJUSTED TO THE SUM OF ALL UPSs + LOAD. IT'S STRONGLY RECOMMENDED TO MAINTAIN AN ADEQUATE MARGIN TO AVOID NUISANCE ACTUATION.
- TYPE B.
- DELAY GREATER THAN OR EQUAL TO 0,1s.

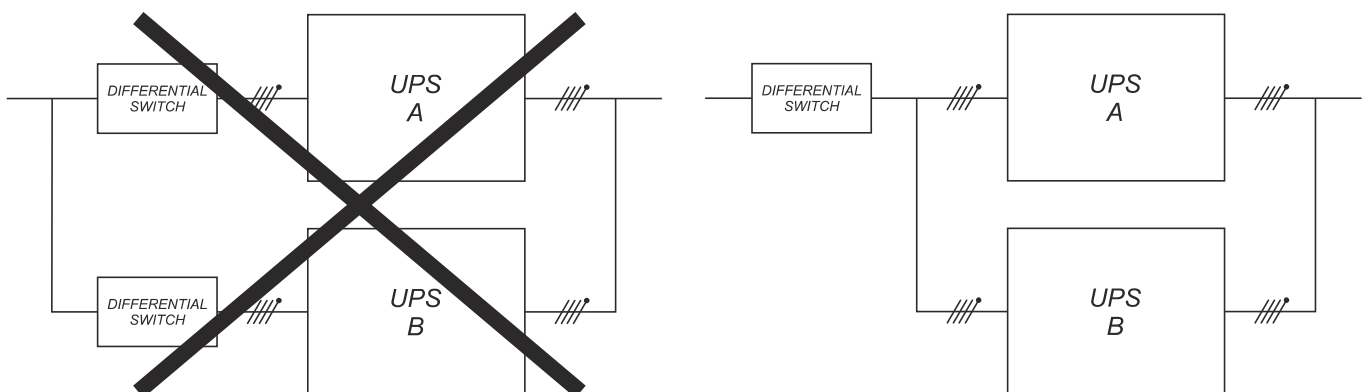

Example of parallel connection of two UPSs

PARALLEL UPSs POWER CONNECTIONS (COMMON/SEPARATED/PAIR)

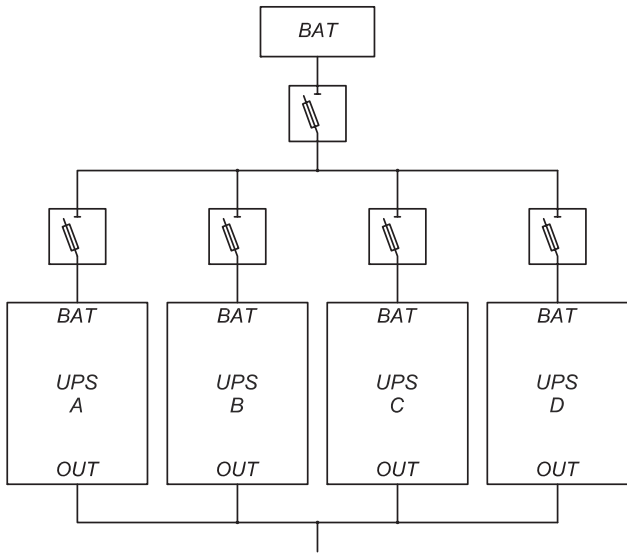

**COMMON BATTERIES
STAR CONNECTION ***

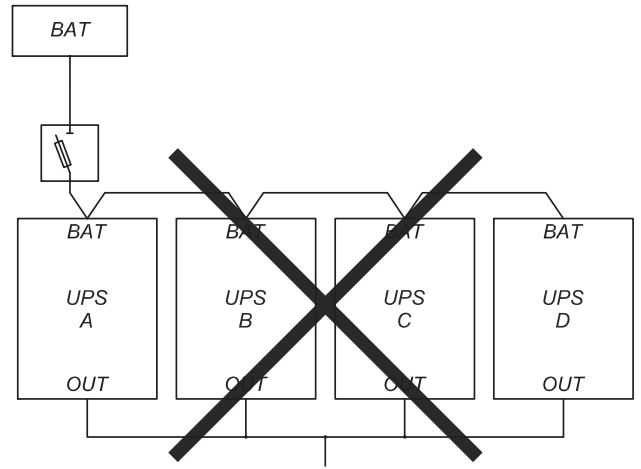

**COMMON BATTERIES
CASCADING CONNECTION IS NOT ALLOWED**

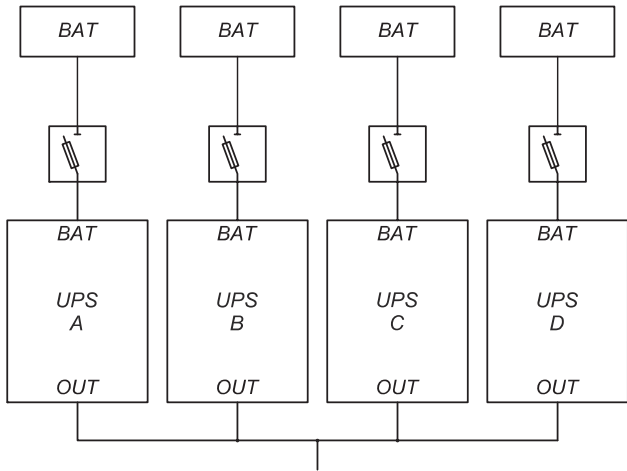

SEPARATED BATTERIES *

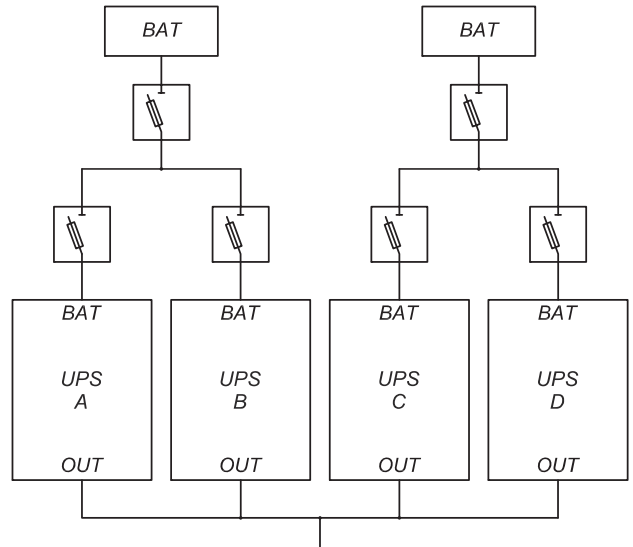

PAIR *

NOTE:

Examples with four UPSs

* The selected battery arrangement must be properly configured via the dedicated display menu in accordance with the instructions listed within the user manual.

PARALLEL UPSs SIGNAL CONNECTIONS (REPO/EXTTEMP/EXTSYNC)

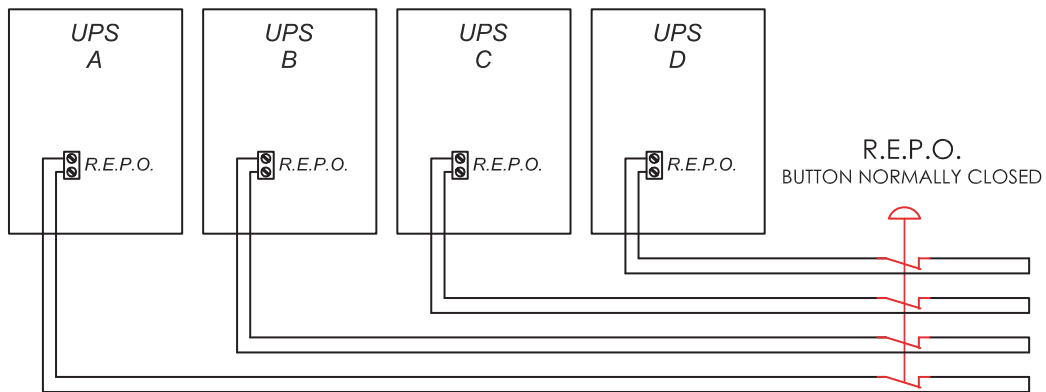

REMOTE EMERGENCY POWER OFF COMMAND (R.E.P.O.) CONNECTION:

TO CONTROL ANY UPSs WITH THE SAME EMERGENCY R.E.P.O. BUTTON, IN THE CASE OF A PARALLEL SYSTEM, YOU MUST USE AN EMERGENCY BUTTON WITH AS MANY SEPARATE CONTACTS AS THERE ARE UPSs PRESENT WITHIN THE SYSTEM. EACH INDIVIDUAL CONTACT MUST BE CONNECTED TO THE TERMINAL AS SHOWN IN THE EXAMPLE. IT IS MANDATORY TO USE A NORMALLY CLOSE PUSHBUTTON AND A DOUBLE INSULATED CABLE WITH A CROSS SECTION OF 1,5mm².

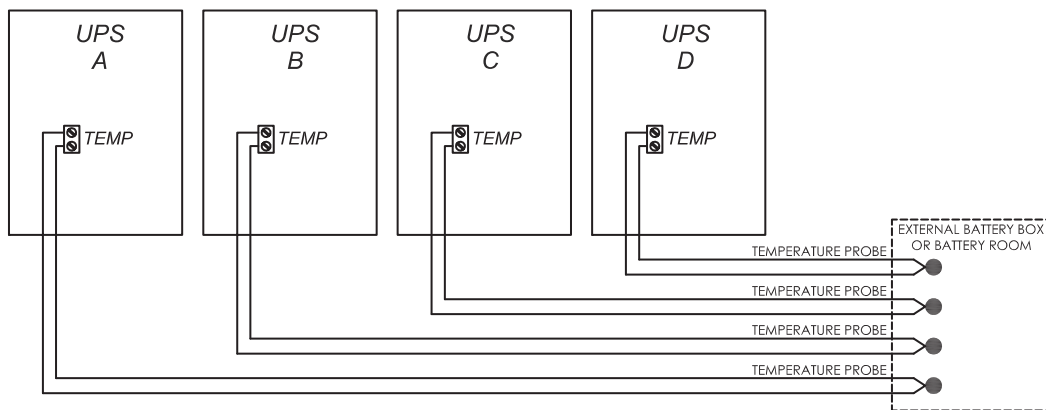

EXTERNAL TEMPERATURE PROBE (OPTIONAL):

WARNING! REFER TO RELATED MANUAL TO INSTALL THE EXTERNAL TEMPERATURE PROBE (MAXIMUM LENGTH 25 METERS). THE SYSTEM ONLY CONSIDERS THE MAXIMUM TEMPERATURE MEASURED BETWEEN ALL SENSORS.

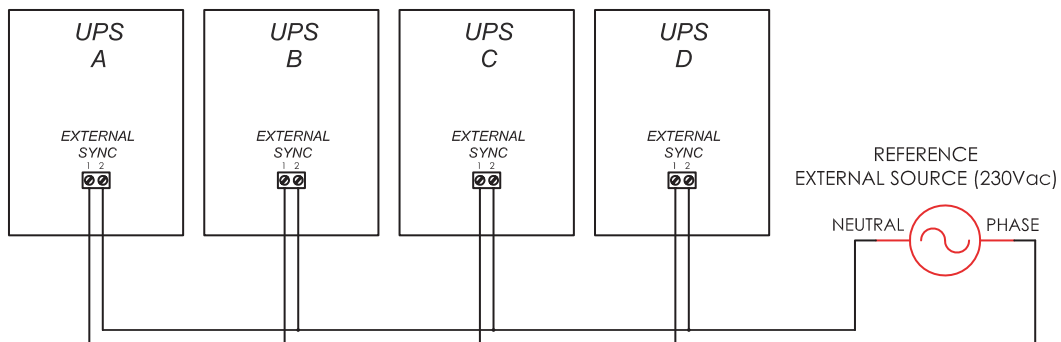

UPSs SYNCHRONISATION TO AN EXTERNAL SYNC SIGNAL:

THE UPSs ARE EQUIPPED WITH AN ISOLATED INPUT THAT CAN BE USED TO SYNCHRONISE THE INVERTERS TO A SYNC SIGNAL FROM AN EXTERNAL 230Vac SOURCE. IN CASE OF PARALLEL SYSTEM, THE SYNC SIGNAL MUST BE CONNECTED ON EACH UPS INDIVIDUALLY. MAKE THE CONNECTION AS INDICATED IN THE EXAMPLE, PAYING ATTENTION TO THE SIGNAL POLARITY.

CONNECT THE 230Vac EXTERNAL SOURCE TO THE UPSs ACCORDING TO THE FIGURE BELOW USING A DOUBLE INSULATED CABLE WITH A CROSS SECTION OF 1,5mm² min.

BATTERY CABINET POWER CONNECTIONS

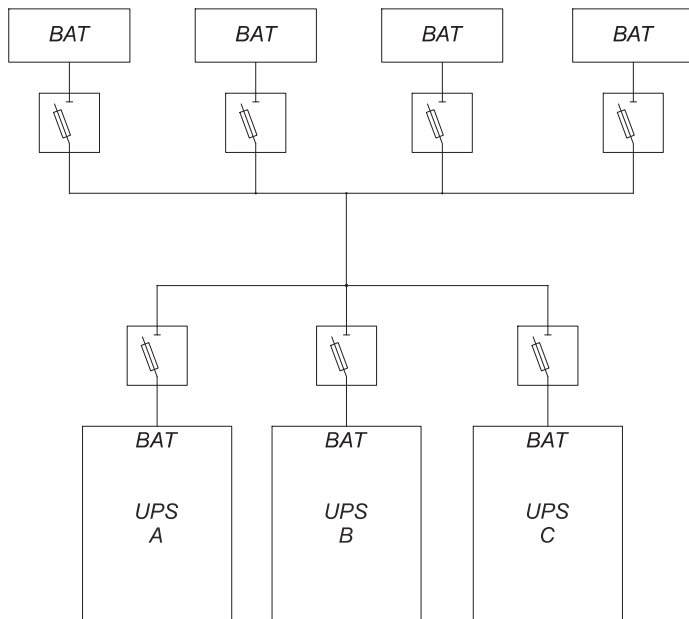

STAR CONNECTION

Example of connection of four battery cabinets and three UPSs.

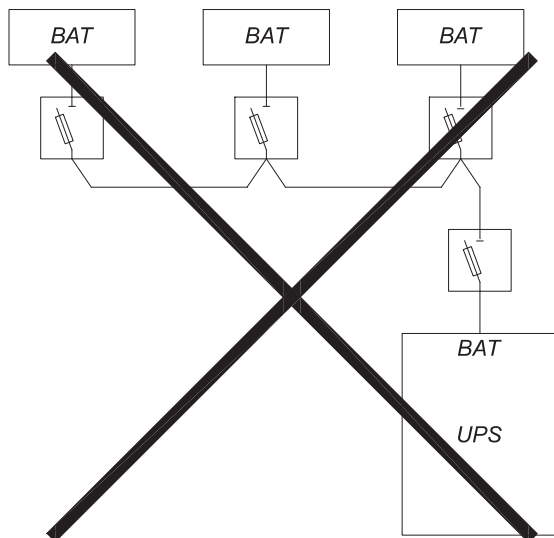

CASCADING CONNECTION IS NOT ALLOWED

Example of parallel connection of three battery cabinets

