

User manual

**MULTI POWER2**

**M2X - 15KW UP TO 120kW**

 **multipower**

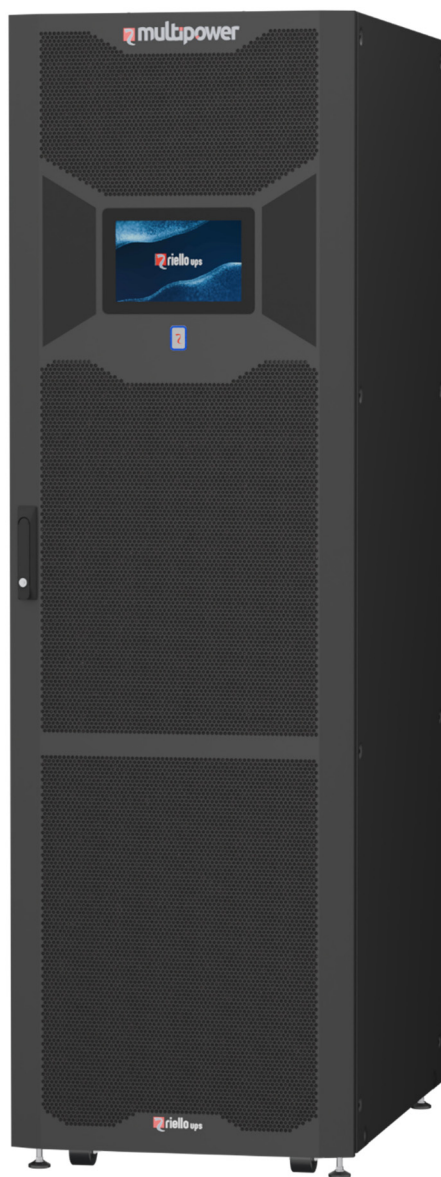

 **riello ups**



---

## INTRODUCTION

Thank you for choosing our product.

Our company is specialised in the design, development and manufacture of uninterruptible power supplies (UPS).

The UPS described in this manual is a high-quality product, carefully designed and manufactured to guarantee the best performance.

This manual provides detailed instructions for use and installation of the product.

**For information about using and to get the maximum performance from your UPS, this manual should be carefully kept near the UPS and READ IT BEFORE ANY OPERATION ON IT.**

**NOTE:** Some of the images in this document are provided as a guideline only, and they may not accurately reproduce the depicted product components.

---

## SAFETY PRECAUTIONS



Before carrying out any operation on the UPS it's mandatory to read the "Safety Manual".

For any installation and maintenance operations, refer to the Installation manual.







---

## ENVIRONMENTAL PROTECTION

While developing its products, the company spends great efforts in analysing environmental issues. All our products seek the objectives defined by the policies of the environmental management system, developed by the company according to the current legislation.

Hazardous materials such as CFCs, HCFCs or asbestos have not been used in this product.

The packaging is made of RECYCLABLE MATERIAL. Please dispose of the individual elements according to the current legislation in force in the country where the product is to be employed. Please refer to the following table for identifying the materials:

<b>DESCRIPTION</b>	<b>MATERIAL</b>	
Pallet	Wood (FOR)	
Packaging box	Corrugated cardboard (PAP)	
Protective bag	High Density Polyethylene (PE-HD)	
Adhesive buffers	Low Density Polyethylene (PE-LD)	
Bubble Cushioning Wrap		

---

## DISPOSAL OF THE PRODUCT

The UPS contains materials which (in case of decommissioning/disposal) are considered TOXIC and DANGEROUS WASTE, for example circuit boards and batteries. Treat such material according to the current legislation by using licensed centres. Their correct disposal helps to protect the environment and human health.

- © The reproduction of any part of this manual, even if partial, is forbidden unless authorised by the manufacturer.  
The manufacturer reserves the right to change the product described at any time without prior notice for improvement purposes.

---

# INDEX

<b>PRESENTATION</b>	<b>6</b>
<b>MULTI POWER2 15kW UP TO 120kW</b>	<b>6</b>
<b>M2X 120 CBC 6</b>	<b>7</b>
<b>M2X 120 PCS</b>	<b>11</b>
<b>OPERATING MODE</b>	<b>15</b>
<b>MODULAR UPS SYSTEM</b>	<b>15</b>
<b>ONLINE MODE</b>	<b>15</b>
<b>BATTERY MODE</b>	<b>15</b>
<b>AUTOMATIC STATIC BYPASS MODE</b>	<b>15</b>
<b>ECO MODE</b>	<b>15</b>
<b>FREQUENCY CONVERTER MODE</b>	<b>15</b>
<b>SMART ACTIVE MODE</b>	<b>15</b>
<b>EFFICIENCY CONTROL MODE (ECM)</b>	<b>15</b>
<b>MANUAL BYPASS MODE</b>	<b>16</b>
<b>SYSTEM ON COMMAND VIA BATTERY (COLD START)</b>	<b>17</b>
<b>MODULES AND UNITS</b>	<b>18</b>
<b>POWER MODULE (PM)</b>	<b>18</b>
<b>INTERFACE PANEL</b>	<b>19</b>
<b>BYPASS MODULE 200AMP (BM)</b>	<b>20</b>
<b>INTERFACE PANEL</b>	<b>21</b>
<b>MAIN COMMUNICATION UNIT (MCU)</b>	<b>22</b>
<b>CONNECTIVITY PANEL (CP)</b>	<b>22</b>
<b>SMU (SYSTEM MONITORING UNIT)</b>	<b>23</b>
<b>INTERFACE PANEL</b>	<b>23</b>
<b>PIB (PARALLEL INTERFACE BOARD) [OPTION]</b>	<b>24</b>
<b>INTERFACE PANEL</b>	<b>24</b>
<b>DISPLAY</b>	<b>25</b>
<b>DISPLAY OVERVIEW</b>	<b>26</b>
<b>STATUS BAR</b>	<b>26</b>
<b>ICONS, SYMBOLS AND TEXTS</b>	<b>26</b>
<b>MAIN DIAGRAM</b>	<b>26</b>
<b>ACTIVE TEXT AREAS</b>	<b>27</b>
<b>UPSs LIST</b>	<b>27</b>
<b>MENU</b>	<b>27</b>
<b>SLIDE SWITCHES STATUS</b>	<b>27</b>
<b>LOAD LEVEL AND REDUNDANCY SYSTEM STATUS</b>	<b>28</b>
<b>SECTION 1 - SYSTEM</b>	<b>29</b>
<b>SYSTEM MEASUREMENTS</b>	<b>31</b>
<b>SYSTEM STATUS</b>	<b>32</b>
<b>MENU ENTRIES</b>	<b>32</b>
<b>NOTIFICATION/ALARM</b>	<b>33</b>
<b>ACCESS LEVEL SELECTION</b>	<b>34</b>
<b>GLOBAL SYSTEM INFORMATION</b>	<b>34</b>
<b>COMMAND PANEL</b>	<b>35</b>
<b>BATTERY TEST COMMAND</b>	<b>35</b>
<b>BYPASS UNFORCED/FORCED COMMAND</b>	<b>35</b>
<b>SETTINGS MENU</b>	<b>36</b>
<b>LANGUAGE CONFIGURATION</b>	<b>36</b>
<b>DATE AND TIME SETTING</b>	<b>36</b>
<b>SCHEDULED OPERATIONS SETTING</b>	<b>37</b>
<b>GENERAL SYSTEM SETTINGS</b>	<b>37</b>
<b>SYSTEM INFORMATION</b>	<b>37</b>
<b>CHANGE PASSWORD</b>	<b>37</b>
<b>USER INTERFACE SETTINGS</b>	<b>38</b>
<b>NOMINAL VALUES</b>	<b>38</b>
<b>UPS PARAMETERS</b>	<b>39</b>
<b>ADVANCED SYSTEMS CONFIGURATIONS</b>	<b>39</b>

SYSTEM CONFIGURATION	40
BATTERY UNITE CONFIGURATION	40
BATTERIES CONFIGURATION	40
SYSTEM POWER SETUP	41
<b>SECTION 2 - UPS</b>	<b>42</b>
"UPS STATUS" TAB	42
"HISTORY ALARM" TAB	43
UPS/MODULE STATUS	44
"UPS SYNOPTIC" TAB	45
"SENSORS" TAB	46
"ALARM LIST" TAB	46
"FIRMWARE/SERIAL NUMBER" TAB	47
<b>SECTION 3 – MODULES</b>	<b>48</b>
POWER MODULE (PM) PAGE	48
"PM STATUS" TAB	48
"ALARM LIST AND INFO" TAB	49
BYPASS MODULE (BM) PAGE	49
"BM ELECTRICAL VALUES" TAB	49
"ALARM LIST" TAB	49
SYSTEM MONITORING UNIT (SMU) PAGE	50
"EXTERNAL I/O" TAB	50
"SENSORS" TAB	50
"ALARM LIST" TAB	50
<b>OPERATIVE PROCEDURES</b>	<b>51</b>
SYSTEM ON COMMAND	51
A. SYSTEM ON: DIRECT COMMAND	51
B. SYSTEM ON: VIA STATIC BYPASS	53
SWITCHING THE SYSTEM TO MANUAL BYPASS	55
SWITCHING THE SYSTEM FROM MANUAL BYPASS TO NORMAL OPERATION	56
<b>STATUS / ALARM CODES</b>	<b>57</b>
UPS	57
STATUSES	57
COMMANDS	58
WARNING	58
ANOMALIES	59
FAULTS	60
LOCKS	61
PM	62
STATUSES	62
COMMANDS	62
WARNING	63
ANOMALIES	63
FAULTS	64
LOCKS	65
<b>TECHNICAL DATA TABLE</b>	<b>66</b>

## MULTI POWER2 15kW UP TO 120kW

Riello UPS Multi Power2 is the evolution of our modular UPS range.

It is designed to offer higher performances, increased power scalability, simpler integration to both existing and new systems and above all enhanced operating efficiency and global flexibility to reduce both the upfront investment and the day-to-day operational costs.

Thanks to 10-inch colour touchscreen display you can easily and quickly access key information, operating conditions and main measurements of the entire system or a single power module.

With its unmatched power density, Multi Power2 minimizes the space requirements. MultiPower2 is compatible both two types of power module (PM): a 15 kW Power Module that uses the state-of-the-art IGBT components (M2X 15 PM) or a 15 and 30 kW Power Modules designed with the latest and most innovative Silicon Carbide technology (M2X 15 PM BLUE – M2X 30 PM BLUE), which are able to reach outstanding efficiency in online mode.

Power scalability can be achieved by adding up to 5 power modules per cabinet and, in parallel operations, the overall power can reach 480 kW.

The Power Modules are fully independent, hot-swappable and plug-in; they ensure full protection of the load in on-line double conversion during system extension or maintenance.

Multi Power2 is the most compact, sustainable and reliable solution that guarantees quality power supply to the most demanding applications.

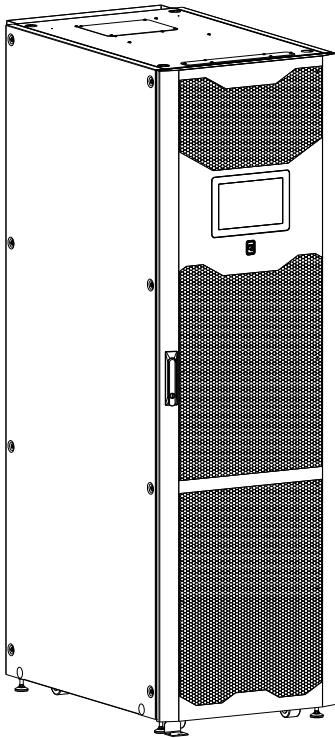

M2X 120 CBC 6

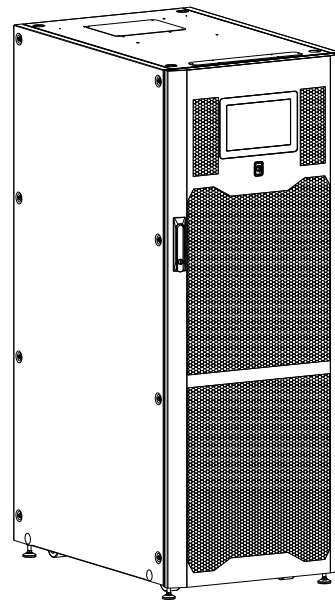

M2X 120 PCS

In the Multi Power2 range there are several types of modular UPS with power up to 120 kW in a single unit, which can contain up to 5 Power Modules (PM15-15 BLUE-30 BLUE) and one Bypass Module (BM).

PMs are connected in parallel in order to increase reliability in the supply of power to the load and the power available at the system output (ref. to the "Modules and Units" chapters)

The load that can be applied to a UPS can be higher than the load that can be sustained by each PM thanks to the automatic power-sharing. Increased reliability is only achieved on condition that the total system power, with one or more PMs deactivated, remains higher than the load required. This condition is always achieved by adding at least one redundant PM to the minimum number of elements required to power the load, so that after the automatic exclusion of a faulty PM, the power supply can continue in a correct manner.

Each PM is equipped with a smart control unit, connected through a data bus with the other PMs within the system, achieving a high reliability distributed logic.

**Note:** any redundancy of the PMs may be set-up during configuration.

The Bypass Module (BM) operates as the central AUTOMATIC BYPASS for the entire UPS (ref. to chapter "Modules and Units"). In order to further increase the power of the system, multiple Modular UPS can be connected in parallel, up to 4.

# M2X 120 CBC 6

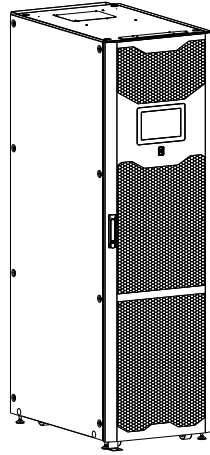

M2X 120 CBC 6 is an UPS with a maximum power of 120 kW which can contain up to 5 Power Modules (PM15-15 BLUE-30 BLUE) and one Bypass Module (BM). M2X 120 CBC 6 is provided by default with internal manual battery switch and with manual bypass switch, single input connection and rear cable entry.

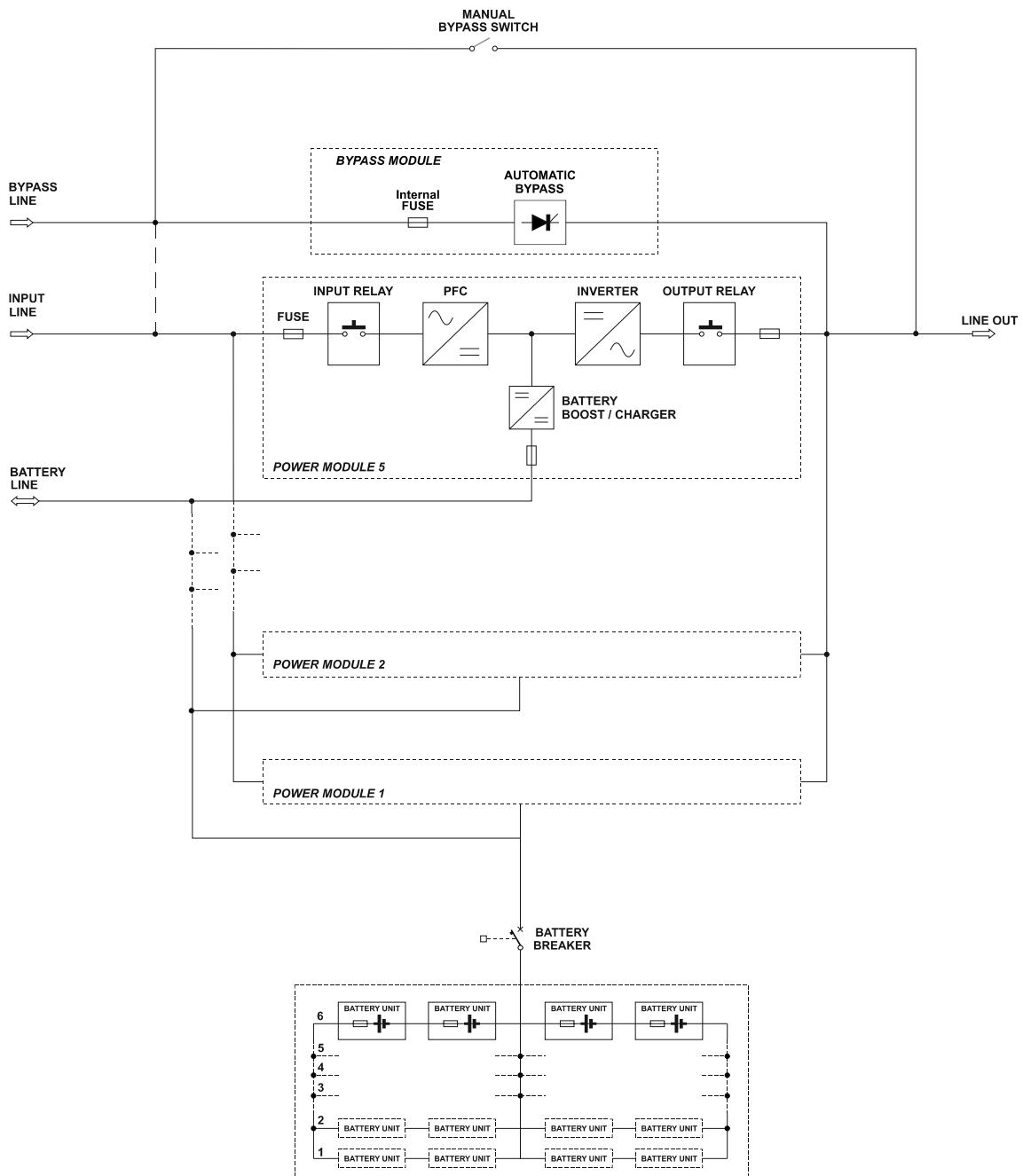

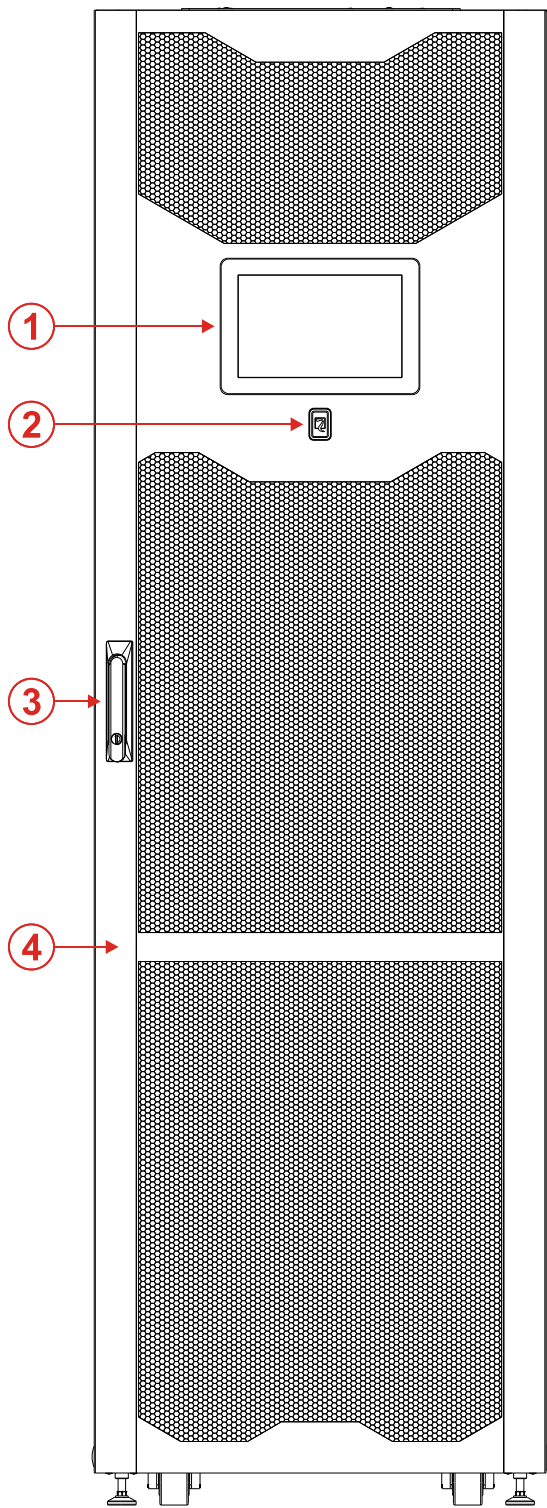

Front view

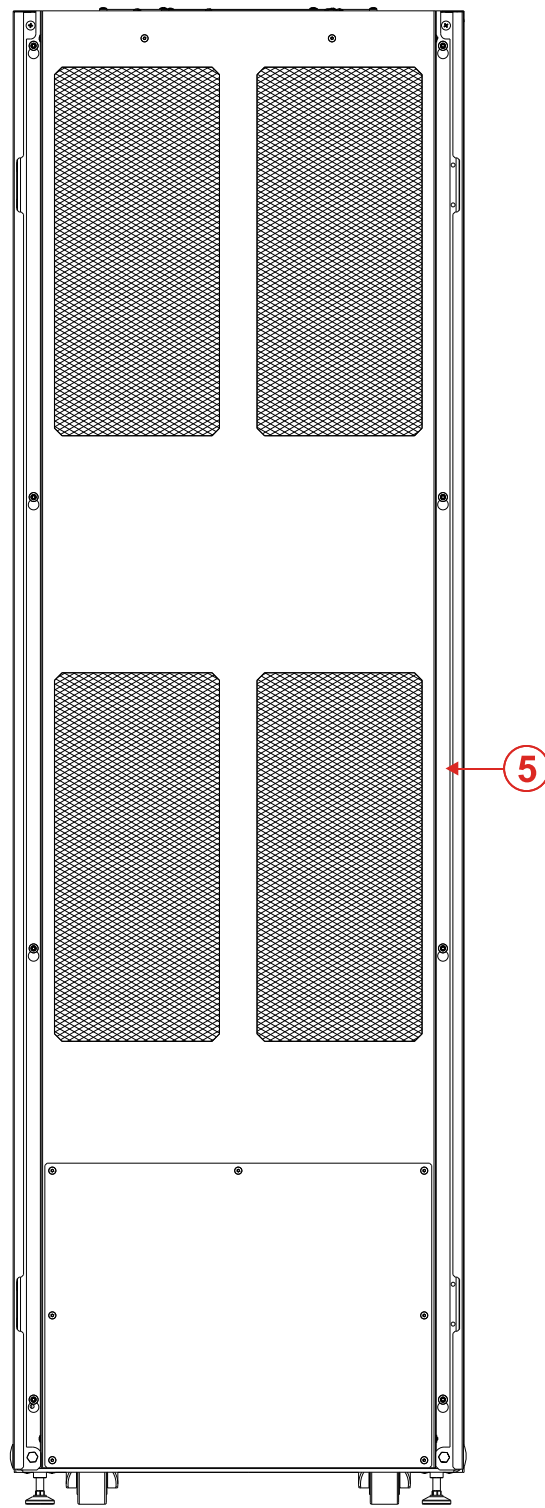

Rear view

- ① Frame
- ② UPS status LED
- ③ Handle with lock

- ④ Door
- ⑤ Back Panel

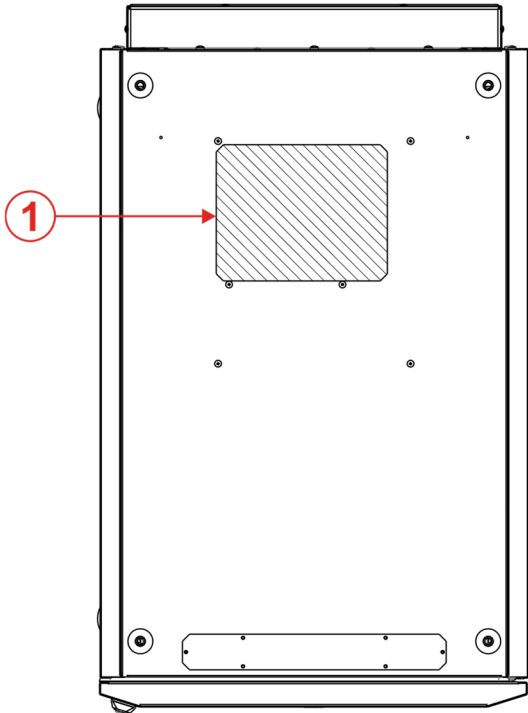

*Top view*

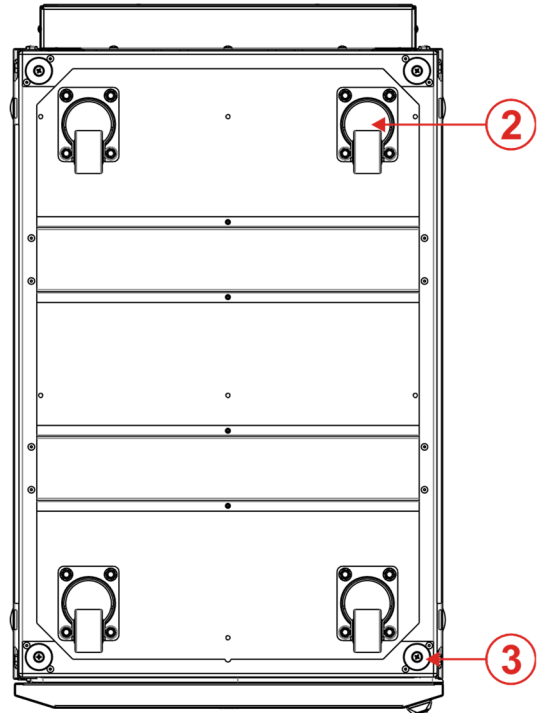

*Bottom view*

- ① PIB
- ② Swivel castors for positioning
- ③ Leveling stands

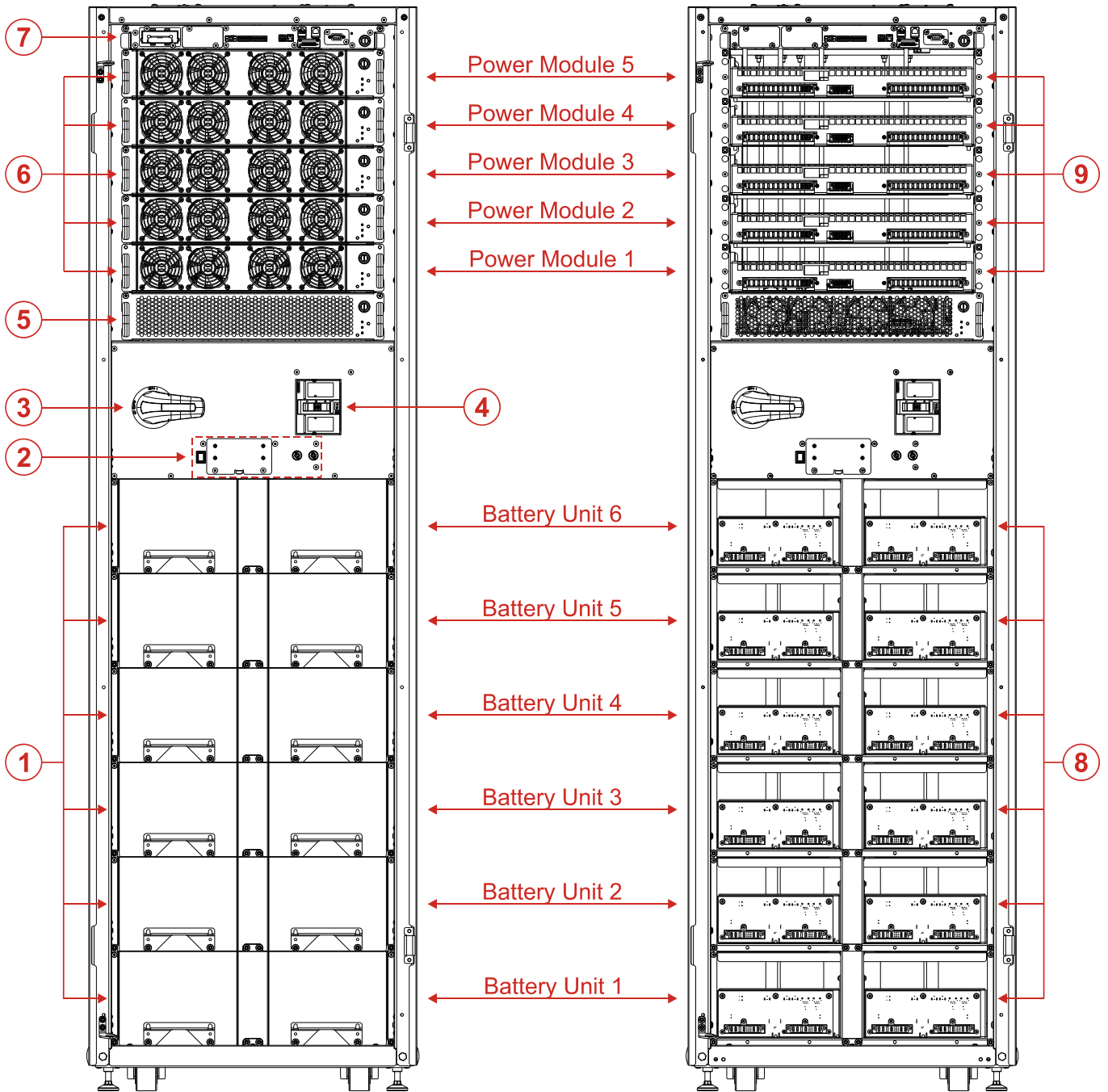

Front view - open door  
Power Modules inserted

Front view - open door  
Power Modules and Battery Unit extracted and  
respective blanking plates removed

- |  |   |
|--|---|
| <p>① Battery Section (BU)</p> <p>② Cold Start section (optional)</p> <p>③ Manual Bypass switch (SWMB)</p> <p>④ Battery switch (SWBATT)</p> <p>⑤ Bypass Module (BM)</p> | <p>⑥ Power Module (PM)</p> <p>⑦ Connectivity panel</p> <p>⑧ Battery backplane: batteries monitoring interface connections between BU and cabinet</p> <p>⑨ Backplane: power and communication interface connections between PM and cabinet</p> |
|--|---|

# M2X 120 PCS

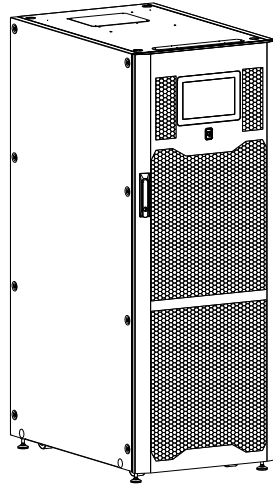

M2X 120 PCS is an UPS with a maximum power of 120 kW which can contain up to 5 Power Modules (PM15-15 BLUE-30 BLUE) and one Bypass Module (BM). M2X 120 CBC 6 is provided by default with main input switch, bypass switch, manual bypass switch and output switch, single input connection and bottom or rear cable entry.

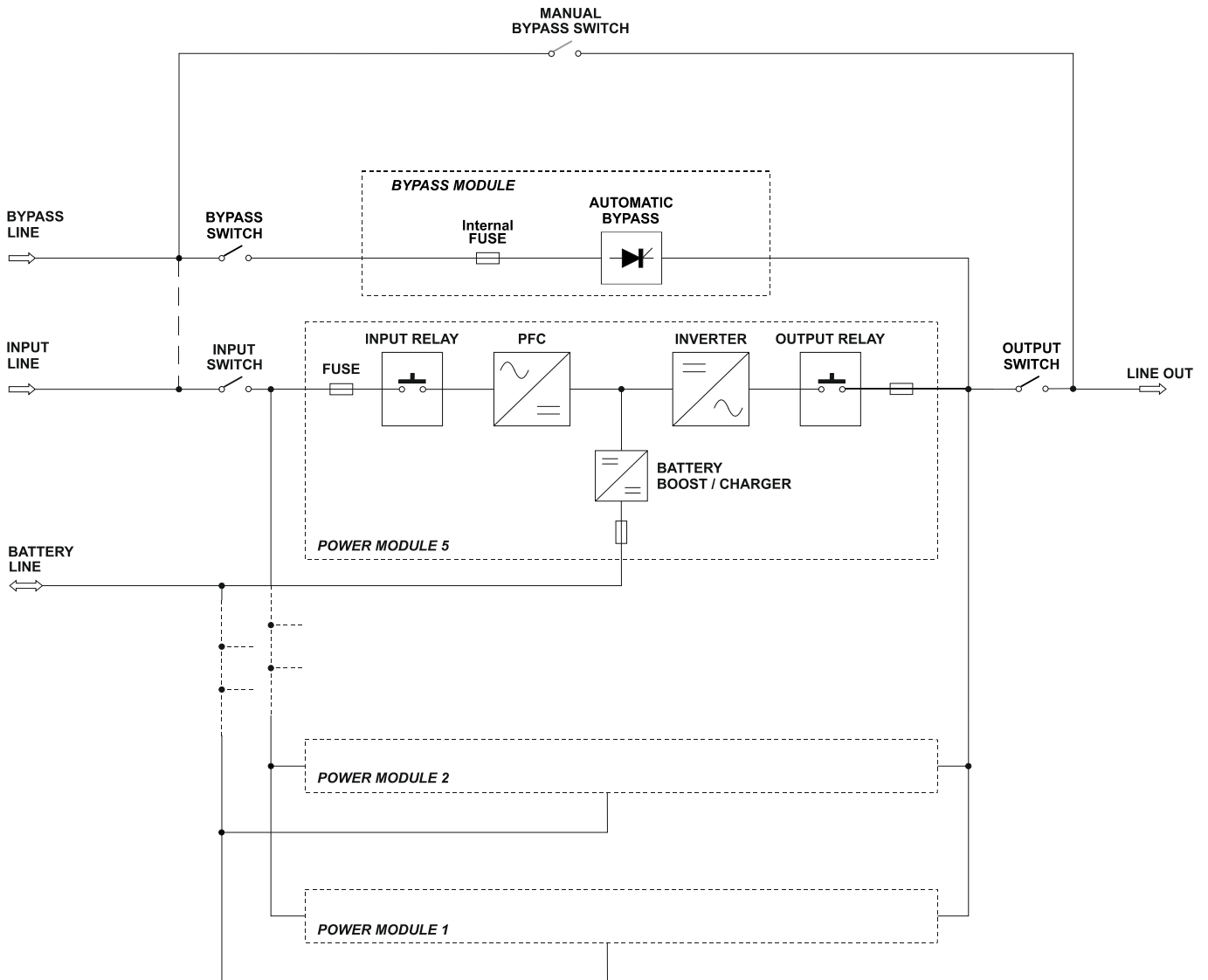

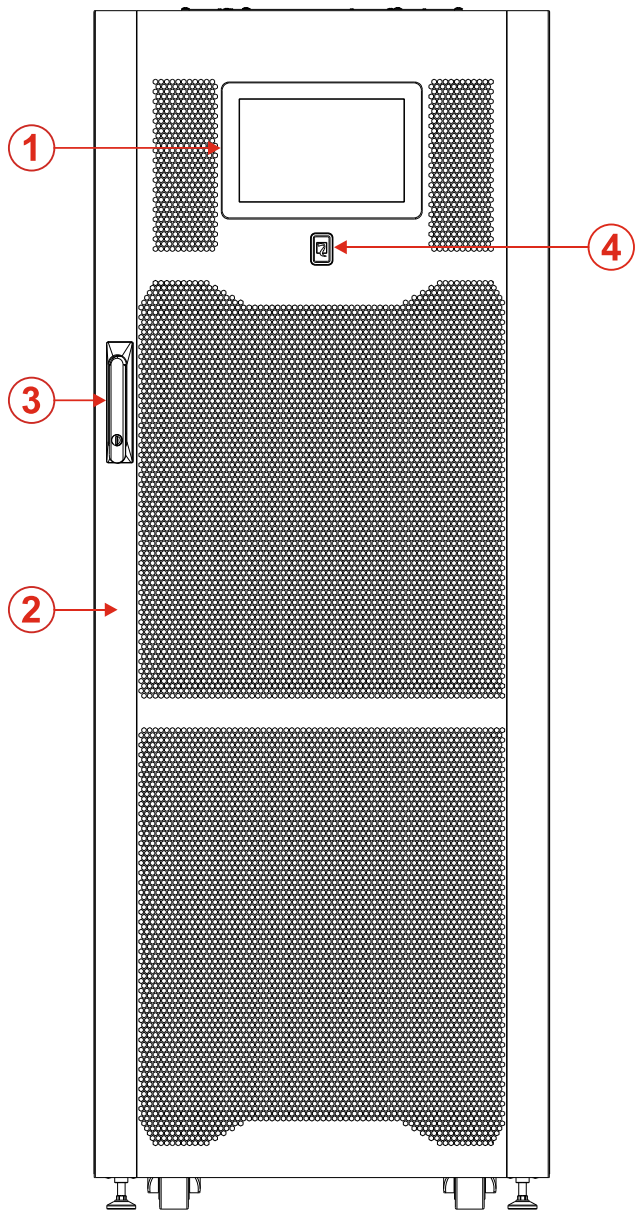

Front view

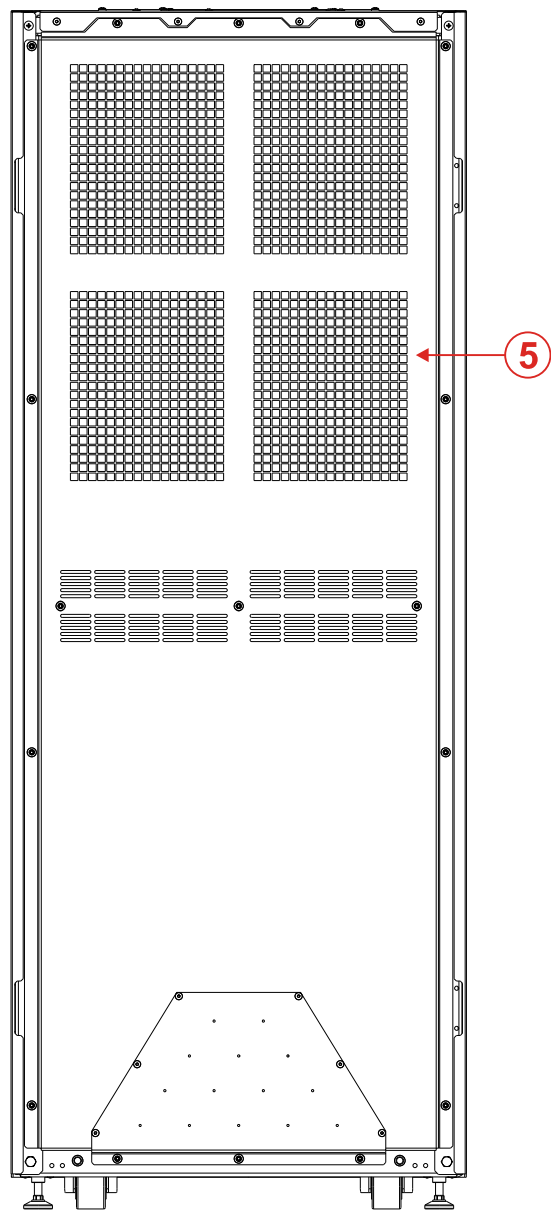

Rear view

① Frame

② Door

③ Handle with lock

④ UPS status LED

⑤ Back Panel

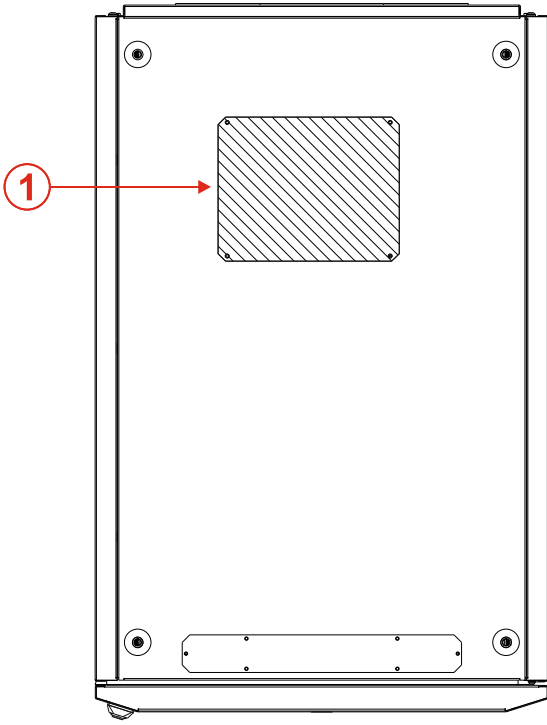

Top view

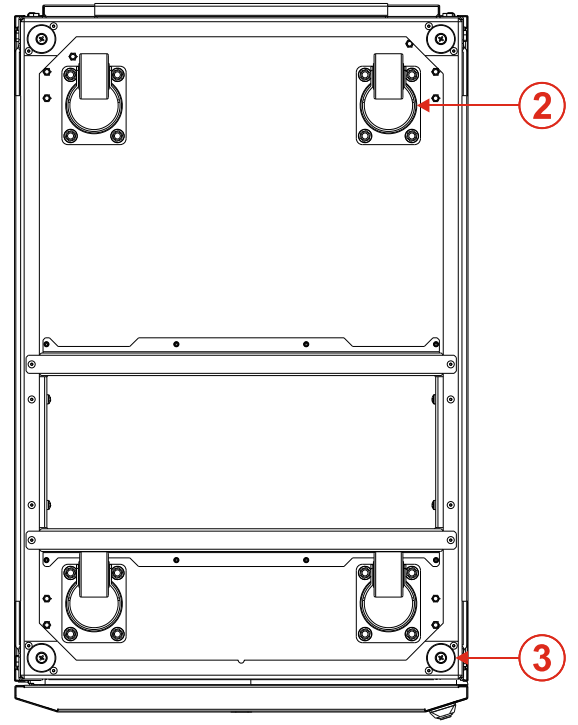

Bottom view

- ① PIB
- ② Swivel castors for positioning
- ③ Leveling stands

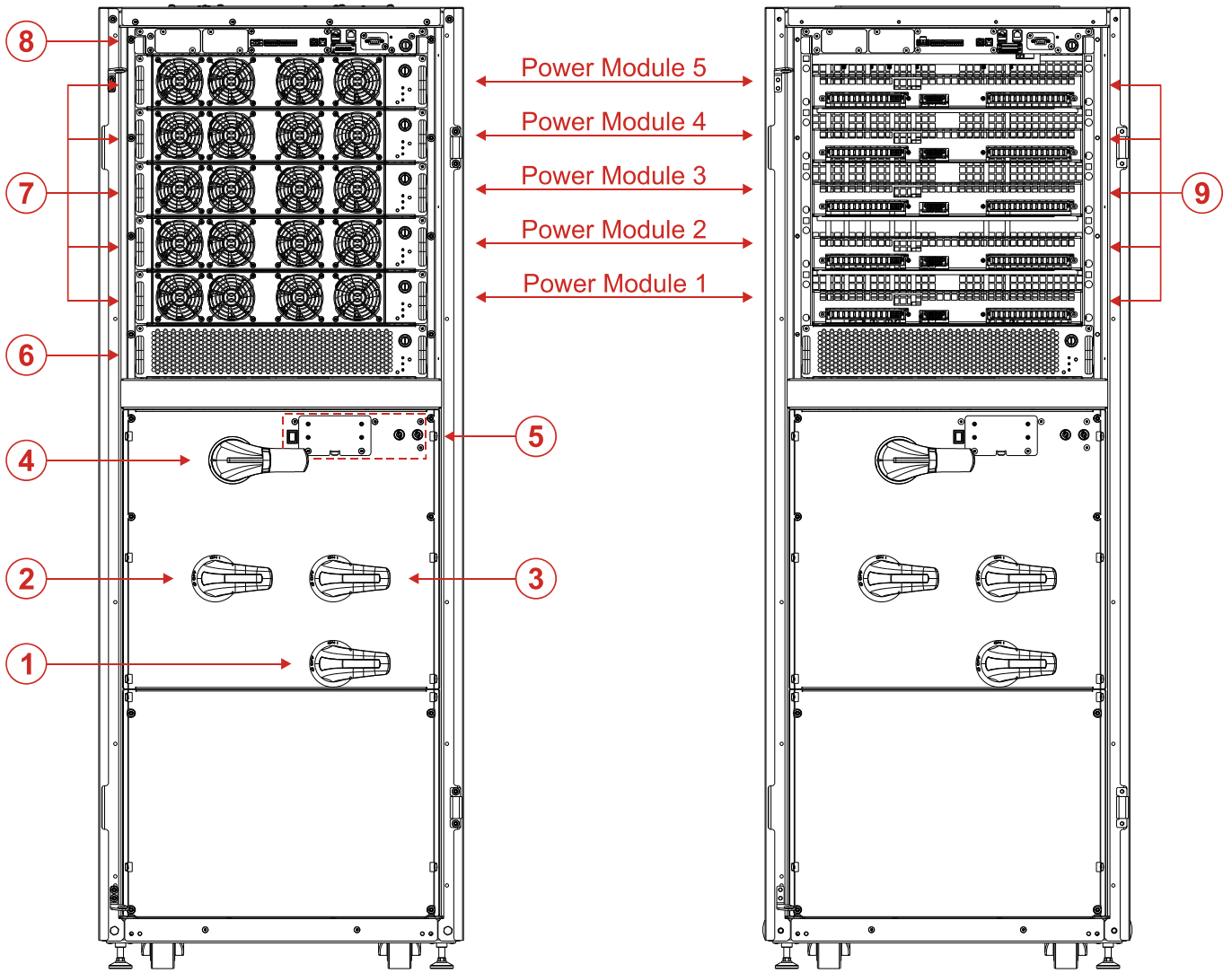

Front view - open door  
Power Modules inserted

Front view - open door  
Power Modules and Battery Unit extracted  
and respective blanking plates removed

- |  |  |
|--|--|
| <ul style="list-style-type: none"> <li>① Switch Bypass</li> <li>② Switch Out</li> <li>③ Manual Bypass switch (SWMB)</li> <li>④ Switch In</li> <li>⑤ Cold Start section (optional)</li> </ul> | <ul style="list-style-type: none"> <li>⑥ Bypass Module (BM)</li> <li>⑦ Power Module (PM)</li> <li>⑧ Connectivity panel</li> <li>⑨ Backplane: power and communication interface connections between PM and cabinet</li> </ul> |
|--|--|

# OPERATING MODE

## **MODULAR UPS SYSTEM**

Modular UPS Systems are intended to ensure a perfect voltage supply for the equipment connected to it, both with and without a power supply network. Once connected and powered, the system generates an alternating sinusoidal voltage, with stable amplitude and frequency, regardless of surges and/or variations affecting the electrical supply.

The elements of the Modular UPS System are designed and manufactured to be durable. However as with any electrical power system, they require regular maintenance. Furthermore, some of the components have, inevitably, a fixed life cycle and therefore they must be regularly checked and replaced, if the conditions require it, in particular batteries and fans.

It is therefore recommended that a preventative maintenance program is implemented and performed by specialized staff whom are approved and certified by the manufacturer.

Our Service Department is at your disposal for customizing preventative maintenance options to suit your requirements.

### **ONLINE MODE**

During ONLINE MODE the system operates in double conversion operation. This mode provides maximum protection for the load. During operation the energy coming from the electrical supply network (AC), is converted into a clean and stable output. The voltage supplied to the load is a perfect sinewave, with the frequency and voltage independent of the incoming mains supply (V.F.I. Voltage and Frequency Independent). During this mode, the batteries are constantly maintained in a charged condition.

### **BATTERY MODE**

When the AC power network falls outside the pre-set tolerances, for example, in case of a blackout or voltage or frequency interferences, the system automatically switches to the BATTERY MODE and takes power from the batteries to support the load. When the AC network is again clean and stable, the system returns back to the normal mode operation.

The Power Walk-In function can be activated through the configuration software. This function allows, upon reconnection to the network (following a supply failure), a progressive absorption of power from the incoming supply, in order to avoid stressing (due to the inrush current) a generator which is installed upstream, if fitted. The duration of the transition mode can be set between 1 to 120 seconds.). During the transition mode the required power is partially collected from the batteries and partially from the network keeping the sinusoidal take-up. The battery charger is switched on again when the transition mode ends.

### **AUTOMATIC STATIC BYPASS MODE**

During this operation mode, the UPS is forced to bypass and the load is directly powered by the AC supply, therefore, any input interference will directly affect the connected load.

### **ECO MODE**

In order to optimise efficiency, in ECO mode, the load is normally powered via bypass (any disturbances that occur in the network can have effects on the load). In the event of a mains power supply failure or if the power supply is not within the pre-set tolerances, the UPS will switch to normal ON LINE operation with double conversion. Approximately five minutes after the power supply returns within tolerance, the load is switched back to bypass. All these procedures can be only selected by authorized personnel.

### **FREQUENCY CONVERTER MODE**

The UPS can be configured in this mode to generate a fixed output frequency different from the input frequency. This configuration automatically disables the bypass line.

### **SMART ACTIVE MODE**

The UPS may be set in SMART ACTIVE mode during which, according to the statistical data of the quality of the mains power supply, the UPS will autonomously decide the most appropriate operating mode between ON LINE and ECO MODE.

### **EFFICIENCY CONTROL MODE (ECM)**

In case of very low load operations, the EFFICIENCY CONTROL mode improves the total system efficiency, while preserving the ON LINE mode and the set redundancy. The algorithm behind the ECM is designed to ensure that the active modules operate close to their maximum efficiency values (between 30 to 50%), monitor the variation of the load and equalize the hours worked by each PM to ensure that all electronic components age evenly and provide dynamic performances close to ONLINE mode. The PMs that are not required to support the applied load are placed in a low consumption state. In the event of a mains power supply failure or if the power supply is not within the specified conditions, all of the PMs switch to normal ON LINE operation with double conversion. If the load suddenly and significantly increases, the system could temporarily switch to the bypass line.

## MANUAL BYPASS MODE



**ATTENTION:** The SWMB disconnection switch installed on the UPS is not a maintenance bypass switch, therefore, there is dangerous voltage within the Cabinet, even if this disconnection switch is closed.



**CAUTION:** Contact a service center if any malfunctions are detected. Maintenance can be carried out only by skilled staff authorized by the manufacturer.

**CAUTION:** dangerous voltages can be present inside the device, even if the input, bypass, output and battery switches are open.

The removal of any enclosure panels from the Modular UPS Cabinet by non-skilled personnel is dangerous and may cause damage to the operator, to the equipment and to the loads connected to it.

Operation to be performed in order to switch the UPS to “Manual Bypass” (in system with only one cabinet).

**NOTE:** if the bypass line is not present, the manual bypass operation may cut off power to the load. With the maintenance bypass switch closed the bypass input line supplies the load directly. During this mode of operation, any disturbances or blackouts on the power supply line will directly affect the connected equipment.

The switching of the System to manual bypass can be done with the following procedure:

- Verify that the bypass voltages are correct on the “System Status” page.
- Verify that the inverters are synchronized to the bypass line (no presence of the message “Bypass not available”).
- Verify that the BM has no anomalies on the “System Status” page.
- From the “Commands” panel” page, slide “Bypass Unforced/Forced” from “O” to “I” to start the system to static bypass.
- Confirm "Bypass Forced command".
- Close the external maintenance bypass switch.
- The load is now supplied directly by the bypass line through the maintenance bypass switch.
- From the “Commands” panel page, slide “System: OFF/ON” from “I” to “O”.

**NOTE:** The maintenance bypass is an external switch, always verify the proper connection of the relative Auxiliary Contact.

Operation to be performed in order to switch the UPS from “Manual Bypass” to normal operation:

- From the “Commands” panel page, slide “System OFF/ON” from “O” to “I” to start the PMs (if not already on).
- Confirm “ON command”.
- This command will synchronize all of the PMs ready to start, but the system will remain on bypass.
- From the “Commands” panel page, slide “Bypass Unforced/Forced” from “O” to “I” to close static bypass.
- Confirm "Bypass Forced command".
- Verify the output Voltages on the “System Status” page.
- Open the maintenance bypass switch.
- Verify that no anomalies are present on the “System Status” page.
- Verify that all PMs are ready.
- Verify that all the measurements and the operational status are correct on the “System Status” page.
- From the “Commands” panel page, slide “Bypass Unforced/Forced” from “I” to “O”.
- Confirm "Bypass Unforced command" .
- The system will transfer the load from the bypass to the inverter output.
- Verify the output Voltages on the “System Status” page.
- From this point the system is in normal operation.
- Verify that all the measurements and the operational status are correct on the “System Status” page.

## **SYSTEM ON COMMAND VIA BATTERY (COLD START)**

For the COLD START button location, please refer to the “General views” chapter.

Note: Avoid turning on the system from battery if the battery charge status and/or the autonomy information are unknown

- Close the battery switch.
- Press the “Cold start” button and keep it pressed for at least 5 seconds.
- The system will turn on in the “STAND-BY WITH CB OFF” mode (The status led will light up and the display will start).

**NOTE:** if no actions are taken within one minute, the system will automatically shut down to avoid discharging the batteries.

- Verify that no anomalies are present on the status bar (except for the anomalies/faults “PM/PMs fault/lock or PM/PMs anomaly”, “Bypass not available”, “Bypass volt. out of range”, “Inverter asynchronous”)
- From the “Commands” panel page, press the “System: OFF/ON” from “O” to “I”.
- Confirm the “ON command”. The UPS will turn on.
- Verify the output voltages on the Output status page.
- The system is now in the BATTERY WORKING mode.
- To restore the UPS to ON LINE mode, the mains voltage must be present. The UPS will change to ON LINE mode and the batteries will begin to charge.

# MODULES AND UNITS

The cabinet consists of modules and units which allow quick maintenance and expandability of the system. The easy-to-swap parts are:

- Power Module (PM)
- Bypass Module (BM)
- Connectivity Panel (CP)
  - System Monitoring Unit (SMU)
  - Parallel Interface Board (PIB) [optional]

## POWER MODULE (PM)

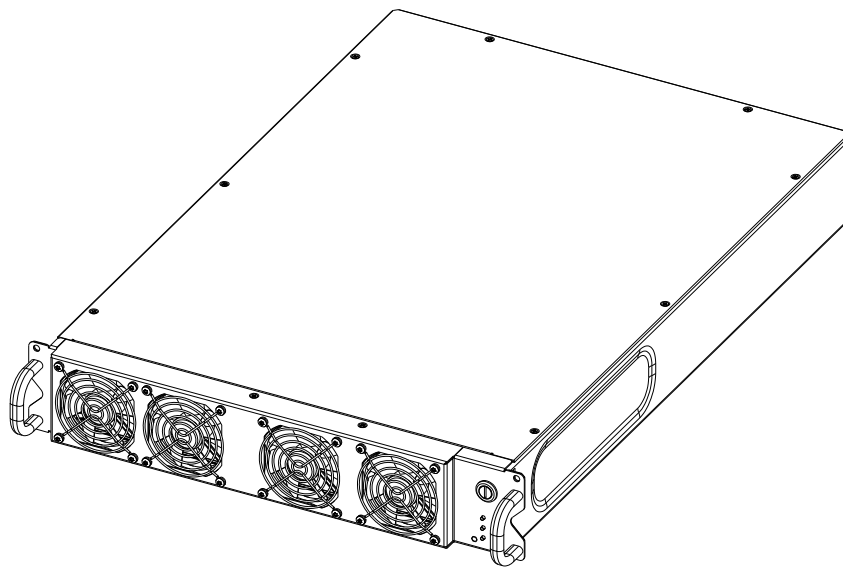

The Power Module (PM) is a three-phase double-conversion UPS module available in the size 15kW (PM15), in the version with IGBTs (M2X 15 PM) or is available in the size 15 and 30kW (PM15, PM30) in the version with Silicon Carbide Mosfets (M2X 15 PM BLUE – M2X 30 PM BLUE). The wiring diagram of the PM, which shows its individual components, is provided below:

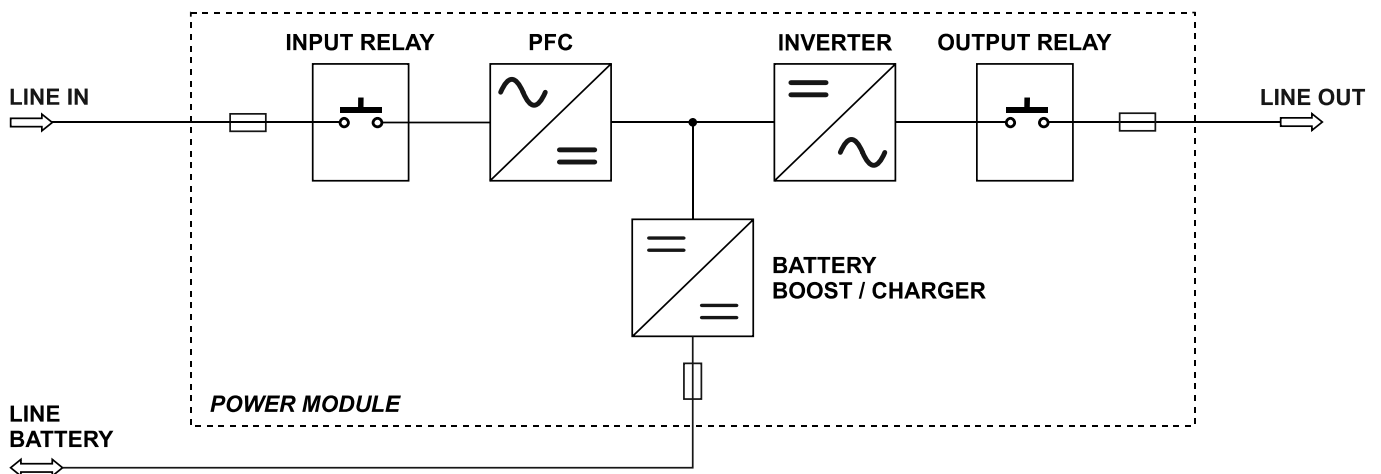

Power Module wiring diagram

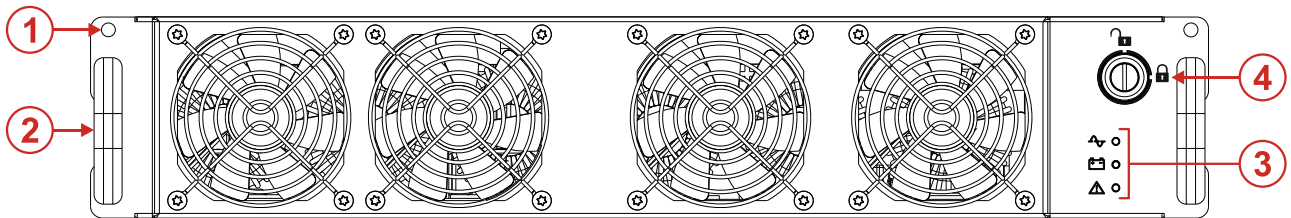

- 1** Holes for fastening the PM to the cabinet using the specific screws

**2** Handles for inserting and extracting the module
- 3** Interface panel

**4** Switch Lock: rotating switch and mechanical lock of the PM to the cabinet

**i** **ATTENTION:** for the insertion and extraction of the PM please refer to the installation manual.

**INTERFACE PANEL**

**Mains operation LED**



- *On steady:* mains operation with good bypass line and synchronised inverter
- *Slow blinking:*
  - 500 ms ON - 800 ms OFF: mains operation with bad or disabled bypass line and/or non-synchronised inverter.
  - 130 ms ON - 2.5 s OFF: module in ENERGY SAVING mode



**Battery operation LED**

- *On steady:* battery operating mode
- *Slow blinking:* battery operation with early low battery or imminent shutdown warning



**Standby/alarm LED**

- *On steady:* alarm present
- *Slow blinking:* Stand-by mode
- *Fast blinking:* initialization communication BUS

+ + *Slow blinking:* Starting

## **BYPASS MODULE 200AMP (BM)**

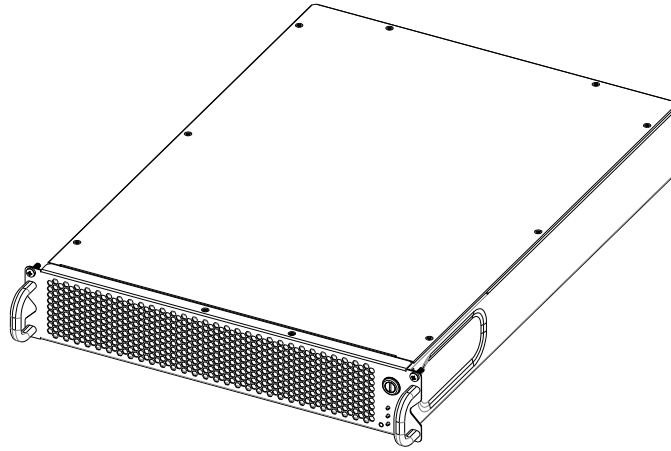

The Bypass Module (BM) allows the direct connection, electronically governed, between input and output of the UPS. In the M2X the BM works in a centralized way for the total amount of power of the UPS, equals to 120 kW. The wiring diagram of the BM, which shows its individual components, is provided below:

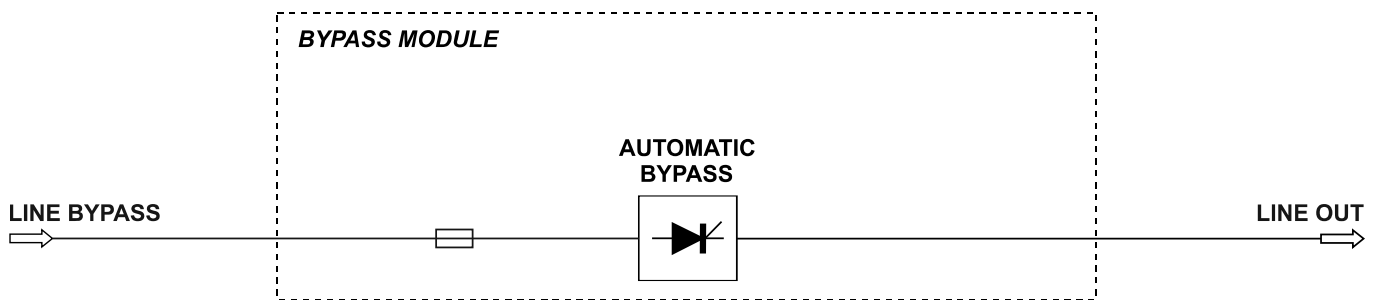

*Bypass Module wiring diagram*

### **BACKFEED PROTECTION**

The UPS has an internal protection against backfeed. This protection acts by means of a sensing circuit which turns the inverter off if a fault within the static switch is detected. During this condition, to avoid interrupting the supply to the connected load, the UPS switches to the bypass line.

If this fault occurs during battery operation, the inverter is stopped.

A volt free contact can be configured to drive a disconnecting device to be installed upstream of the bypass input to the UPS, in this case when a backfeed fault occurs, the system opens the external disconnecting device, hence avoiding the requirement to stop the inverter. Warning: use the service configuration software to set this option.

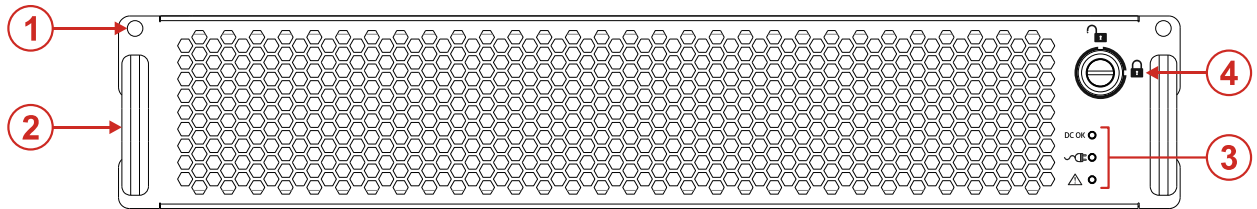

- 1** Holes for fastening the BM to the cabinet using the specific screws

**2** Handles for inserting and extracting the bypass module
- 3** Interface panel

**4** Switch Lock: rotating switch and mechanical lock of the BM to the cabinet

**i** **ATTENTION:** for the insertion and extraction of the BM please refer to the installation manual.

### INTERFACE PANEL

**DC OK**    **LED DC**  
 Green    • *On steady:* Bypass ready

    **LED operation from bypass**  
 Green    • *On steady:* Bypass operating

    **LED alarm**  
 Red    • *On steady:* Alarm  
       • *Slow blinking:* Initialisation

## MAIN COMMUNICATION UNIT (MCU)

This unit is the UPS synoptic. Thanks to the 10-inch color touchscreen display, you can control the system, easily and quickly access key information and main measurements of the entire system or a single power module (to use the synoptic, see the "Display" chapter).

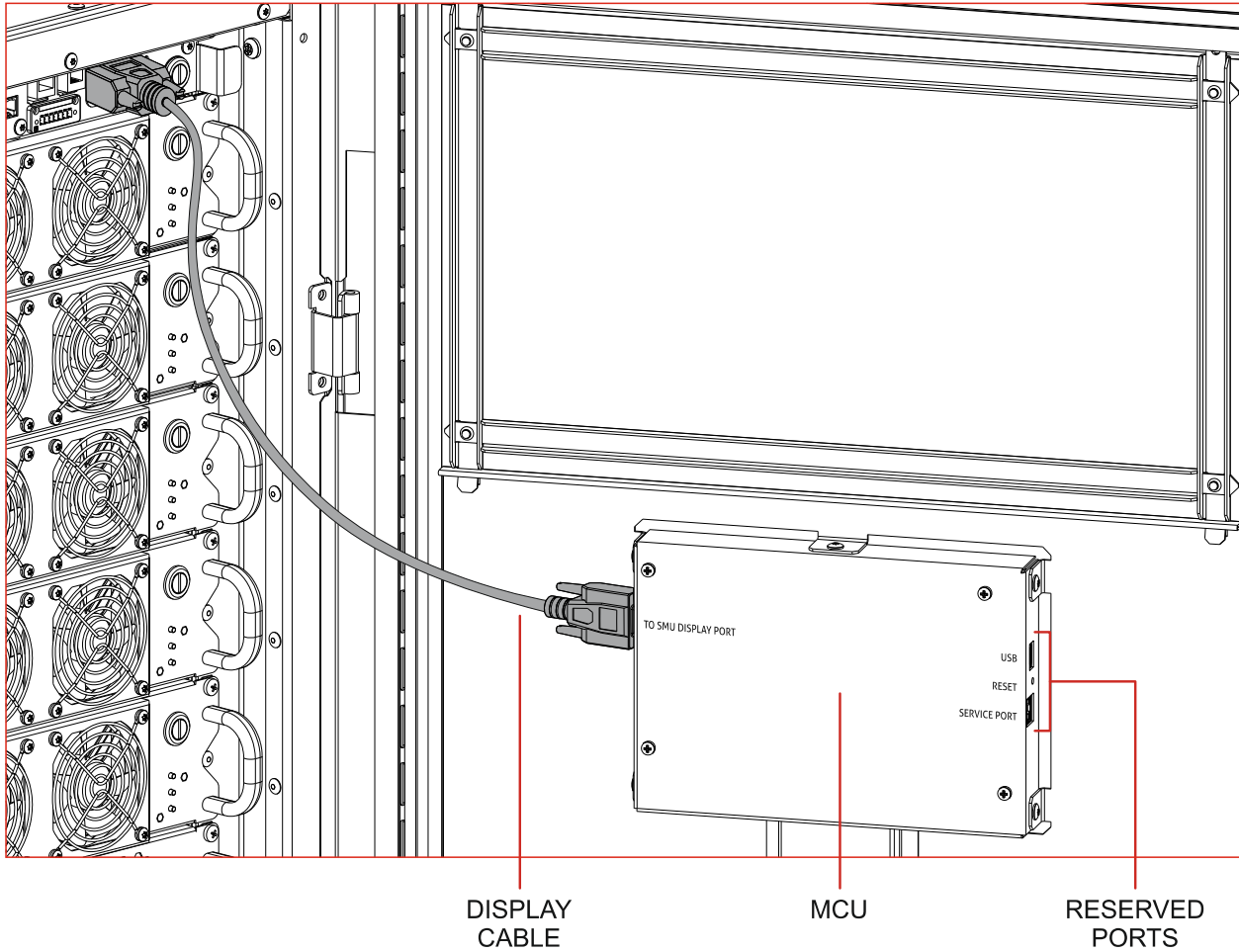

## CONNECTIVITY PANEL (CP)

The Connectivity Panel (CP) realizes, together with the display, the user interface panel of the UPS. The Connectivity Panel includes the system monitoring unit (SMU), a microprocessor-controlled board dedicated to the management of input and output signals, such as temperature sensors, status of external switches (if any), communication boards and it is also responsible of the operation of the display. For more details, please refer to the paragraph "MODULES AND UNITS".

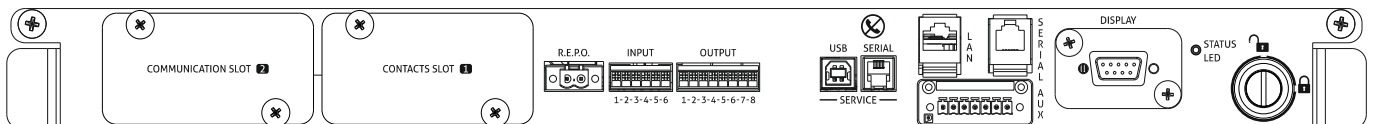

# SMU (SYSTEM MONITORING UNIT)

The system monitoring unit (SMU) is dedicated to the management of input and output signals, such as temperature sensors, status of external switches (if any), communication boards and it is also responsible of the operation of the display. Even this item, in case of a fault, immediately warns the user and the replacing procedure can be easily performed based on a hot swappable principle.

SMU specifically hosts the communication ports for the remote monitoring by the user and personal service. There is a one input for R.E.P.O. (Remote Emergency Power Off); five programmable inputs; four programmable outputs; one input for the connection of an external temperature sensor; one output dedicated to backfeed protection management and one output dedicated to batteries disconnection (in case of serious anomalies).

In addition to the color touchscreen 10" display (on the door), it's also possible to connect to the SMU a PC for update the FW of the PMs and units of the UPS (only for Service).

There are also two SLOTS: one is for the accessory communication board and the other ones are for other accessory contacts. For more details about the use of the interface, please refer to the installation manual.



**ATTENTION: connect to the SMU only non-hazardous low voltage signals**

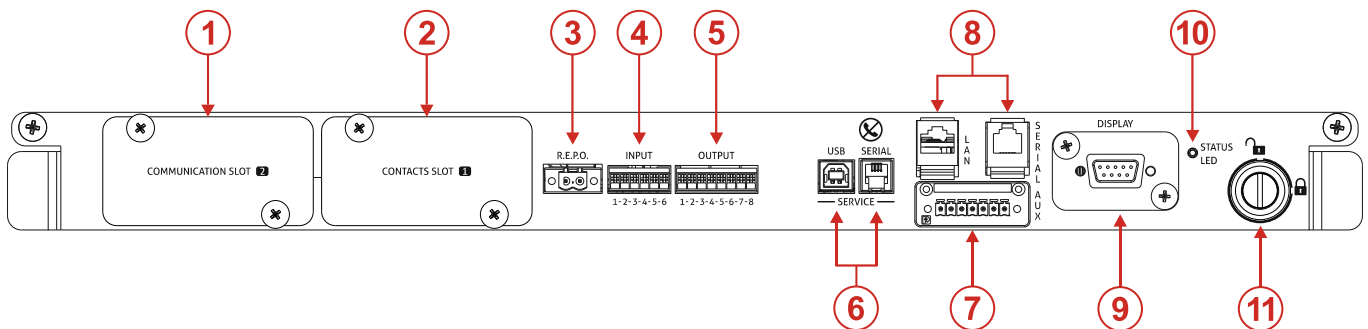

- |                               |                   |
|-------------------------------|-------------------|
| ① Communication Slot (SLOT 2) | ⑦ Signal AUX      |
| ② Contacts Slot (SLOT 1)      | ⑧ NETMAN port     |
| ③ R.E.P.O.                    | ⑨ Display port    |
| ④ Signal input                | ⑩ SMU status LEDs |
| ⑤ Signal output               | ⑪ Switch Lock     |
| ⑥ Service ports               |                   |



**ATTENTION:** for the insertion and extraction of the SMU please refer to the installation manual.

## INTERFACE PANEL

STATUS LED indicate the status of the SMU.



### LED APPEARANCE

- *On steady:* Ready
- *Slow blinking:* Initialization, operating communication BUS
- *Fast blinking:* Initialization, not operating communication BUS
- *Off:* Not ready

## ***PIB (PARALLEL INTERFACE BOARD) [OPTION]***

The PIB (Parallel Interface Board) is a board that allows data exchange between UPSs in parallel. The connection of UPSs in parallel allows you to increase the reliability and power of the system. It's possible to connect in parallel up to four M2X 120 CBC 6 or up to four M2X 120 PCS.

In a parallel system the information is sent between UPS thanks to PIBs and data BUS. In order to increase the reliability, there are two identical connections, one made via PIB1 (blue color) and the other one made via PIB2 (yellow color).

The PIBs are optional boards placed inside the appropriate parallel kit, for more details refer to the specific manual.

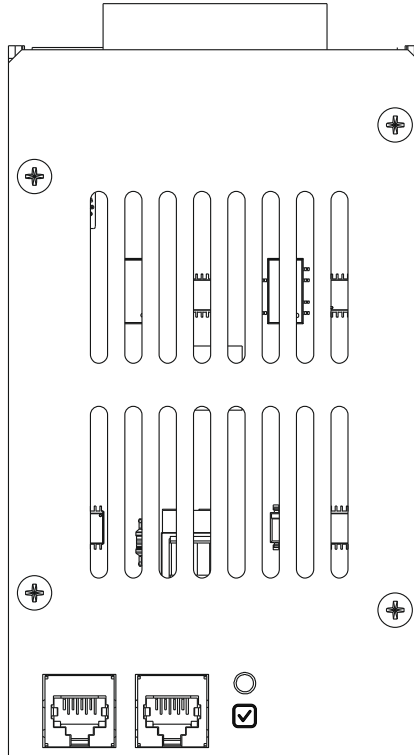

### ***INTERFACE PANEL***



Green

#### **LED parallel operation**

- *On Steady:* Ready
- *Slow blinking:* Not ready

# DISPLAY

Display navigation is divided into 3 levels, according to a tree structure of this type:

**SYSTEM > UPS > MODULES**

**UPS:** it is defined as an equipment, composed of one or more PM columns, in which there is a single BM and a single Display.

**SYSTEM:** it is defined as a group of UPSs connected in parallel. In case of a single UPS, the latter corresponds to the System.

**MODULES:** PM, BM, SMU.

Through the display is possible to:

- view the status of the SYSTEM, UPSs and PMs;
- activate switch on / switch off / battery test / bypass operation commands;
- configure the SYSTEM, access levels and the network services (e-mail sending, anomaly reporting, etc.).

The “Home” page shows a diagram of the general operation status of the SYSTEM. It is possible to interact with the system and see the details through the icons.

**NOTE:** The example shows a 120kW SYSTEM.

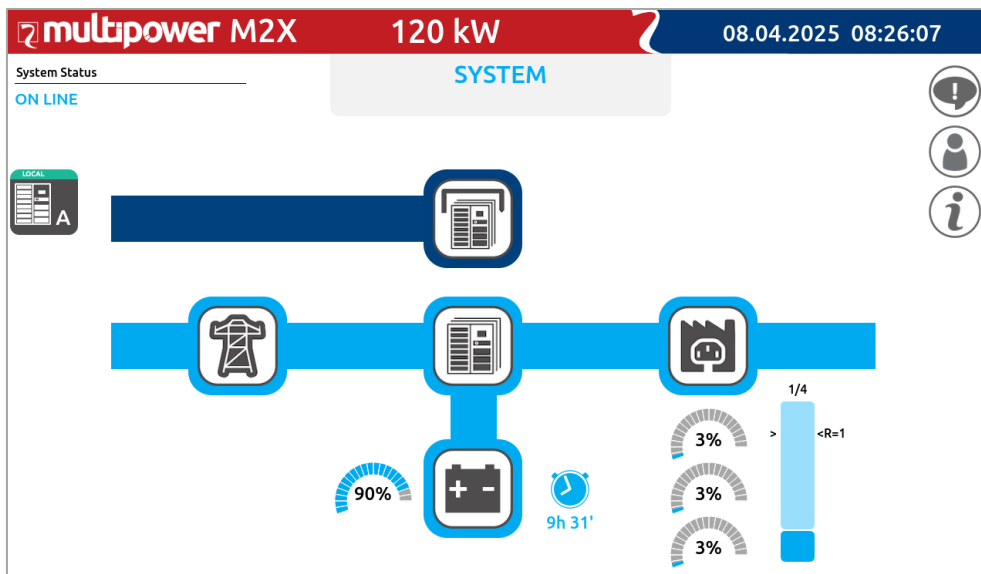

Example of a System with a single UPS

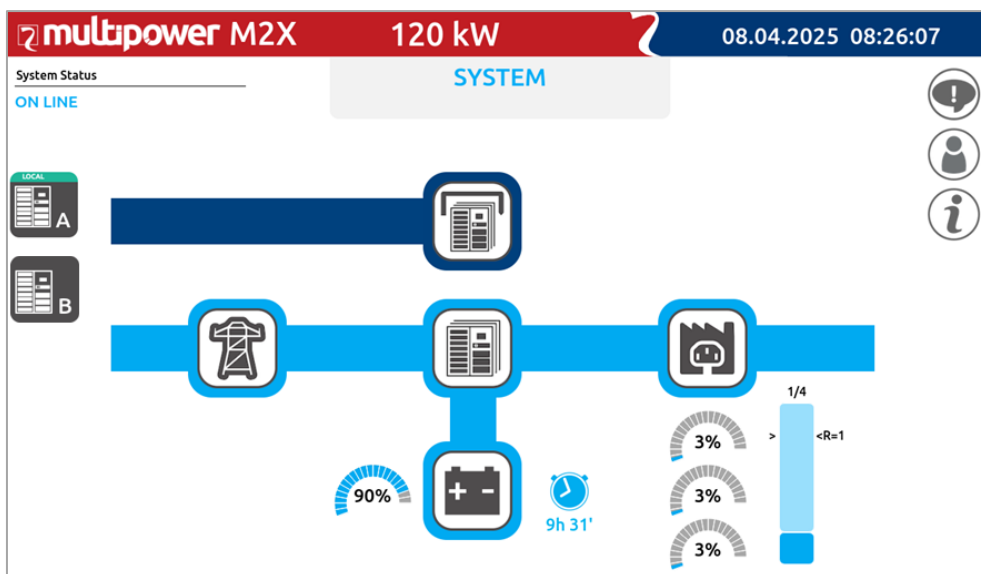

Example of PARALLEL System with 2 UPSs connected



**NOTE:** For the navigation of the SYSTEM refer to “SECTION 1 – SYSTEM”, for UPS refer to “SECTION 2 - UPS” and for PM/BM/SMU refer to “SECTION 3 – MODULES”.

# DISPLAY OVERVIEW

## STATUS BAR

The status bar at the top shows UPS model, configured power, UPS power and date and time. Configured power and deliverable power can be different when some modules are not active. If they are the same a single value is showed.

**NOTE:** The example shows a 120kW SYSTEM.



## ICONS, SYMBOLS AND TEXTS

### MAIN DIAGRAM

The main active icons present in the diagram are:



Mains input



Output



Battery



Automatic static bypass



System status

In general, the color and the shape of the icons provide instant information to the status of the system:



Grey:  
communication lost  
(Com-Lost)



Light blue:  
normal status



Blue:  
load on status



Orange:  
anomaly



Red:  
alarm

Colored bars indicate the route that power is following in the system:



Normal mode. The power goes from input to load through UPS that loads battery if they are connected



Working on Bypass. Power flows through static bypass



Battery working. Power flows from battery to load through UPS. Pay attention to back-up time and charge percentage of the battery



Load supplied solely via Manual Bypass (*MANUAL BYPASS SWITCH closed*)

In addition to the main diagram, there are additional information icons:

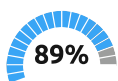

% Battery charge gauge  
it represents charge percentage of the battery



Back-up time estimate  
The calculus of back-up time is function of applied load and the battery charge status

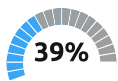

L1



L2



L3

% Load gauge phase 1, 2, 3  
are based on power that active modules can be kept

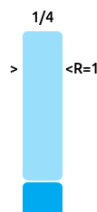

Redundancy bar  
see paragraph "Load level and redundancy system status"

**ACTIVE TEXT AREAS**

Parallel System Status

ON LINE

At the top left of the display, active area which reports the current state of the SYSTEM.

POWER MODULE  
[A.1.1]

At the top center of the display, active area showing the name and possibly the address (A, B, C, D) of the SYSTEM, UPS or Module being viewed.

Ups Status

MANUAL BYPASS ACTIVE

At the top right of the display, active area which reports the current status of the selected UPS or Module (present only when the UPS or Module tabs are displayed).

**UPSs LIST**



Address list of all UPSs of the SYSTEM. Every UPS that composes the system has a unique address (identified to a letter from A to D). The written LOCAL informs that this display belongs to this specific UPS.



Some symbols may appear inside the icon, which identify a particular state of the related UPS. For further information on the meaning of the possible symbols, refer to SECTION 2, "UPS/modules status" paragraph.

**MENU**



On the right side of the Home page there are a series of icons that allow you to set commands, configurations or view various information relating to the SYSTEM.

**NOTE:** the menu may change depending on the pre-set access level.



in the various pop-up screens, on the right side at least one of these icons will always be present:



button to exit the active pop-up screen (any changes will not be saved)



button to confirm any insertion and/or modification operations



For further information refer to the dedicated paragraph **Menu Entries**.

**SLIDE SWITCHES STATUS**

Located on the "Control Panel" page , these slide switches are necessary to activate the various system on/off commands.



OFF



ON - LOCK STATUS



ON



OFF - LOCK STATUS



PARTIALLY ON  
(SOME "OFF" - SOME "ON")



UNAVAILABLE

**LEGEND OF THE USED SYMBOLS**

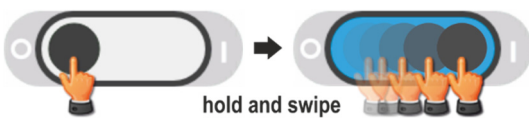

**SWIPE LEFT-RIGHT**

Movement for the sliding graphical elements for the status switch from O to I.

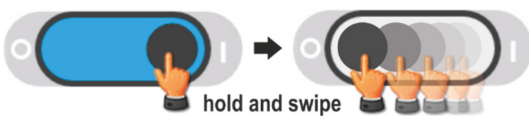

**SWIPE RIGHT-LEFT**

Movement for the sliding graphical elements for the status switch from I to O.

## LOAD LEVEL AND REDUNDANCY SYSTEM STATUS

The “Home” page provides a graphic bar showing the current load level and the system redundancy.

**Load level:** the bar is a representation of the number of PMs configured and their use as a function of the applied load level:

- Dark tonality indicates the number of operating Power Modules (PMs) that are necessary to supply the current load.
- Clear tonality indicates the number of operating PMs but not necessary to supply the current load.
- Grey colour indicates one or more unavailable PMs.

NOTE:

Whenever the installation includes one or more UPSs in parallel, the bar will show the SYSTEM load level and not the single UPS load level.

**Redundancy:** To increase system reliability, the user can add one or more redundant PMs rather than just install the number strictly required to supply the load.

The diagrams below show the possible “Load level” bar status according to the system conditions with respect to the load level, redundancy and PM availability.

The example shows a 120kW SYSTEM with PM30 modules. This system includes: 1 UPS, 5 PMs configured, 1 of which as redundant (R=1); 4 PMs present to supply the load.

### Normal operation (light blue colour)

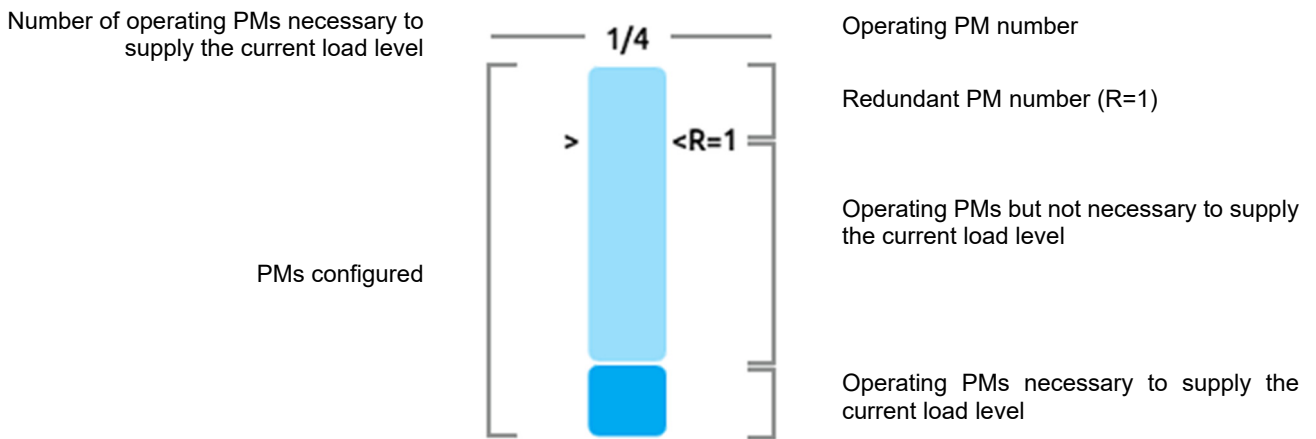

### Redundancy level reduction (orange colour) <sup>(1)</sup>

caused by excessive load level

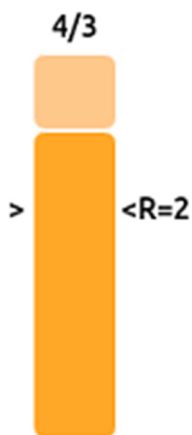

caused by a PM unavailability



### Redundancy lost (red colour)

due to full load level

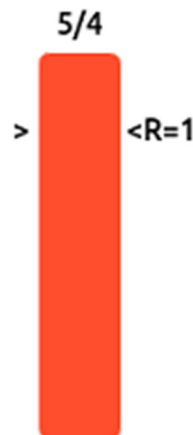

due to complete PMs unavailability



(1) Only with 2 or more modules as redundant (R≥2)

**NOTE:** All PMs, including the redundant units operate together sharing the load. Thanks to this reliable feature, we strongly suggest that the user configures one or more redundant PM according to the power required and the installation type.

## SECTION 1 - SYSTEM

The home page provides a schematic view of the overall operating condition of the SYSTEM. It is possible to interact with the SYSTEM and access further information via the icons. Depending on the current state of the SYSTEM, this page may assume different appearances as shown in the examples below. The following are some examples of the home page whilst displaying various operating conditions:

**NOTE:** The example shows a 120kW SYSTEM.

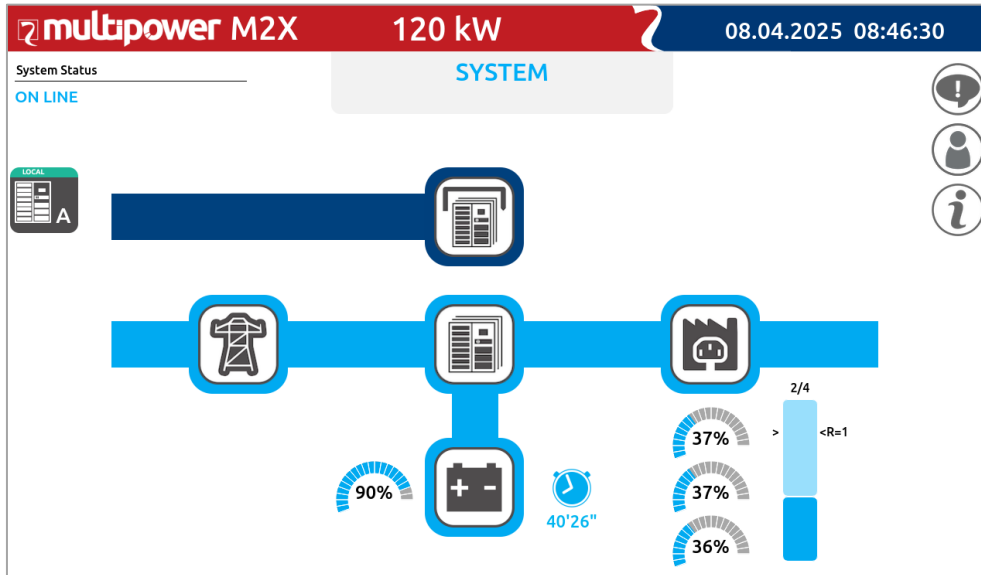

Home page displaying SYSTEM in ON LINE mode (load on inverter)



**NOTE:** In this following screen, we will refer to a Single Input System.

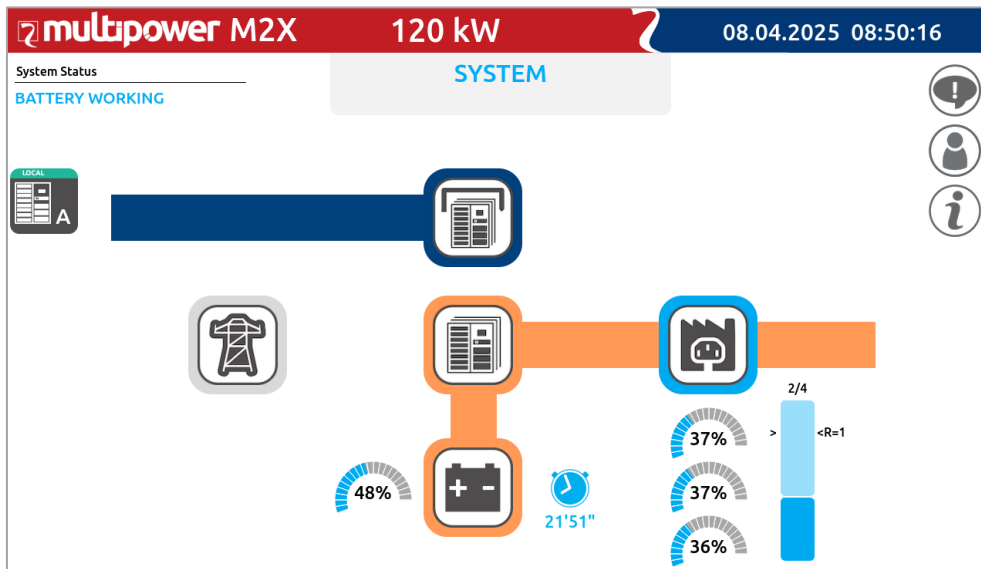

Home page displaying BATTERY WORKING status

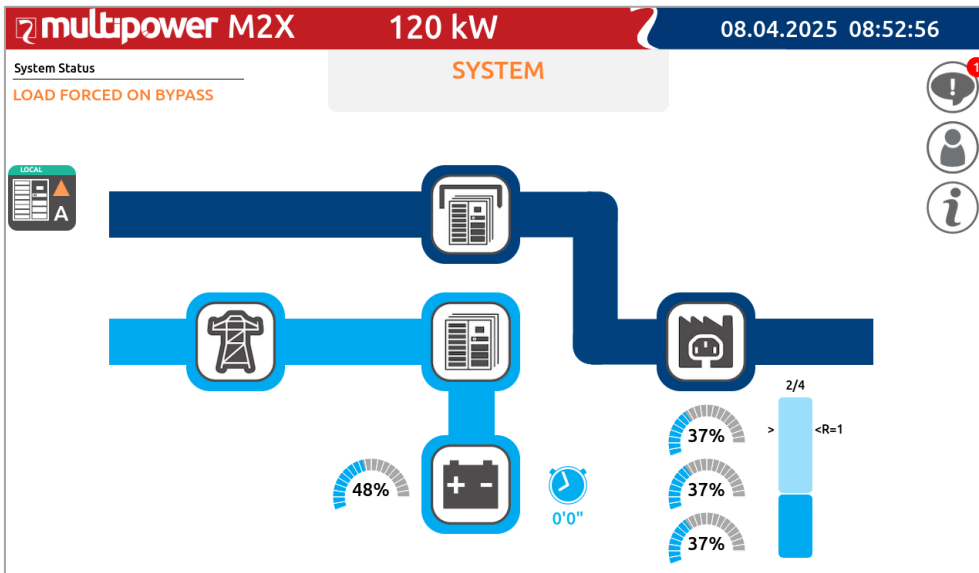

Home page displaying SYSTEM in STATIC BYPASS mode (load forced on bypass)

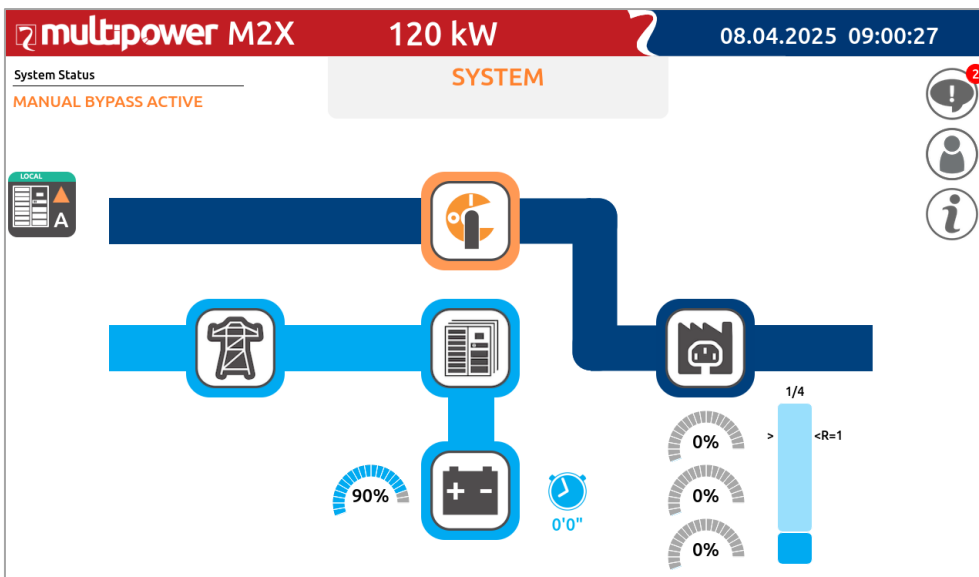

Home page displaying MANUAL BYPASS SWITCH CLOSED (load supplied solely via manual bypass)

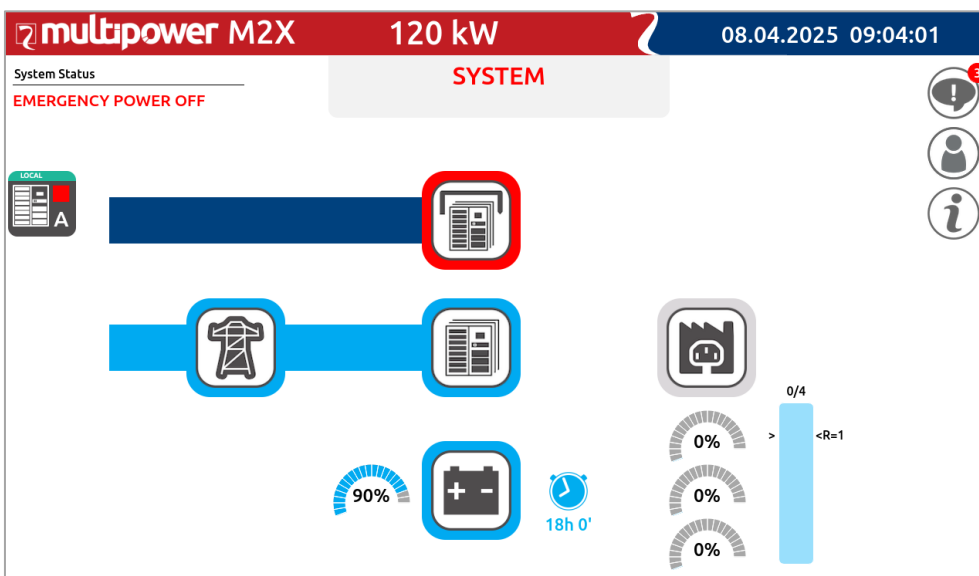

Home page displaying System with EPO (Emergency Power Off) ACTIVE

## SYSTEM MEASUREMENTS

Through the icons on the Home page it is possible to access the pop-up screens that display the main electrical values of the system.

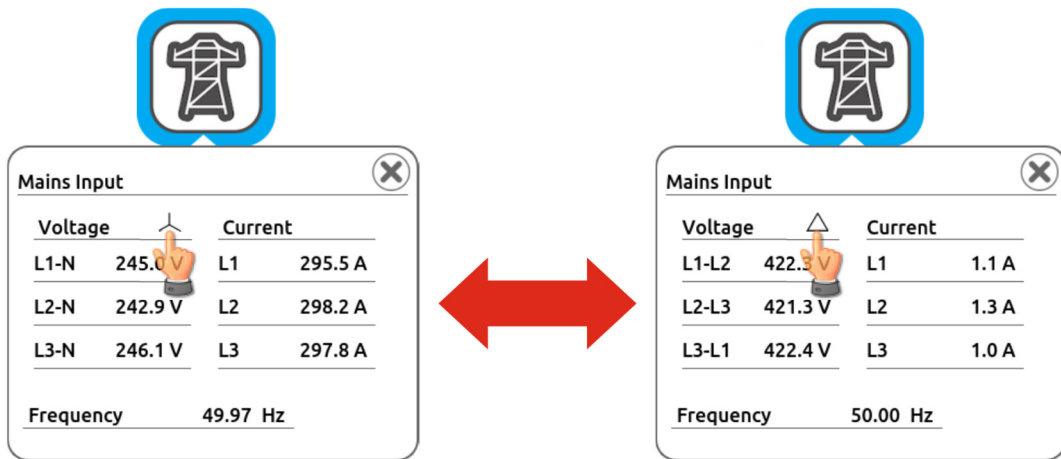

*Mains Input page:*  
 displays the status and the parameters relating to the system input.  
 By pressing the indicated symbols, it is possible to switch from one image to another.

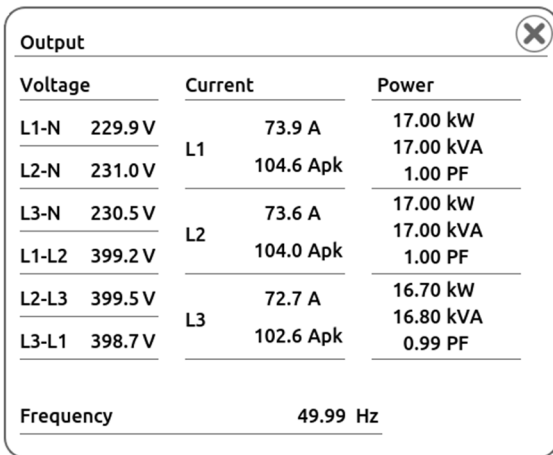

*Output status page:*  
 displays the status and the parameters of the system output

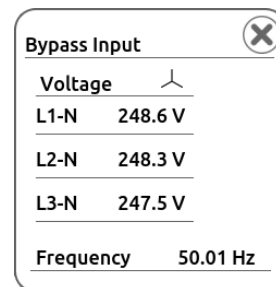

*Bypass section page:*  
 displays the status and the parameters of the system bypass line

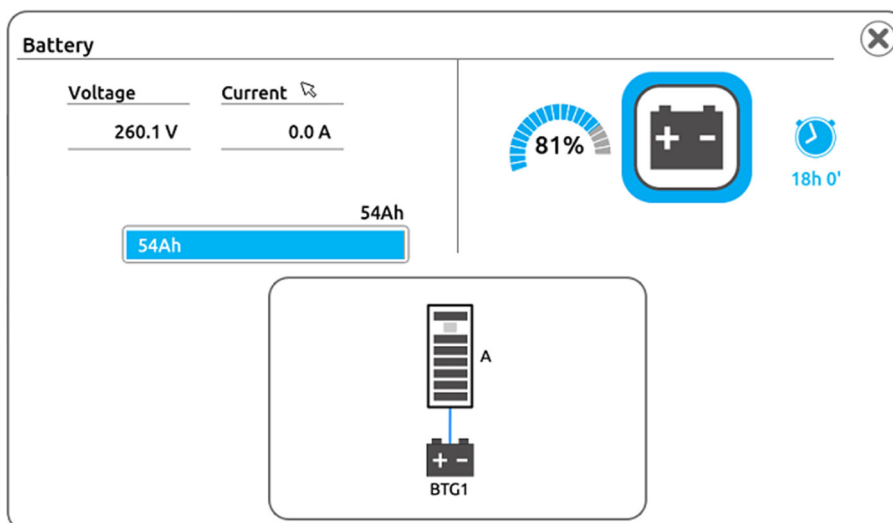

*Battery status page:*  
 displays the status and the parameters related to the system batteries

## SYSTEM STATUS

Through the central icon called “System status” it is possible to view all the synoptics of the UPS present in the system.



**NOTE:** Some images contained in this document are for information purposes only and may not faithfully demonstrate the parts of the product they represent.

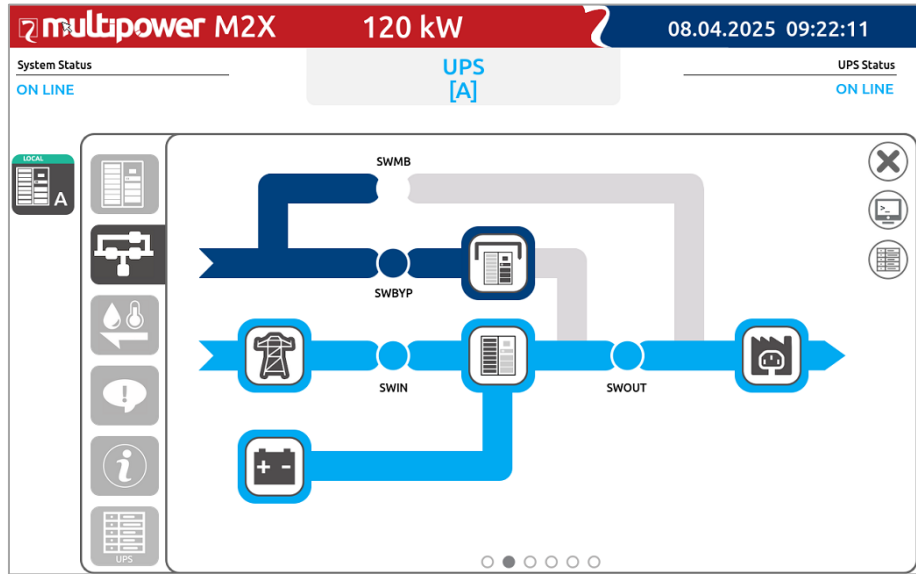

## MENU ENTRIES

On the right side of the Home page there are a series of icons that allow you to set commands, configurations or view various information relating to the SYSTEM.

**NOTE:** The list of icons changes in relation with the preset access level.



**Notifications/alarm**



**Access level selection**

**NOTE:** the icon changes depending on the preset access level (see “Access level selection” paragraph)



**Global System information**



**Command panel**

**NOTE:** available only with “Power User” or “Expert” access level



**Settings menu**

**NOTE:** available only with “Power User” or “Expert” access level

## NOTIFICATION/ALARM



In the case of a particular events (command, warning, anomaly or alarm) a notification number icon will also be present indicating the existence and number of events that are active at that time.

If you tap on the icon, a pop-up will appear showing the individual alarms in detail.

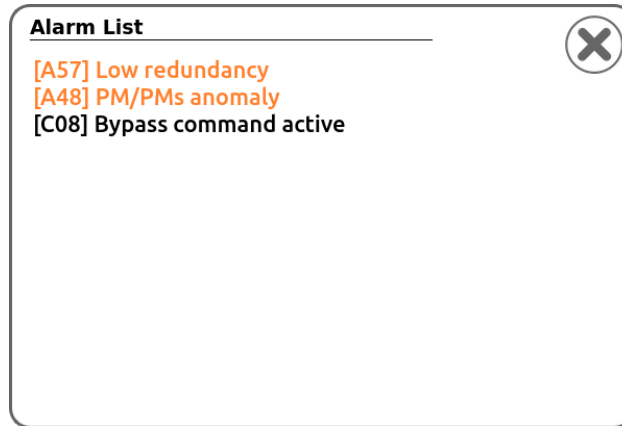

In the list of alarms:

- Black messages indicate Command (C) alarms;
- Orange messages indicate Warning (W) or Anomalies (A) alarms;
- Red messages indicate Lock (L) or Faults (F) alarms.

For the alarm code list, refer to the "STATUS/ALARM CODES" chapter.

**ACCESS LEVEL SELECTION**



This icon enables the selection of the access level for the user operating the System. If preset, a safety password may be requested, based on the selected level.  
 NOTE: the icon may be different depending on the preset access level

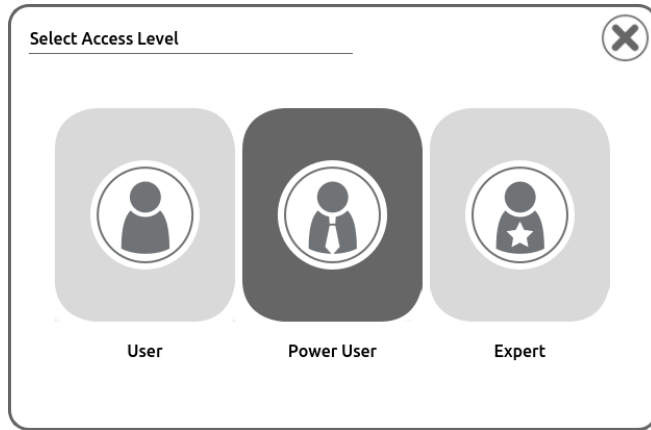

*Access level selection page*



**User:** only allows you to view data and information from the System, UPS, PM. With this level it is not possible to operate on the system, access commands, configurations or change system settings.



**Power User:** adds the ability to operate on the System, access commands or change system settings. Setting the Power User password prevents access to the “Command launcher” and “Settings menu” to unauthorised users.



**Expert:** adds the ability to configure and modify ALL System parameters. This level is reserved only for trained personnel with knowledge of the System parameter configuration. A password is required. Insert the preset password “**expert**” to access this level.

**NOTE:** the password may be different to the default setting if it has been previously configured. To set/change your password refer to the “Change Password” paragraph.

**GLOBAL SYSTEM INFORMATION**



Through this icon it is possible to view general information about the System. By tapping on it a pop-up will appear to choose which information to see in detail.

**NOTE:** The example shows a 120kW SYSTEM

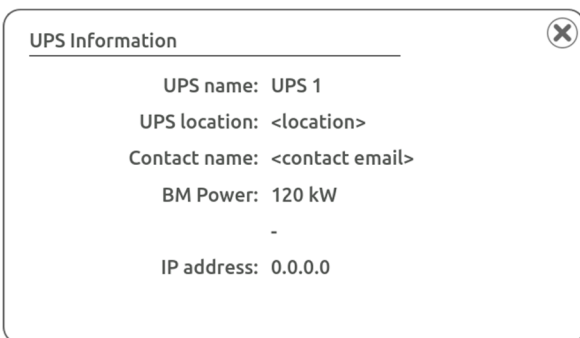
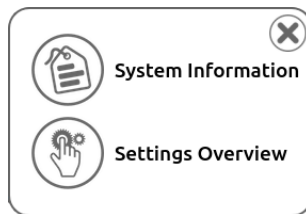

*System Information*

allows you to view general System information. (System name, IP address, Display software, etc.).

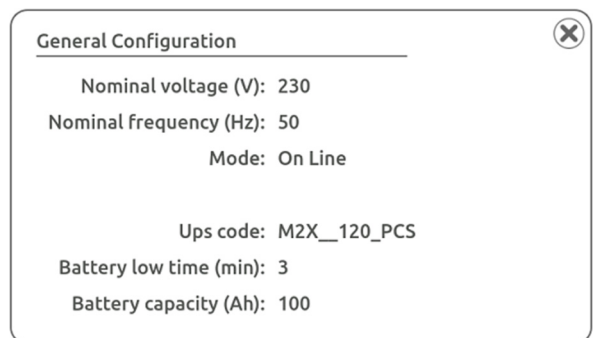

*Settings Overview*

allows you to view the overall System parameters set by the user.

## COMMAND PANEL



Through this icon it is possible to activate the various System On/Off commands.  
By tapping on it the System commands panel will open.  
NOTE: available only with "Power User" or "Expert" access level.

### SYSTEM OFF/ON COMMAND

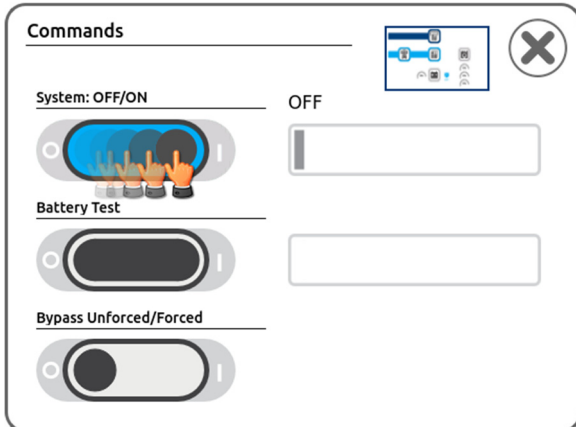

Operate the sliding switch from O to I to switch the System ON.

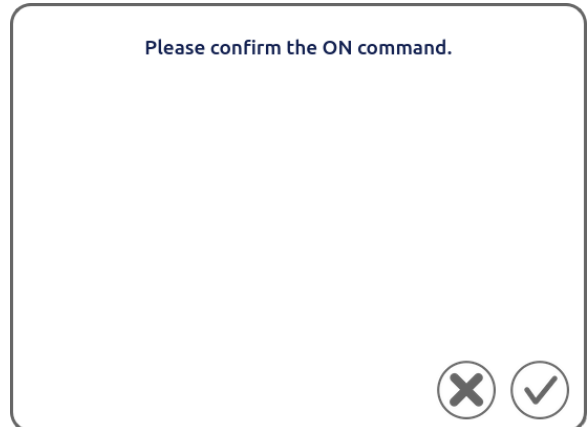

A confirmation of the action is required for some of the commands.

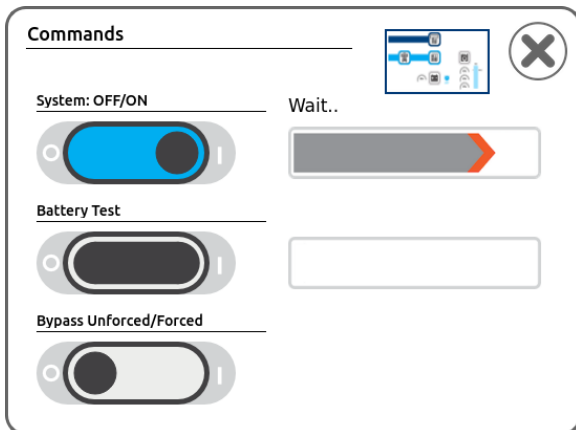

After confirmation, a bar will show the progress of the command completion.

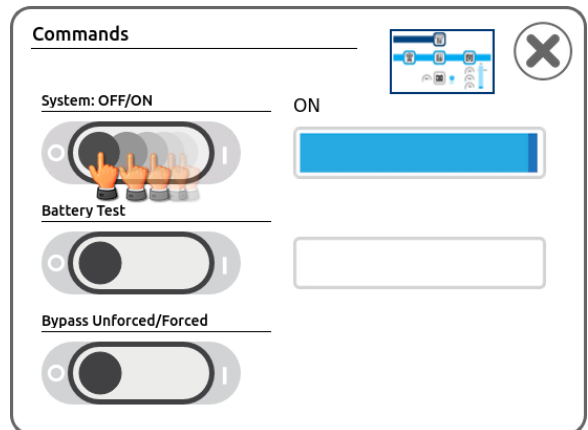

Operate the sliding switch from I to O to switch the System OFF.

### BATTERY TEST COMMAND

Operate the sliding switch from O to I to execute the battery test.  
The progress bar shows the progress of the battery test.

Our system are equipped with a built-in battery test function. This function forces the System to work from battery and monitors the battery voltage under load to check if the battery is healthy.

**NOTE:** the System switches to battery just for the short time needed to execute the battery test and only when the main supply is present as backup, therefore the battery charge level and the load safety are not compromised.

The battery test is activated only when the System is ON, the SWOUT is closed and the battery charge level is  $\geq 90\%$ . Otherwise, the test will not be executed immediately, however the command remains active and the battery test will start as soon as these conditions are met.

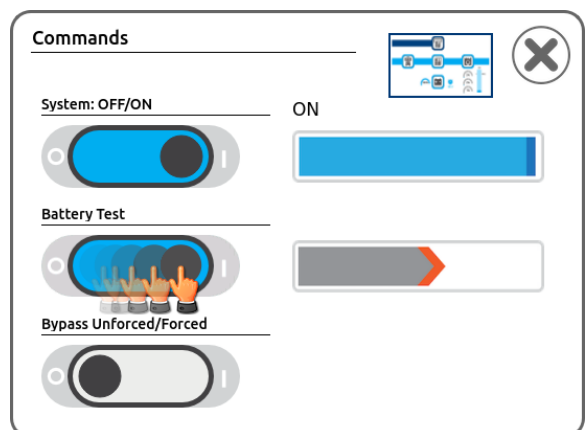

### BYPASS UNFORCED/FORCED COMMAND

Operate the switch from O to I to switch the System on static bypass. A confirmation is required.

**NOTE:** This command is available only if the System ON command is activated and, if enabled, the System will be switched into bypass. If the System is in Stand-by mode, the command is disabled. Switch the Bypass Unforced/Forced command to "O" to switch the load back onto the inverter.



## SETTINGS MENU



Tap the Settings Menu icon to access the list of System settings icons.  
**NOTE:** available only with “Power User” or “Expert” access level.

“Systems Configuration” icon is available only with “**Expert**” access level.

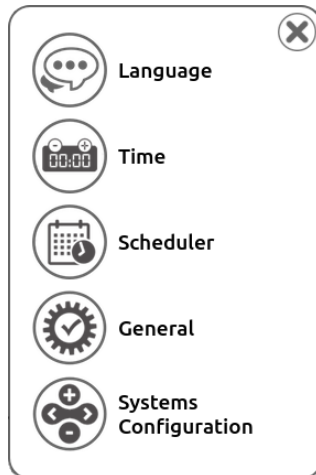

“Settings Menu” page in the “**Expert**” mode

To make the changes to the various settings effective, it is necessary to confirm the operation with the appropriate button ✓

## LANGUAGE CONFIGURATION



Enables the language configuration of the system menus.  
Tap the flag to select the language.



## DATE AND TIME SETTING



This screen enables the user to configure the date and the time of the system.

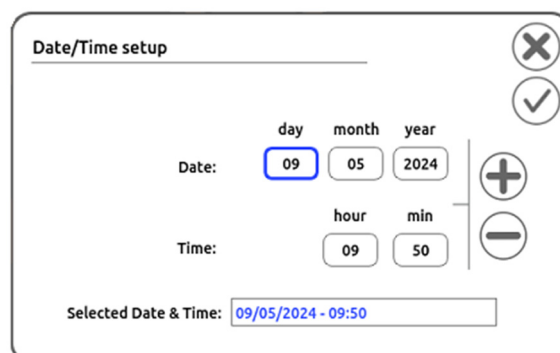

**SCHEDULED OPERATIONS SETTING**



This screen enables the configuration of the scheduling for some automatic operation (e.g. battery test)

**GENERAL SYSTEM SETTINGS**



Through this icon it is possible to access the General System settings menu.  
**NOTE:** The list of icons changes in relation with the preset access level.

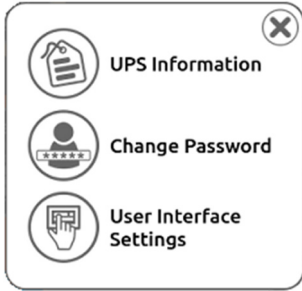

*“General” menu in the “Power user” mode*

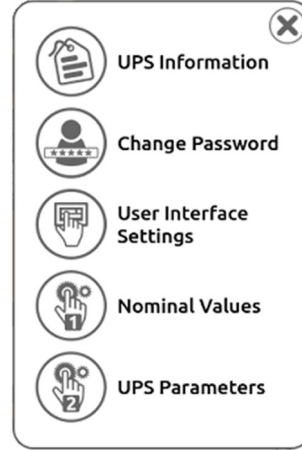

*“General” menu in the “Expert” mode*

**SYSTEM INFORMATION**



Through this icon you can enter the system name, place of installation and a reference ID for the system.

**CHANGE PASSWORD**



Through this icon it is possible to set or change the password for the various access levels.  
**NOTE:** password protection has to be configured from the higher user level.

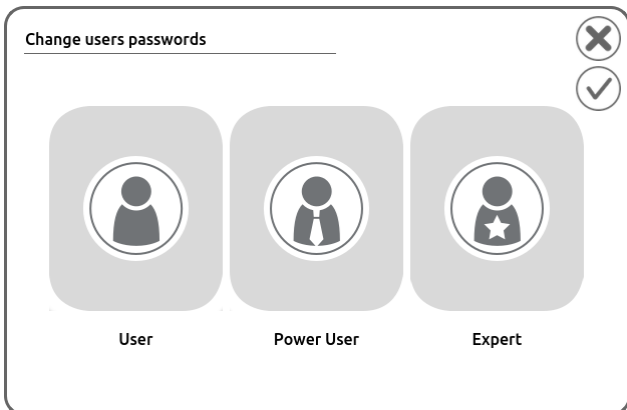

*“Change users passwords” page*

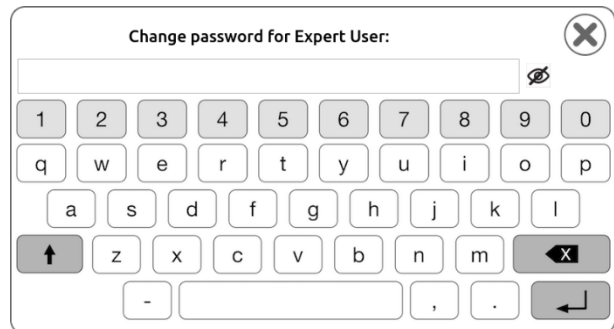

*Keyboard for entering password*

Touch one of the three user icons matching the access level for which it is intended to set or change the password and type/change the password.

To validate the new password, after entering it you must confirm using the appropriate icon



**WARNING:**

If no password is configured for a given user-level, the function relative to that access level are available to anyone.  
Pay attention not to forget the password. If the access level password is forgotten, it is impossible to access the specific operations for that level.

**USER INTERFACE SETTINGS**



Through this icon it is possible to set:

- Timeout home page: the inactivity period (in minutes) after which the Home page will be displayed
- Buzzer Mode: enable/disable the buzzer

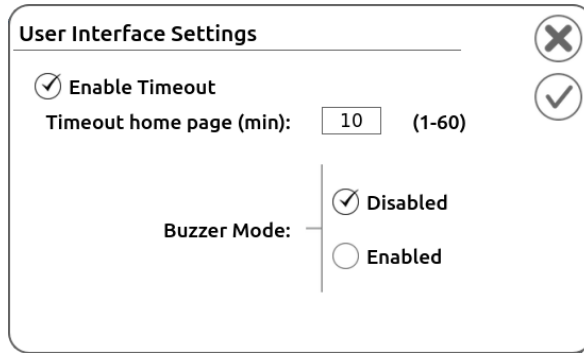

**NOMINAL VALUES**



From this screen, available only with **Expert** access level, the user can set the rated output voltage, the frequency and the operation mode

**WARNING:** These settings must be correctly configured by expert personnel only; improper settings can lead to severe damage of the load connected to the System output.

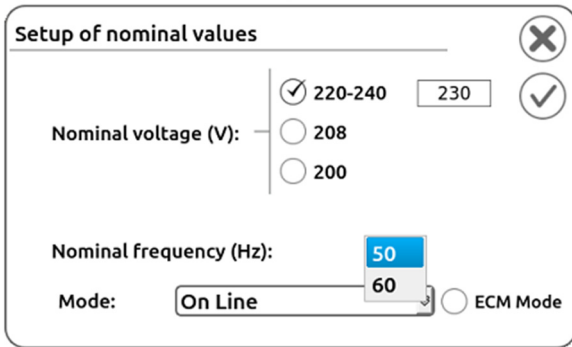

*Nominal frequency configuration*

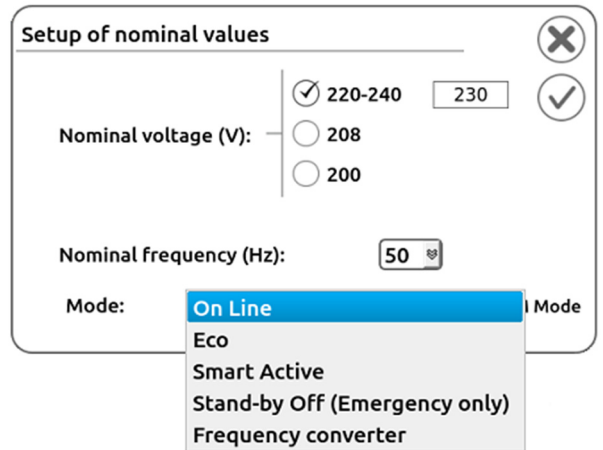

*Operating Mode configuration*

**Nominal voltage (V):** to set the desired output voltage, tap on the corresponding select box. The first selection is customisable by writing the voltage in the text box. By selecting a low output voltage (200 and 208V), the output power will be consequently reduced. Refer to the graph below:

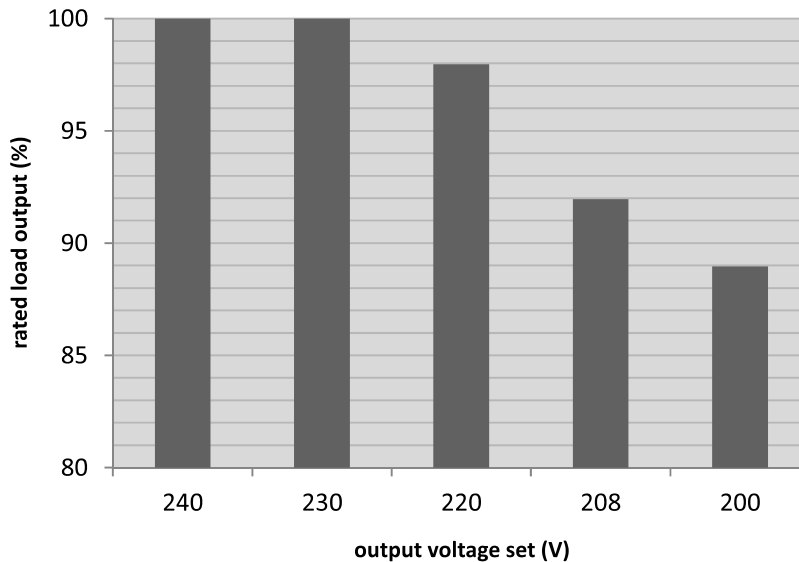

**Nominal frequency (Hz):** To set the desired output frequency, tap on the corresponding select box. Preset frequencies are 50 and 60 Hz. Custom output frequencies are set by using the service configuration software. If a custom output frequency is set the value can be read within the text box.

**NOTE:** The frequency setting is available only when the UPS is in stand-by or the output switch is open.

**Mode:** select the desired operational mode from the drop-down menu. Refer to the Chapter “OPERATING MODE” for further details.

**UPS PARAMETERS**



From this screen, available only with **Expert** access level, the user can set the estimated runtime (expressed in minutes between 1 and 60), below which the system displays the battery low alarm and the buzzer starts to beep. [Default → 3 min].

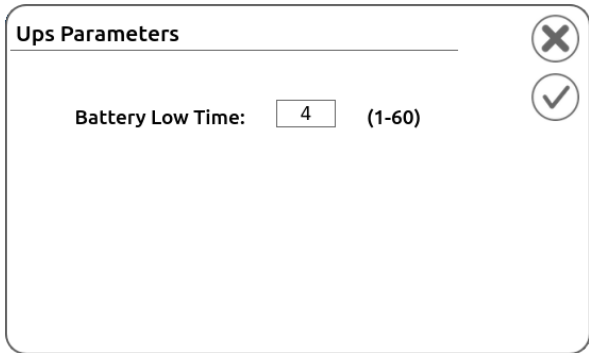

**ADVANCED SYSTEMS CONFIGURATIONS**



Through this icon it is possible to access the advanced System configurations. **NOTE:** available only with “Expert” access level.

**IMPORTANT:** this level is reserved only for trained personnel with knowledge of the System parameter configuration.

From this screen it is possible to activate/deactivate the modules of each individual UPS present in the System, configure the batteries, set the maximum power of the System. The current configuration of the selected UPS is displayed in the center of the screen.

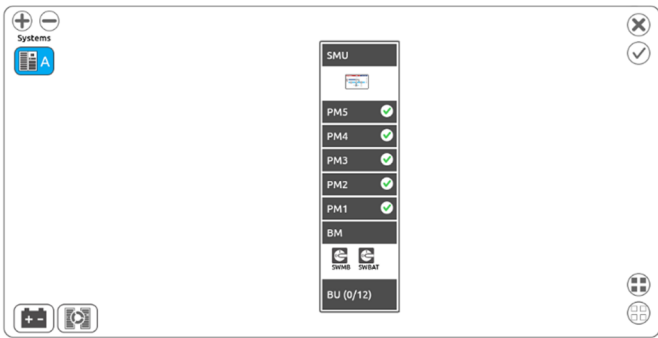

M2X 120 CBC 6

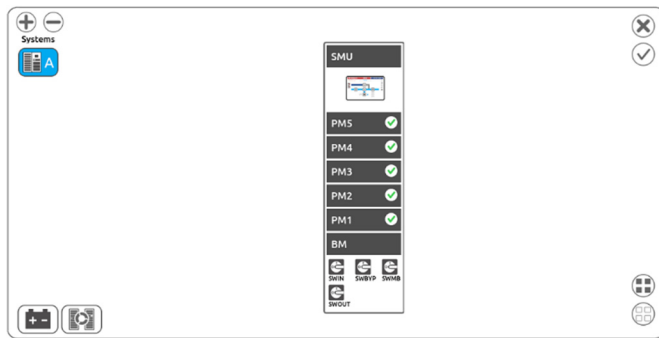

M2X 120 PCS

The power module size (PM15/15kW, PM30/30kW) must be specified before selecting the number of modules installed in the system.

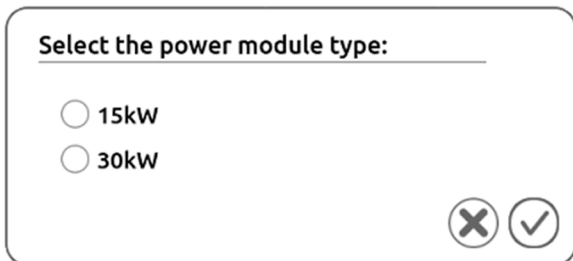

**SYSTEM CONFIGURATION**



Systems



Allows selection of the UPS to be configured. Using the + and - keys it is possible to add or delete one or more UPSs from the System.



Module configured as present in the System.



Module configured as not present in the System.



Module not selectable



Selects all of the elements within the UPS.



De-selects all of the elements within the UPS.

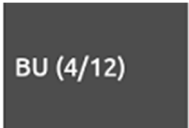

Setup of Battery Units

**BATTERY UNITE CONFIGURATION**

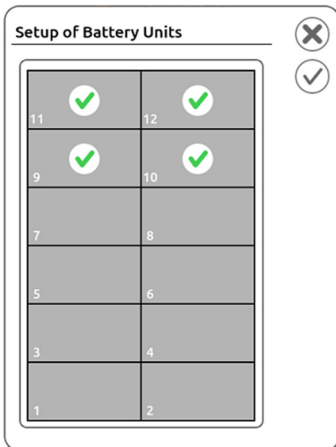

Through this icon it is possible to access the batteries unit configurations



Battery module configured as present in the System.



Battery module configured as not present in the System.

**BATTERIES CONFIGURATION**



Through this icon it is possible to access the batteries configurations.

There are 2 possible battery connection types:

- Shared: with a single battery connection shared by all the UPS within the system.
- Separate: each UPS Cabinet is connected exclusively to one or more Battery Cabinets electrically separated from the Battery Cabinets connected to the other UPS.

According to the chosen battery connection, it is possible to select the battery type and set the battery capacity (Ah).

**Setup of Battery Groups**

Choose battery group connection type:

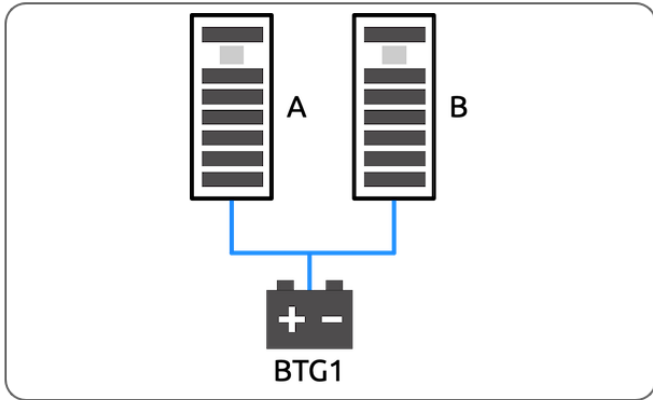

The diagram shows two battery racks labeled A and B. Each rack contains six battery cells. Blue lines connect the bottom of both racks to a single battery unit labeled BTG1, which has a positive (+) and negative (-) terminal.

Battery Capacity:

1 x  Total System capacity: 600

*Shared batteries*

**Setup of Battery Groups**

Choose battery group connection type:

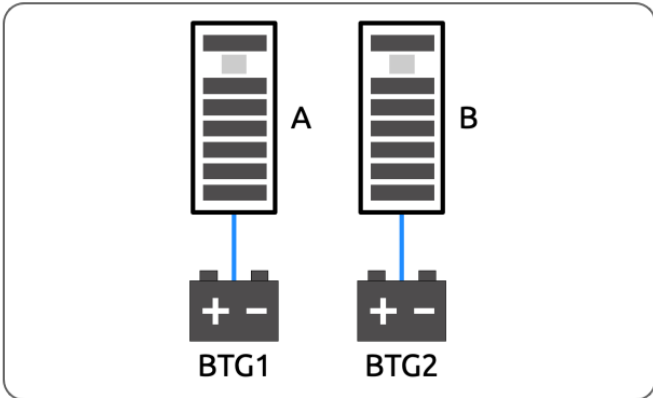

The diagram shows two battery racks labeled A and B. Each rack contains six battery cells. Blue lines connect the bottom of rack A to a battery unit labeled BTG1, and the bottom of rack B to a battery unit labeled BTG2. Each unit has a positive (+) and negative (-) terminal.

Battery Capacity:

2 x  Total System capacity: 1200

*Separated batteries*

**SYSTEM POWER SETUP**



Through this icon it is possible to setup the desired System power. Redundancy will be automatically calculated based on the set power compared to the system configuration.

**Setup of System Power**

Enter the desired system power:

The System will have redundancy: 1

## SECTION 2 - UPS



The UPSs connected to the SYSTEM are shown on the left side of the Home page. Every UPS that composes the System has a unique address (identified by a letter from A to D). The label LOCAL informs that this display belongs to this specific UPS.

NOTE: alongside there is an example of a parallel system composed by 2 UPSs



Some symbols may appear inside the icon, which identify a particular state of the related UPS. For further information about symbols, refer to “UPS/modules status” paragraph in this section.

By tapping on the icon of one of the UPS, you will access the configuration and status page of the selected UPS.

On the side there are various selectable tabs, explained below, to set or monitoring in detail the main parameters of the selected UPS.

### “UPS STATUS” TAB

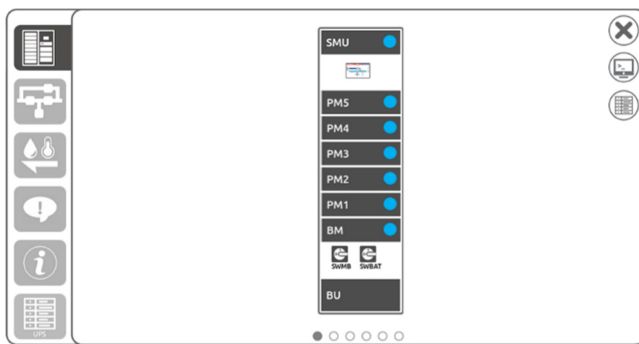

M2X 120 CBC 6

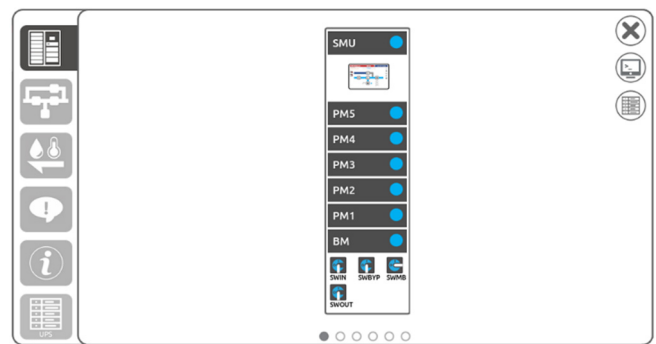

M2X 120 PCS

The first tab shows the graphic composition of the UPS and the current status of the parts that compose it, specifically:



or



Indicates the status of the external Maintenance Bypass Switch of the selected UPS. BLUE: Switch open - ORANGE: Switch closed



By tapping the display icon, it is possible view the local display information



Depending on the symbol displayed, reports the status of the various available modules (PM, BM, SMU). For further information refer to the next paragraph “UPS/modules status table”



Module configured as not present in the System



UPS Command Panel (*Power User* and *Expert* level only). Allows you to turn the UPS On or Off. For operation, follow the same instructions given in the SECTION 1, “Command Panel” paragraph



By tapping this icon (available only in expert mode) you can view the UPS alarm history (modules also have their own specific alarm history table).

**“HISTORY ALARM” TAB**

**Event log of UPS A** ✕

E	Type	DateTime	Code and Description
		28-01-24 17:23:25	[L23] Output overload L1
		28-01-24 17:23:25	[L24] Output overload L2
		28-01-24 17:23:25	[L25] Output overload L3
		28-01-24 17:23:25	[F64] PM/PMs fault/lock
		28-01-24 17:23:25	[L63] Bypass locked
		28-01-24 17:23:25	[E14] Load on bypass
		28-01-24 17:23:25	[A22] Load > user threshold L1
		28-01-24 17:23:25	[A23] Load > user threshold L2
		28-01-24 17:23:25	[A24] Load > user threshold L3
		28-01-24 17:55:38	[A56] PM/PMs commLost
		-----	[E08] Power On
		-----	[E08] Power On

---

Command

Warning

Anomaly

Fault

Lock

---





Event start

























Event End















*This tab represents alarm of UPS or modules*





**UPS/MODULE STATUS**

In addition to the colors that can highlight anomalies/alarms or operating states of the UPS, thanks to particular pictograms, the status of UPS and each individual module (PM, BM, SMU) is reported.

<b>UPS STATUS</b>	<b>NORMAL OPERATION</b>	<b>ANY ANOMALY-WARNING</b>	<b>ANY FAULT</b>	<b>ANY LOCK</b>	<b>ANY COMM LOST</b>
<b>PRESENT</b>					
<b>COMM LOST</b>					

<b>PM STATUS</b>	<b>NORMAL OPERATION</b>	<b>ANOMALY-WARNING</b>	<b>FAULT</b>	<b>LOCK</b>	<b>COMM LOST</b>
<b>STAND-BY</b>					
<b>PRECHARGE</b>					
<b>STARTING - CALIBRATION</b>					
<b>WAIT BATTERY RECHARGE</b>					
<b>LOAD ON INVERTER</b>					
<b>FROM BATTERY</b>					
<b>LOAD ON BYPASS</b>					
<b>EFFICIENCY CONTROL</b>					
<b>LOCKED</b>					
<b>COMM LOST</b>					

<b>BM STATUS</b>	<b>NORMAL OPERATION</b>	<b>ANOMALY-WARNING</b>	<b>FAULT</b>	<b>LOCK</b>	<b>COMM LOST</b>
<b>STAND-BY</b>					
<b>SWITCH ON</b>					
<b>READY</b>					
<b>LOAD ON BYPASS</b>					
<b>LOCKED</b>					
<b>COMM LOST</b>					

<b>SMU STATUS</b>	<b>NORMAL OPERATION</b>	<b>ANOMALY-WARNING</b>	<b>FAULT</b>	<b>COMM LOST</b>
<b>PRESENT</b>				
<b>COMM LOST</b>				

## "UPS SYNOPTIC" TAB

This tab provides a schematic view (synoptic) of the overall operating condition of the selected UPS.

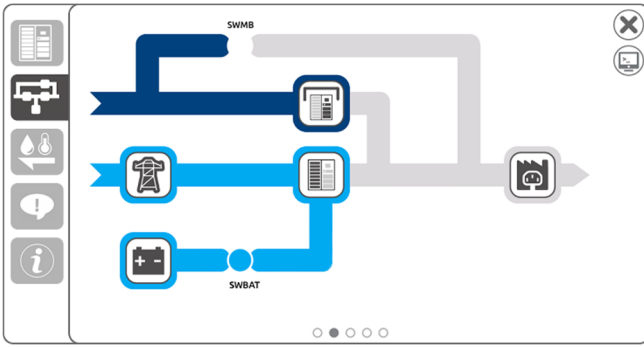

M2X 120 CBC 6

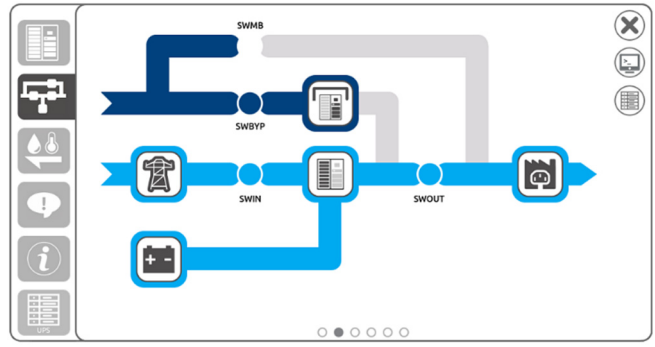

M2X 120 PCS

Synoptic caption:  
 SWIN = Input Switch  
 SWBYP = Bypass Switch  
 SWMB = Switch Manual Bypass  
 SWOUT = Output Switch



it indicates that the switch is open.



it indicates that the the switch is closed.



it indicates that the switch is closed but the UPS is off

Through the Mains Input, Battery, Bypass Input and Output icons on the synoptic, it is possible to access the pages that display the main electrical values of the selected icon.

Voltage		Current	
L1-N	231.6 V	L1	12.6 A
L2-N	232.7 V	L2	12.4 A
L3-N	231.7 V	L3	12.7 A
L1-L2	401.8 V		
L2-L3	402.4 V		
L3-L1	401.3 V		
Frequency	49.97 Hz		

Example of display of the Mains Input page.

Through the upper tabs, it is possible to access the pages of the various electrical values.

## "SENSORS" TAB

This tab shows in real time the various data detected by the sensors installed on the UPS.

**Sensors**

**Temperatures**

Cabinet	29.7 °C		
SMU	33.0 °C	Humidity	38.6 %
External	N.A. °C		

## "ALARM LIST" TAB

This tab shows any alarms present on the UPS.

For further information about this list, please refer to SECTION 1, "Notification/alarm" paragraph.

**Alarm List**

[A56] PM/PMs commLost

## "FIRMWARE/SERIAL NUMBER" TAB

Through this tab it is possible to view the firmware version and serial number of the various elements of the UPS.

using the appropriate icon on the right it is possible to switch from viewing the firmware to viewing the serial number:



switches to the serial number display



switches to the firmware version display

**NOTE:** The example shows a M2X 120 PCS SYSTEM.

**FIRMWARE VERSIONS**

SCU	097-01.17
	<b>1.0.35</b>
PMS	085-01.15
PM4	085-01.15
PM3	085-01.15
PM2	085-01.15
PM1	085-01.15

SWIN SWBYP SWMB  
SWOUT

**SERIAL NUMBERS**

SCU	0002
	<b>1.0.35</b>
PMS	
PM4	
PM3	
PM2	
PM1	LAB2_SN_PM0005

SWIN SWBYP SWMB  
SWOUT

## SECTION 3 – MODULES

From the "UPS status" tab described in the previous chapter, it is possible to access information relating to the elements that compose the UPS. In the representation of the UPS displayed in the centre of the screen, by tapping on the image of one of the present modules (PM, BM, SMU) you will access the configuration and status page of the selected element.

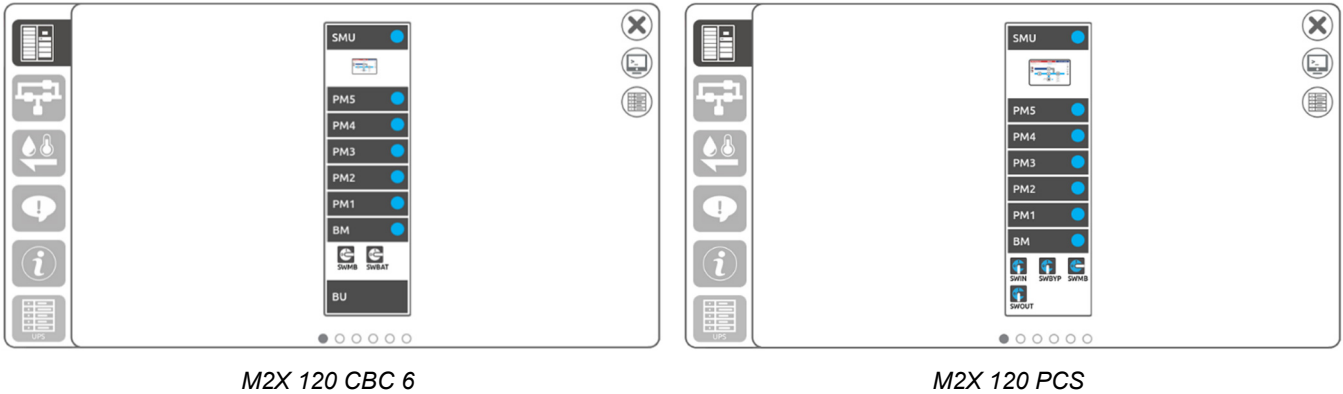

M2X 120 CBC 6

M2X 120 PCS



Depending on the module selected (PM or BM), this is the Command Panel of the corresponding module (*Power User* and *Expert* level only). Allows you to turn the module selected On or Off. For operation, follow the same instructions given in the SECTION 1, "Command Panel" paragraph.

### POWER MODULE (PM) PAGE

#### "PM STATUS" TAB

This tab provides a schematic view (synoptic) of the overall operating condition of the selected PM.

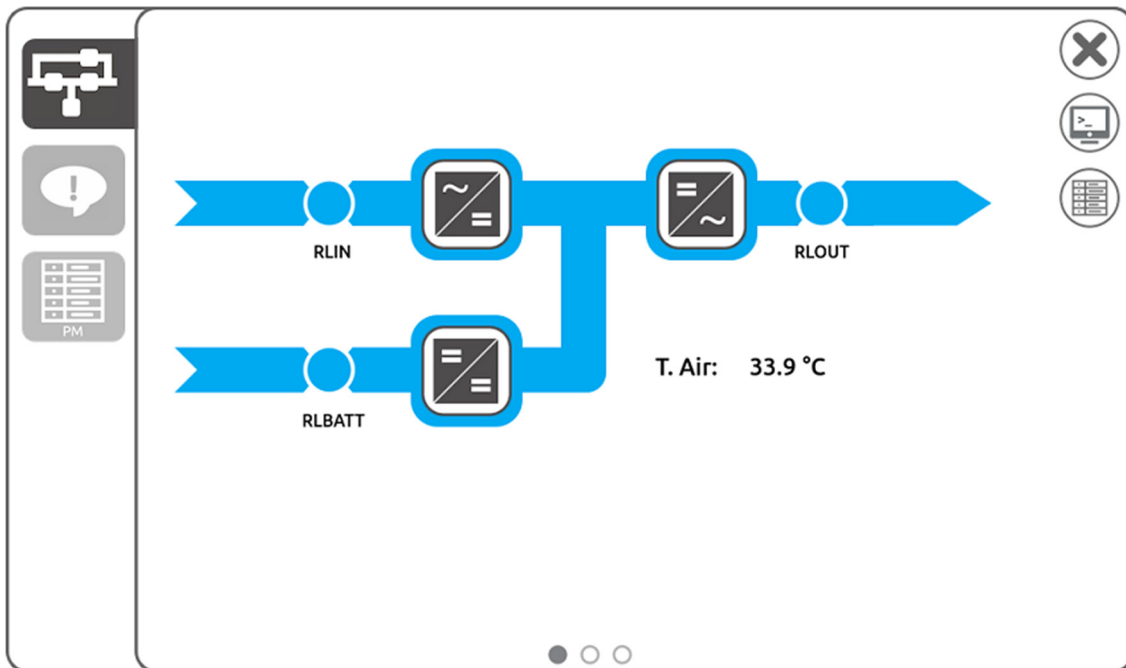

Synoptic caption:  $RLIN$  = Input relay;  $RLOUT$  = Output relay;  $RLBATT$  = Battery relay.



it indicates that the corresponding relay is closed.



it indicates that the corresponding relay is open.

**“ALARM LIST AND INFO” TAB**



This tab shows any alarms present on the Power Module.  
Furthermore, here are shown the main information of the PM (P/N, S/N, FW, Type).

For further information about the alarms please refer to SECTION 1, “Notification/alarm” paragraph.

**BYPASS MODULE (BM) PAGE**

**“BM ELECTRICAL VALUES” TAB**

Through this tab it is possible to view the main electrical values of the Bypass Module.

The screenshot displays the 'Bypass Input' section of the BM Electrical Values tab. It features a sidebar with a list icon and an alarm icon. The main content area shows the following data:

Voltage	
L1-N	243.9 V
L2-N	243.9 V
L3-N	244.1 V
L1-L2	422.3 V
L2-L3	422.8 V
L3-L1	422.3 V

Frequency	49.96 Hz
-----------	----------

Navigation icons for back, close, and home are visible in the top right corner, and a page indicator is at the bottom center.

**“ALARM LIST” TAB**



This tab shows any alarms present on the Bypass Module.

For further information about the alarms please refer to SECTION 1, “Notification/alarm” paragraph.

## SYSTEM MONITORING UNIT (SMU) PAGE

### “EXTERNAL I/O” TAB

The first tab shows an image of the status of the SMU, specifically the status of the I/O communication ports for remote monitoring. The contact ports used are highlighted. Furthermore, each port contains a description of its status. For further information regarding the SMU, refer to the “SMU (System Monitoring Unit)” paragraph in the first part of the manual.

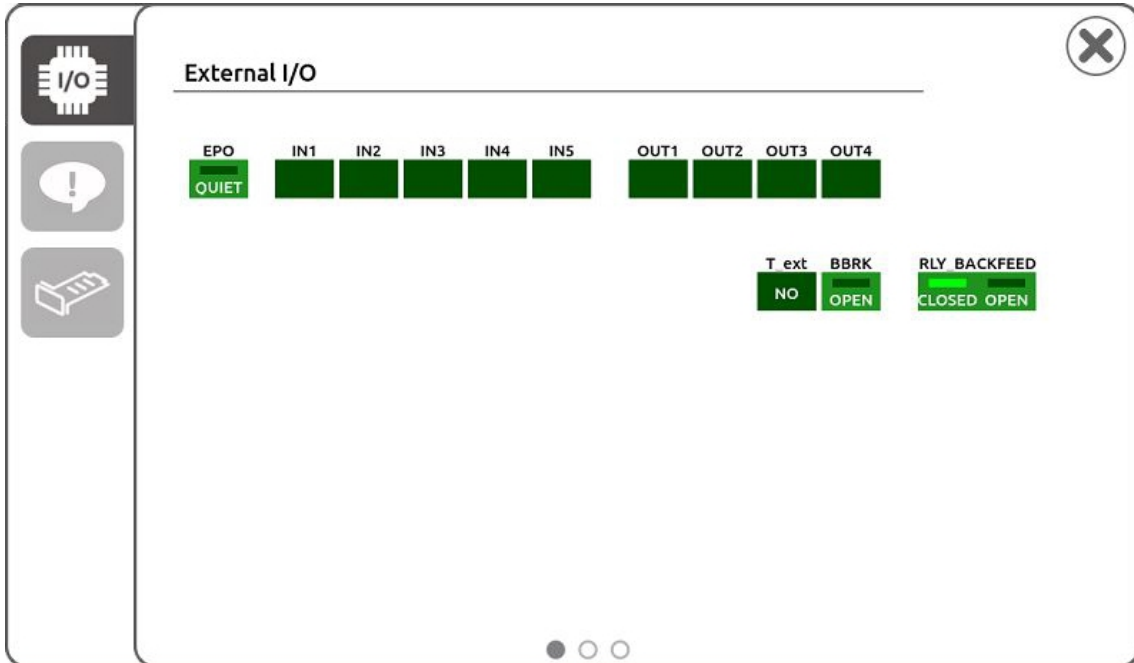

### “SENSORS” TAB



This tab shows in real time the various data detected by the sensors installed on the SMU. Since this is a copy of the same tab already displayed in the UPS section, for further information please refer to the SECTION 2 - UPS, “Sensors” tab paragraph.

### “ALARM LIST” TAB

This tab shows any alarms present on the System Monitoring Unit. For further information about the alarms please refer to SECTION 1, “Notification/alarm” paragraph.

Furthermore, here are shown the main information (P/N, S/N, FW, Type) of the two internal monitoring boards present on the SMU.

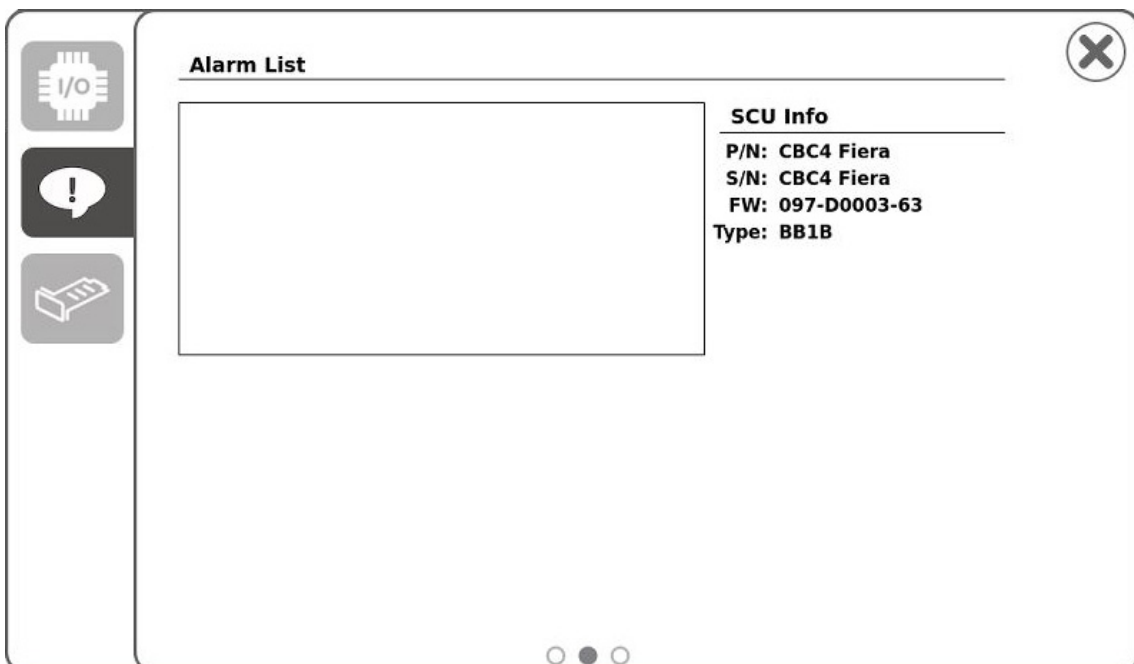

# OPERATIVE PROCEDURES



**Before any attempt to put the system online it is mandatory to check the power supply and connections (PHASE, NEUTRAL, BATTERY). Refer to dedicated Installation manual.**

## SYSTEM ON COMMAND





Operations to be performed in order to Switch On the M2X.

The M2X can be switched to “Normal Operation” in two ways:

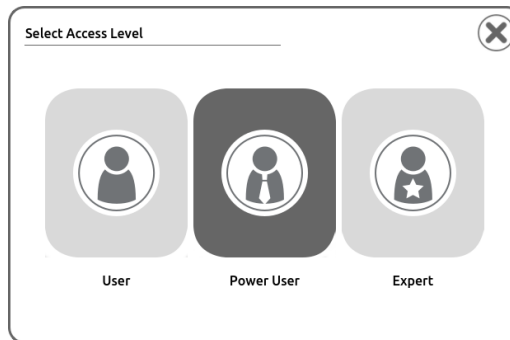
### A. SYSTEM ON: DIRECT COMMAND

- Switch on the Mains and Bypass Input lines.
- Close the internal SWOUT (if present).
- The System will activate and turn in “STAND-BY WITH CB OFF”.
- Press  to select the proper access level and perform the start-up procedure (refer to user manual for further details).



- Verify the Mains  and Bypass  input voltages on the “System Status” page.
- Verify that no anomalies are present on the System status page .
- Verify that all the configured PMs are ready (the red led “ALARM” blinks slowly).
- Verify that Bypass Module has a steady green led on DC OK.
- From the “Commands” Panel page , slide “System OFF/ON” command from “O” to “I” to start the System. Then, confirm “ON command” in the window that appears.

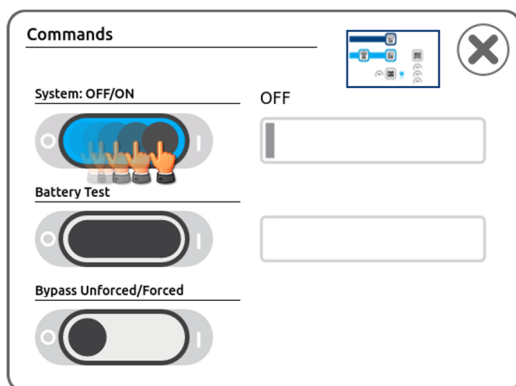

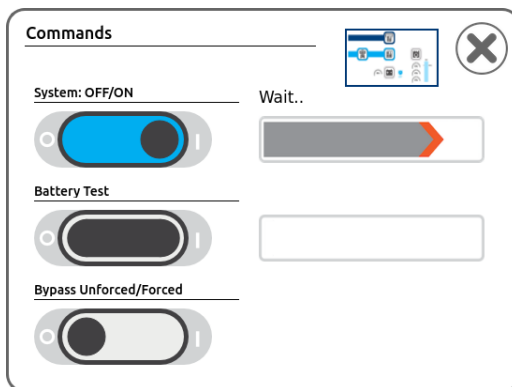

- This command will automatically Start Up the System, showing the progress on the status bar as per the following picture:



During the start up the unit will:

1. Precharge the PMs.
2. Synchronize PMs Inverters.
3. Transfer the load to the Static Bypass Line.
4. Transfer the load on the Inverter Output.

The “Awaiting Start Up” process will take approximately one minute.

- Verify that no anomalies are present on the “System Status” page (except, in case, alarms related to battery status).
- Verify that the measures of inverter voltages  are correct and the System status is “ON LINE”.
- Connect the batteries to the System.
- Check the batteries status  and verify the measures.
- From the “Commands” Panel page  slide the “Battery Test” from “O” to “I” to execute the test. Then, confirm "Battery Test command" in the window that appears.

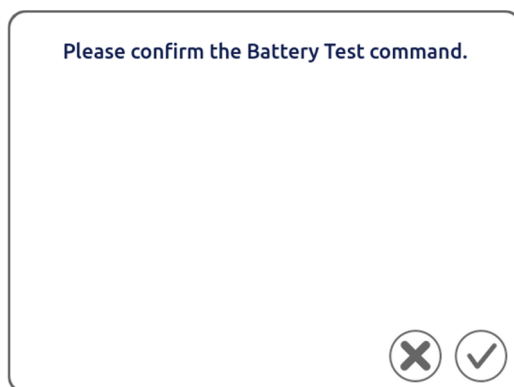
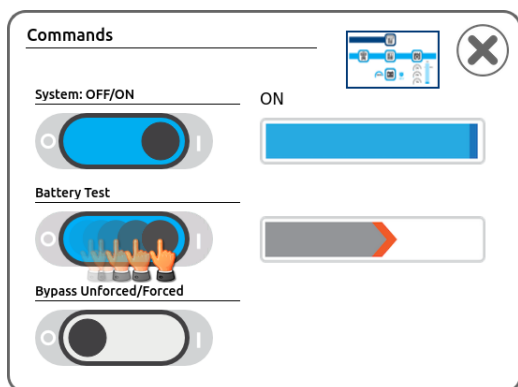

**Note:** the battery test is activated only when the System is ON, the SWOUT is closed and the battery charge level is  $\geq 90\%$ .

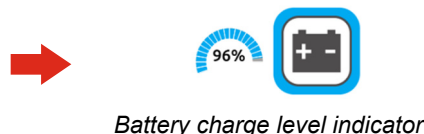





Otherwise, the test will not be executed immediately, however the command remains active and the battery test will start as soon as these conditions are met.

- Verify that the Alarm “Batteries Not Present” is not present.
- From this point the System is in normal operation.

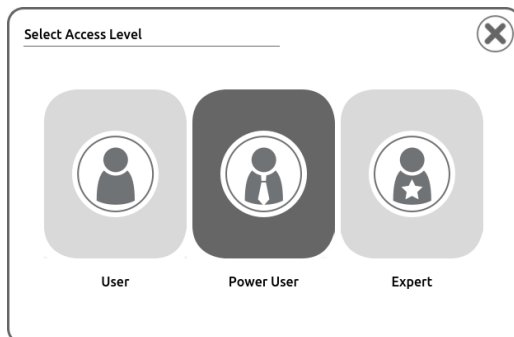
## B. SYSTEM ON: VIA STATIC BYPASS

- Switch on the Mains and Bypass Input lines.
- Close the internal SWOUT (if present).
- The System will activate and turn in “STAND-BY WITH CB CB OFF”.
- Press  to select the proper access level and perform the startup procedure (refer to user manual for further details).



- Verify the Mains  and Bypass  input voltages on the “System Status” page.
- Verify that no anomalies are present on the System status page.
- Verify that all the configured PMs are ready (the red led “ALARM” blinks slowly).
- Verify that Bypass Module has a steady green led on DC OK.
- From the “Commands” panel page , slide “Bypass Unforced/Forced” from “O” to “I” to start the System to static bypass. Then, confirm “Bypass Forced command” in the window that appears (the load will not be supplied yet).

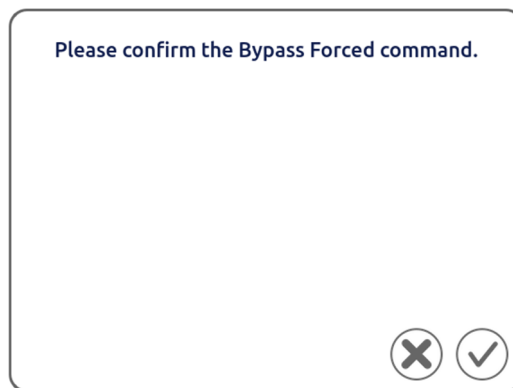
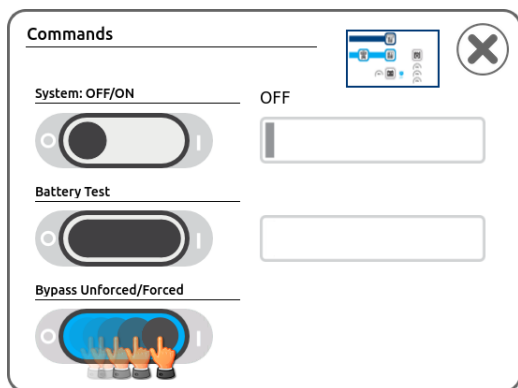

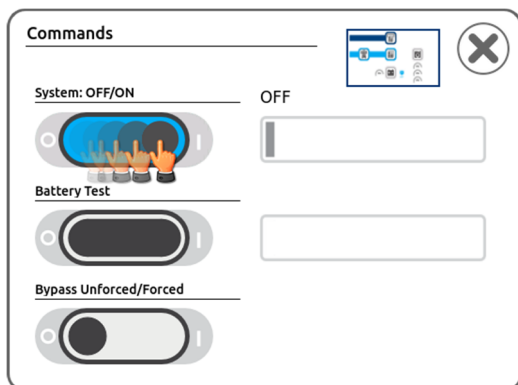

- From the “Commands” Panel page , slide “System OFF/ON” command from “O” to “I” to start the System. Then, confirm “ON command” in the window that appears.

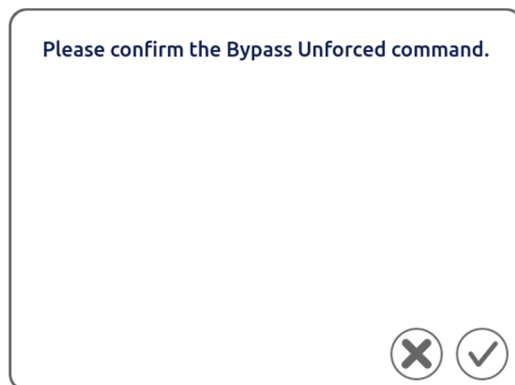
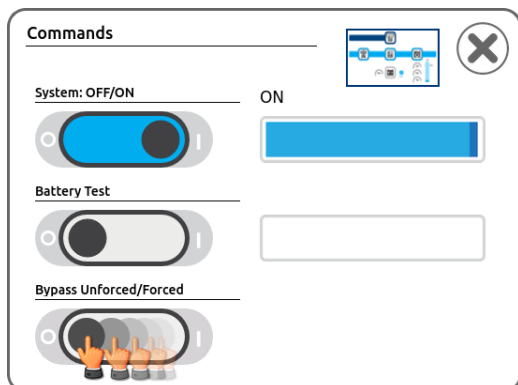

- The power to the load will be supplied via the bypass line. The PMs will be available but not working.
- Verify the output Voltages  on the “System Status” page.
- Deactivate the “Bypass Unforced/Forced” command. Then, confirm “Bypass Unforced command” in the window that appears.



- The inverter will synchronize all of the PMs ready to start.
- In just few seconds the System will transfer the load from the bypass to the inverter output
- Verify that no anomalies are present on the System status page (except, in case, alarms related to battery status).

- Verify that the output  Voltages and the operational status are correct on the “System Status” page.
- Connect the batteries to the System.
- Check the batteries status  and verify the measures.

- From the “Commands” Panel page  slide the “Battery Test” from “O” to “I” to execute the test. Then, confirm “Battery Test command” in the window that appears.

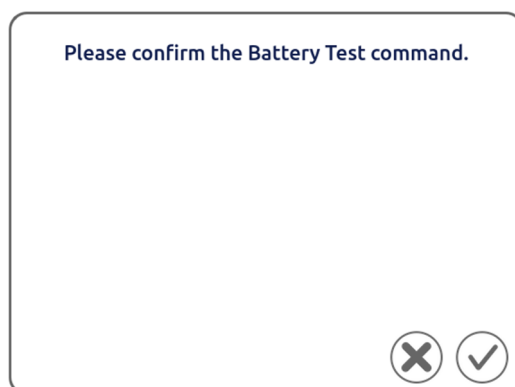
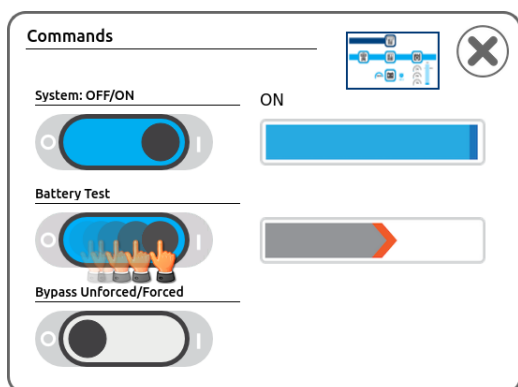

**Note:** the battery test is activated only when the System is ON, the SWOUT is closed and the battery charge level is  $\geq 90\%$ .



Battery charge level indicator

Otherwise, the test will not be executed immediately, however the command remains active and the battery test will start as soon as these conditions are met.

- Verify that the Alarm “Batteries Not Present” is not present anymore.
- From this point the System is in normal operation.

## SWITCHING THE SYSTEM TO MANUAL BYPASS



**ATTENTION:** The SWMB disconnection switch installed on the Modular UPS Cabinet is not a maintenance bypass switch, therefore, there is dangerous voltage within the Cabinet, even if this disconnection switch is closed.



**CAUTION:** Contact a service center should any malfunctions be detected. Maintenance can be carried out only by skilled staff authorized by the manufacturer.

**CAUTION:** dangerous voltages can be present inside the device, even if the input, bypass, output and battery switches are open.



The removal of any enclosure panels from the Modular UPS Cabinet by non-skilled personnel is dangerous and may cause damage to the operator, to the equipment and to the loads connected to it.

Operation to be performed in order to switch the UPS to “Manual Bypass” (in system with only one cabinet).

**Note:** if the bypass line is not present, the manual bypass operation may cut off power to the load. With the SWMB switch closed the bypass input line supplies the load directly. During this mode of operation, any disturbances or blackouts on the power supply line will directly affect the connected equipment.

**Note:** in case of an installation with external SWMB switch, verify first the proper connection of the relative Auxiliary Contact.

The switching of the System to manual bypass can be done with the following procedure:

- Verify that the bypass voltages  are correct on the “System Status” page.
- Verify that the inverters are synchronized to the bypass line (no presence of the message “Bypass not available”).
- Verify that the BM has no anomalies on the “System Status” page.
- From the “Commands” panel page , slide “Bypass Unforced/Forced” from “O” to “I” to start the System to static bypass. Then, confirm "Bypass Forced command" in the window that appears (the load will not be supplied yet).

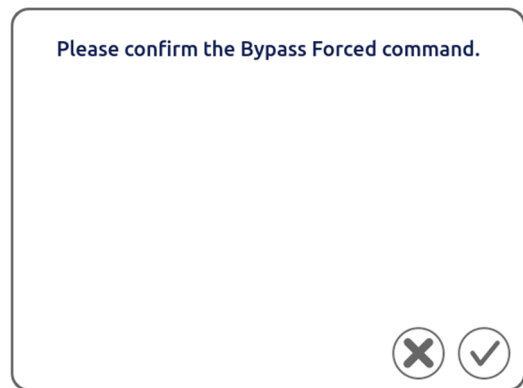
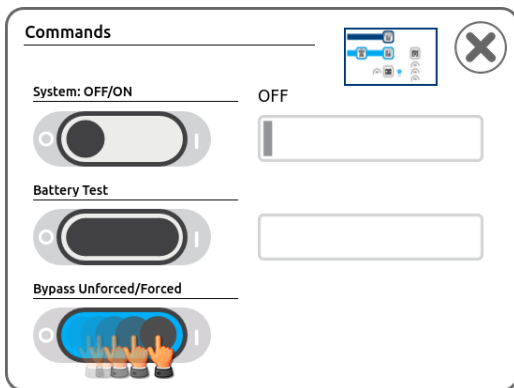

- Close the SWMB switch.
- If needed, in the same page, switch OFF the System and deactivate the “Bypass Unforced/Forced” (confirm the commands in the windows that appears).

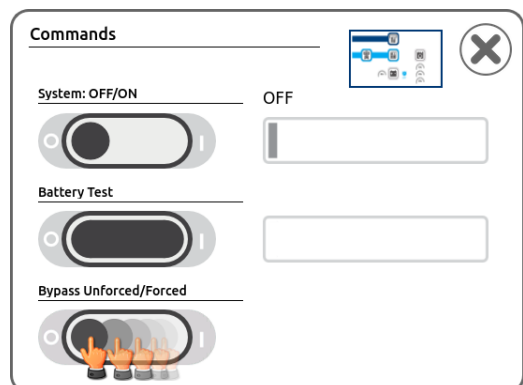
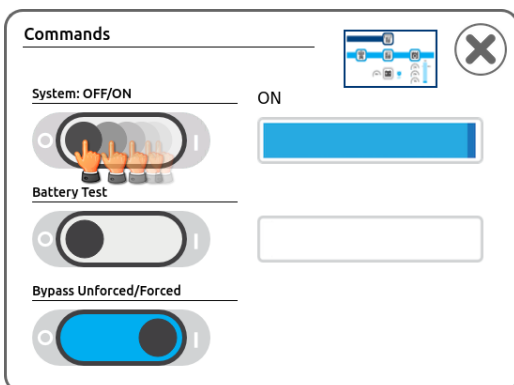

# SWITCHING THE SYSTEM FROM MANUAL BYPASS TO NORMAL OPERATION

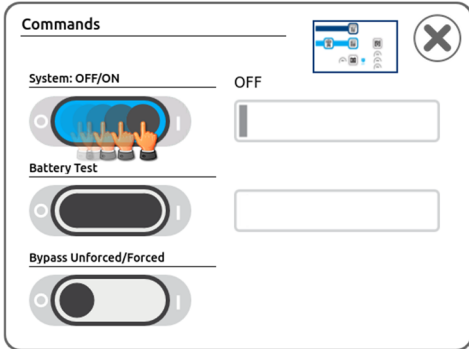

Operation to be performed in order to switch the UPS from “Manual Bypass” to normal operation:

- From the “Commands” Panel page , slide “System OFF/ON” command from “O” to “I” to start the System. Then, confirm “ON command” in the window that appears.

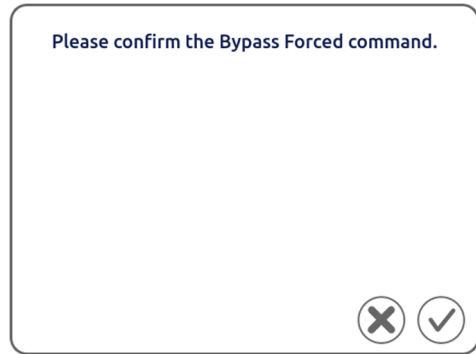
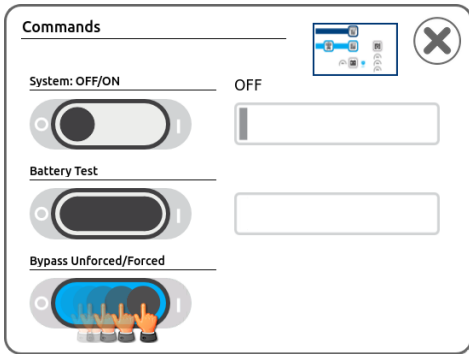

- From the “Commands” panel page , slide “Bypass Unforced/Forced” from “O” to “I” to start the System to static bypass. Then, confirm “Bypass Forced command” in the window that appears (the load will not be supplied yet).



- Open the SWMB switch.
- Verify the output Voltages  on the “System Status” page.
- The power to the load will be supplied via the bypass line. The PMs will be available but not working.
- From the “Commands” Panel page , deactivate the “Bypass Unforced/Forced”. Then, confirm “Bypass Unforced command” in the window that appears.

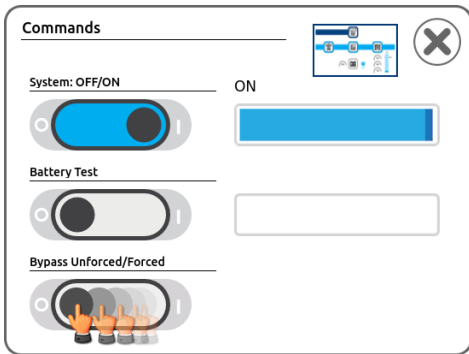

- The inverter will synchronize all of the PMs ready to start.
- In just few seconds the System will transfer the load from the bypass to the inverter output.
- Verify that no anomalies are present on the “System Status” page.
- Verify that the output voltages  and the operational status are correct on the “System Status” page.

# STATUS / ALARM CODES

Using a sophisticated self-diagnosis system, UPS and PM can check and indicate on the display their status and any errors and/or faults that may have occurred during their operation. When a problem occurs, the UPS and/or PM signal the event by showing the code and corresponding type of alarm on the display.

**NOTE:** UPS and PM have dedicated codes. Below will be listed first all the status/alarm codes of the UPSs, followed by all the codes of the PMs.

In case of status/alarm, depending on where the signal appears (UPS or PM), refer to the correct section and table.

## UPS

### STATUSES

These codes indicate the current UPS status.

CODE	DESCRIPTION
S06	Stand-by mode with CB off
S07	Lock stand-by and CB off
S10	Precharge
S11	Precharge from battery
S20	Power off active
S21	Stand-by with CB on
S30	Wait recharge batteries
S31	Calibration
S32	Starting
S40	ON LINE mode
S41	ON LINE / Saving mode
S42	Economy mode
S43	Economy plus mode
S44	Active economy mode
S45	Frequency converter mode
S46	Frequency converter / Saving mode
S47	Ready for emergency
S50	Battery Working
S51	Battery Working forced
S52	Battery low
S60	Temporary bypass
S61	On bypass due to inverter lock
S62	Load forced on bypass
S63	Remote bypass command
S64	Manual bypass active
S65	On bypass due to battery ended
S70	Temporary inverter
S71	On inverter due to bypass lock
S72	Load forced on inverter
S80	Power circulation
S81	Power circulation on battery
S90	Load off
S91	Emergency power off
S92	Disconnected from the load

*UPS status list*

## COMMANDS

These codes indicate that a command has been activated.

CODE	DESCRIPTION
C01	Remote off command
C02	Remote bypass command
C03	Remote on command
C04	Battery test active
C05	Manual bypass command
C06	Emergency off command
C07	Remote battery charger off command
C08	Bypass command active

*UPS command list*

## WARNING

Messages that refer to a specific configuration or operation of the UPS.

CODE	DESCRIPTION
W01	Battery low warning
W02	Shutdown active
W03	Shutdown imminent
W04	Bypass disabled
W05	Synchronisation disabled
W07	Service UPS
W08	Service Battery
W09	BMS status - Warning
W10	BMS cmd - Stop charge
W11	BMS cmd - Stop discharge
W13	Sys. humidity sensor fault
W14	High humidity
W15	Very high umidity
W16	ComRT1 bus degraded
W17	ComRT2 bus degraded
W19	Inconsistent out. powered
W20	Inconsistent batt. working
W21	Inconsistent bypass status
W23	Different MCU firmware ver
W24	PM/PMs warning

*UPS warning list*

## ANOMALIES

Minor problems that do not stop the operation of the UPS, but affect its performance or inhibit the use of some of its functions.

CODE	DESCRIPTION
A01	Configuration data corrupted
A02	Display communication lost
A03	Inverter asynchronous
A04	External synchronism out of range
A05	Mains overvoltage L1
A06	Mains overvoltage L2
A07	Mains overvoltage L3
A08	Mains undervoltage L1
A09	Mains undervoltage L2
A10	Mains undervoltage L3
A11	Mains frequency abnormal
A12	Input switch open
A13	Bypass voltage abnormal L1
A14	Bypass voltage abnormal L2
A15	Bypass voltage abnormal L3
A16	Bypass frequency abnormal
A17	Bypass switch open
A18	Bypass voltage out of range
A22	Load > user threshold L1
A23	Load > user threshold L2
A24	Load > user threshold L3
A25	Output switch open
A26	Battery not present B+
A27	Battery not present B-
A29	System temperature sensor fault
A30	System undertemperature
A31	System overtemperature
A32	Cabinet temperature sensor fault
A33	Cabinet undertemperature
A34	Cabinet overtemperature
A35	Air temperature sensor fault
A36	Air overtemperature
A37	External temperature sensor fault
A38	External sensor overtemperature
A39	Replace battery B+
A40	Replace battery B-
A41	SMU switch ON open
A42	Battery switch open
A43	Alarm from input contact
A44	Main voltage out of range
A45	Load > CSS limit
A46	Deep discharge protection
A47	Different firmware version
A48	PM/PMs anomaly
A49	Date and time not set
A50	Calibration data error A
A51	Calibration data error B
A52	BM switch ON open
A53	BMS status - Anomaly
A54	BMS - Communication lost
A55	ENM - Communication lost
A56	PM/PMs communication lost
A57	Low redundancy
A58	Battery unit high current
A59	Battery unit low current
A60	Battery unit anomaly
A61	Battery configuration error
A62	External output switch open
A63	External input switch open
A64	External bypass switch open

*UPS alarm list*

## FAULTS

Faults are problems more critical than “Anomalies” in that, if they persist, they may bring the UPS to a stop.

CODE	DESCRIPTION
F01	Internal communication error
F02	Mains phases reversed
F03	SCU auxiliary power fault
F06	SCU EPO fault
F08	EPO redundancy error
F09	SWOUT redundancy error
F10	SWMB redundancy error
F11	UGS disconnected
F12	Bypass phases reversed
F13	Vneutral-Vground overlimit
F14	Inverter sinewave abnormal L1
F15	Inverter sinewave abnormal L2
F16	Inverter sinewave abnormal L3
F18	Output Vdc balance error
F19	Battery overvoltage B+
F20	Battery overvoltage B-
F21	Battery undervoltage B+
F22	Battery undervoltage B-
F23	Output overload
F24	Bypass not available
F25	Output negative power
F26	SCU link open
F29	SCU communication lost
F32	Lost redundancy
F33	Bypass overtemperature L1
F34	Bypass overtemperature L2
F35	Bypass overtemperature L3
F36	Bypass fan1 fault
F37	Bypass fan2 fault
F38	Bypass fan3 fault
F39	SMU switch_ON redund. err.
F40	17V_CAB redundancy error
F41	SCU code/FW incompatible
F44	PIB1 communication lost
F45	PIB2 communication lost
F46	ComRT1 bus off
F47	ComRT2 bus off
F48	Battery polarity error
F49	Battery unit fault
F50	SLOT LAN communicat. lost
F51	SLOT communication lost
F52	BMS status - Fault
F53	17V_CAB aux. power fault
F54	Memory access error A
F55	Memory access error B
F64	PM/PMs fault/lock

*UPS fault list*

## LOCKS

Locks indicate a breakdown of the UPS or one of its parts. Locks are normally preceded by an alarm signal. In the event of a fault and resultant breakdown of the inverter, the inverter will be switched off and the load will be powered by the bypass line (this procedure is excluded for breakdowns caused by high and persistent overloads and by short circuits).

CODE	DESCRIPTION
L01	Auxiliary power fault
L03	Bypass fuse fault L1
L04	Bypass fuse fault L2
L05	Bypass fuse fault L3
L08	Bypass backfeed L1
L09	Bypass backfeed L2
L10	Bypass backfeed L3
L11	Bypass output fault L1
L12	Bypass output fault L2
L13	Bypass output fault L3
L14	Inverter overvoltage L1
L15	Inverter overvoltage L2
L16	Inverter overvoltage L3
L17	Inverter undervoltage L1
L18	Inverter undervoltage L2
L19	Inverter undervoltage L3
L20	Inverter sinewave abnormal L1
L21	Inverter sinewave abnormal L2
L22	Inverter sinewave abnormal L3
L23	Output overload L1
L24	Output overload L2
L25	Output overload L3
L26	Output short-circuit L1
L27	Output short-circuit L2
L28	Output short-circuit L3
L29	Bypass auxiliary power fault L1
L30	Bypass auxiliary power fault L2
L31	Bypass auxiliary power fault L3
L38	Bypass temperature sensor fault L1
L39	Bypass temperature sensor fault L2
L40	Bypass temperature sensor fault L3
L45	Parallel bus division
L46	Parallel communication fault
L47	PIB address error
L52	Module link open
L53	Board code/FW incompatible
L58	BMS status - Lock
L63	Bypass locked
L64	All Inverters locked

*UPS lock list*

# PM

## STATUSES

These codes indicate the current PM status.

CODE	DESCRIPTION
S06	Stand-by mode with CB off
S07	Lock stand-by and CB off
S10	Precharge
S11	Precharge from battery
S20	Power off active
S21	Stand-by with CB on
S30	Wait recharge batteries
S31	Calibration
S32	Starting
S40	ON LINE mode
S41	ON LINE / Saving mode
S42	Economy mode
S43	Economy plus mode
S44	Active economy mode
S45	Frequency converter mode
S46	Frequency converter / Saving mode
S47	Ready for emergency
S50	Battery Working
S51	Battery Working forced
S52	Battery low
S60	Temporary bypass
S61	On bypass due to inverter lock
S62	Load forced on bypass
S63	Remote bypass command
S64	Manual bypass active
S65	On bypass due to battery ended
S70	Temporary inverter
S71	On inverter due to bypass lock
S72	Load forced on inverter
S80	Power circulation
S81	Power circulation on battery
S90	Load off
S91	Emergency power off
S92	Disconnected from the load

*PM status list*

## COMMANDS

These codes indicate that a command has been activated.

CODE	DESCRIPTION
C04	Battery test active

*PM command list*

## WARNING

Messages that refer to a specific configuration or operation of the UPS.

CODE	DESCRIPTION
W01	Battery low warning
W02	Shutdown active
W03	Shutdown imminent
W07	Service UPS
W16	ComRT1 bus degraded
W17	ComRT2 bus degraded
W19	Phases load very unbalanced

*PM warning list*

## ANOMALIES

Minor problems that do not stop the operation of the PM, but affect its performance or inhibit the use of some of its functions.

CODE	DESCRIPTION
A01	Configuration data corrupted
A03	Inverter asynchronous
A04	External synchronism out of range
A05	Mains overvoltage L1
A06	Mains overvoltage L2
A07	Mains overvoltage L3
A08	Mains undervoltage L1
A09	Mains undervoltage L2
A10	Mains undervoltage L3
A11	Mains frequency abnormal
A13	Bypass voltage abnormal L1
A14	Bypass voltage abnormal L2
A15	Bypass voltage abnormal L3
A16	Bypass frequency abnormal
A18	Bypass voltage out of range
A26	Battery not present B+
A27	Battery not present B-
A29	System temperature sensor fault
A30	System undertemperature
A31	System overtemperature
A32	Buck-boost undertemperature
A33	Inverter undertemperature
A35	Air temperature sensor fault
A36	Air overtemperature
A37	Aux temperature sensor fault
A38	Aux overtemperature
A39	Replace battery B+
A40	Replace battery B-
A41	Switch ON open
A44	Mains voltage out of range
A47	Different firmware version
A49	Date and time not set
A50	Calibration data error A
A51	Calibration data error B

*PM alarm list*

## FAULTS

Faults are problems more critical than “Anomalies” in that, if they persist, they may bring the PM to a stop.

CODE	DESCRIPTION
F01	Internal communication error
F02	Mains phases reversed
F03	Input fuse/contact fault L1
F04	Input fuse/contact fault L2
F05	Input fuse/contact fault L3
F06	Input contact short cct L1
F07	Input contact short cct L2
F08	Input contact short cct L3
F09	Precharge DC bus error B+
F10	Precharge DC bus error B-
F11	Booster fault
F12	Bypass phases reversed
F13	Boost voltage error
F14	Inverter sinewave abnormal L1
F15	Inverter sinewave abnormal L2
F16	Inverter sinewave abnormal L3
F17	Inverter error
F18	Output Vdc balance error
F19	Battery overvoltage B+
F20	Battery overvoltage B-
F21	Battery undervoltage B+
F22	Battery undervoltage B-
F23	Output overload
F24	Bypass not available
F25	Output negative power
F26	Output contact short cct L1
F27	Output contact short cct L2
F28	Output contact short cct L3
F29	Output fuse/contact fault L1
F30	Output fuse/contact fault L2
F31	Output fuse/contact fault L3
F32	Battery charger fault
F33	Battery measures error
F34	Power module overtemperature
F36	Fan fault F1
F37	Fan fault F2
F38	Fan fault F3
F39	Vdc bus measures error
F40	Battery fuse B+
F41	Battery fuse B-
F44	PIB1 communication lost
F45	PIB2 communication lost
F46	ComRT1 bus off
F47	ComRT2 bus off
F48	Battery polarity error
F49	Battery contact cmd fault
F51	Battery contact short cct
F54	Memory access error A
F55	Memory access error B
F56	Calibration error PFC
F57	Calibration error INV
F58	Calibration error BAT
F60	SCU Communication lost

*PM fault list*

## LOCKS

Locks indicate a breakdown of the PM or one of its parts. Locks are normally preceded by an alarm signal.

CODE	DESCRIPTION
L01	Auxiliary power fault
L02	Boards link fault
L03	Input fuse/contact fault L1
L04	Input fuse/contact fault L2
L05	Input fuse/contact fault L3
L06	Boost overvoltage B+
L07	Boost overvoltage B-
L08	Boost undervoltage B+
L09	Boost undervoltage B-
L14	Inverter overvoltage L1
L15	Inverter overvoltage L2
L16	Inverter overvoltage L3
L17	Inverter undervoltage L1
L18	Inverter undervoltage L2
L19	Inverter undervoltage L3
L20	Inverter sinewave abnormal L1
L21	Inverter sinewave abnormal L2
L22	Inverter sinewave abnormal L3
L23	Output overload L1
L24	Output overload L2
L25	Output overload L3
L26	Output short-circuit L1
L27	Output short-circuit L2
L28	Output short-circuit L3
L29	Output fuse/contact fault L1
L30	Output fuse/contact fault L2
L31	Output fuse/contact fault L3
L34	Buck-boost overtemperature
L35	Inverter overtemperature
L38	Boost temperature sensor fault
L39	Inverter temperature sensor fault
L42	Battery fuse fault
L43	Battery contact short cct
L45	Parallel bus division
L46	Parallel communication fault
L47	PIB address error
L49	Output capacitor overtemperature
L50	Input capacitor overtemperature
L51	Battery charger short-circuit
L52	PM link open
L53	Board code/FW incompatible
L54	Input board code unknown
L64	Self-exclusion activated

*PM lock list*

# TECHNICAL DATA TABLE

M2X - from 15 to 120kW		
<b>INPUT</b>		
Voltage [V <sub>LL</sub> ]	380-415 AC 3 phase plus neutral	
Accepted tolerance for input voltage [%]	- 20 + 20 @ 100% load -40 + 20 @ 50% load	
Frequency tolerance [Hz]	40-72	
Power factor	≥ 0,99	
THDI [%]	≤ 3%	
Power Walk-in	Programmable from 1 to 120 sec. in steps of 1 sec.	
<b>BYPASS</b>		
Nominal power [kW]	120	
Nominal voltage [V <sub>LL</sub> ]	380-415V AC 3 phase plus neutral	
Voltage tolerance [%]	from -22 to +15 (adjustable in step of 4V)	
Nominal frequency [Hz]	50 / 60	
Overload	103%±≤110% 60min > 111%±≤125% 10 min. > 125%±≤150% 1 min. > 150% 1 sec.	
<b>BATTERIES</b>		
Battery arrangement	Separate or common batteries at UPS level	
Number of poles	3 wires (+/N/-)	
Battery block per string – VRLA	20 (other configurations available upon request)	
Standard maximum recharging current [A]	12 A per power module (PM15), 20 A per power module (PM30)	
Compatible with	VRLA, Ni - Cd, Lithium & Supercaps	
<b>OUTPUT</b>		
Nominal voltage [V <sub>LL</sub> ]	380-415V AC 3-phase plus neutral	
Nominal frequency [Hz]	50 or 60	
Voltage stability [%]	± 1	
Dynamic stability	IEC EN 62040-3 Performance Class 1	
Overload	>103%±≤125% 10 min. >125%±≤150% 1 min. >150% 0.5 sec	
<b>GENERAL SPECIFICATIONS</b>		
UPS type	M2X 120 CBC 6	M2X 120 PCS
Power Module nominal power [kW]	15 or 30 (M2X 15 PM or M2X 15-30 PM BLUE)	15 or 30 (M2X 15 PM or M2X 15-30 PM BLUE)
Nominal power [kW]	120 <sup>1</sup>	
Output power factor	1	
Can be installed in parallel	Up to 4	
Cabinet configuration	Up to 5 x PM15 or PM30	
Cabinet IP Class	IP20 protection for fingers (with open or closed cabinet doors)	
Colour	RAL 9005	
Operating ambient temperature	0 – 40 °C	
Standards	Safety: IEC EN 62040-1 EMC: IEC EN 62040-2 Category C3	
Mobile Cabinet	Castors (UPS are sent without PM <sup>2</sup> )	
<b>DIMENSIONS AND WEIGHT<sup>3</sup></b>		
Dimensions (WxDxH) [mm]	600 x 985 x 1995	600 x 940 x 1590
Weight (without PM) [kg]	275	196

<sup>1</sup> The power shown is the maximum values according with cabinet type; the real value is associated to the number of PM installed.

<sup>2</sup> PM = Power Module (referring to the 15 or 30 kW [PM 15, 15 BLUE or 30 BLUE] module)

<sup>3</sup> Without packaging





[www.riello-ups.com](http://www.riello-ups.com)

RPS SpA – *Riello Power Solutions*  
Viale Europa, 7  
37045 Legnago (VR)  
Italy

0MNM2XK15RUENUA