

High Performance Mains Filter A11x71

Features

- Mains Filter for single and three phase systems
- Insertion transmission loss 100 dB @ 150 kHz
- Rod cores allow asymmetrical load
- Self-healing effect of foil capacitors

For a clean mains supply into a shielded room, high performance filters are indispensable. Usually, these filters are directly mounted on the shielding wall. It is recommended to route filtered lines into the shielded room through the wall with an optional flexible metal conduit.

Description

The A11x71 high performance filter is a superior mains filter housed in a three compartment casing that achieves 100 dB insertion transmission loss at 150 kHz.

The circuit is designed as a symmetrical π -circuit with high quality rod cores providing inductance. These cores do not saturate due to their large air gap and they are insensitive to asymmetrical load.

Foil capacitors ensure a long operating life by their self healing feature even after voltage transients.

A seamless fixing of the filter casing to the shielded room is very important to ensure correct operation. The filter is housed in a casing that has a base flange which provides stable mounting and excellent earthing when bolted to the shielded room via the mounting bolts.

This series is offered as a two line filter (phase and neutral) or as a four line filter (three phases and neutral). The neutral line is always attenuated and all conductors are decoupled from each other. This allows the conductors to operate independently without attenuation loss.

Input and output terminals are accessible under high frequency shielding caps. EMP protection is available on request.



Technical Data

Mains voltage	250/440 V _{AC} ; 50/60 Hz; 600 V _{DC}
Current rating	relative to 50 Hz and 40 °C ambient temperature
Current rating	1,4 I _N for 15 minutes
Ambient temperature	-40 °C to + 40 °C
Test voltage	1200 V _{DC} for 2 s (line / line; line / earth)

Models and Ordering Data

Order No.	Type	Number of lines	Rated Current	Voltage drop	Leakage current per line	Weight
012 00061	71/2x 6 A	2	6 A	1.3 V _{DC} , 2 V _{AC}	0.3 A	7 kg
012 00070	71/4x 6 A	4	6 A	1.3 V _{DC} , 2 V _{AC}	0.3 A	14 kg
012 00062	71/2x 10 A	2	10 A	0.8 V _{DC} , 2 V _{AC}	0.5 A	7 kg
012 00071	71/4x 10 A	4	10 A	0.8 V _{DC} , 2 V _{AC}	0.5 A	14 kg
012 00063	71/2x 16 A	2	16 A	0.9 V _{DC} , 2 V _{AC}	0.6 A	8 kg
012 00072	71/4x 16 A	4	16 A	0.9 V _{DC} , 2 V _{AC}	0.6 A	16 kg
012 00064	71/2x 25 A	2	25 A	0.5 V _{DC} , 2 V _{AC}	0.8 A	9 kg
012 00073	71/4x 25 A	4	25 A	0.5 V _{DC} , 2 V _{AC}	0.8 A	18 kg
012 00065	71/2x 40 A	2	40 A	0.5 V _{DC} , 2 V _{AC}	1.0 A	11 kg
012 00074	71/4x 40 A	4	40 A	0.5 V _{DC} , 2 V _{AC}	1.0 A	22 kg
012 00066	71/2x 63 A	2	63 A	0.5 V _{DC} , 2 V _{AC}	0.8 A	25 kg
012 00075	71/4x 63 A	4	63 A	0.5 V _{DC} , 2 V _{AC}	0.8 A	50 kg
012 00067	71/2x 85 A	2	85 A	0.4 V _{DC} , 2 V _{AC}	1.0 A	26 kg
012 00076	71/4x 85 A	4	85 A	0.4 V _{DC} , 2 V _{AC}	1.0 A	52 kg
012 00068	71/2x125 A	2	125 A	0.4 V _{DC} , 2 V _{AC}	1.2 A	30 kg
012 00077	71/4x125 A	4	125 A	0.4 V _{DC} , 2 V _{AC}	1.2 A	60 kg
012 00069	71/2x200 A	2	200 A	0.4 V _{DC} , 2 V _{AC}	1.4 A	35 kg
012 00078	71/4x200 A	4	200 A	0.4 V _{DC} , 2 V _{AC}	1.4 A	70 kg

TESCH

EMC Division

Circuitry A11x71/4x...

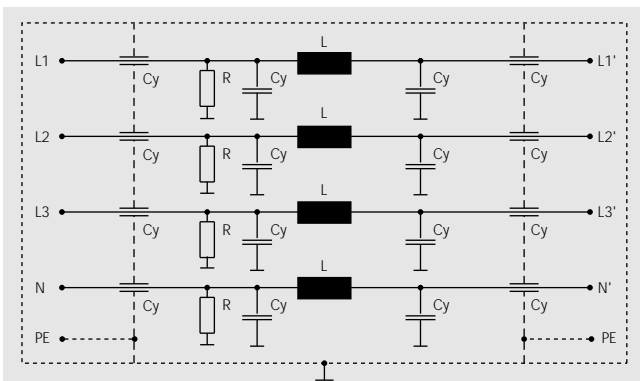

Circuitry A11x71/2x...

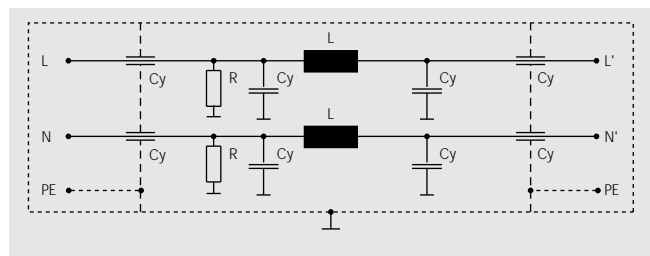

Suppression Characteristics

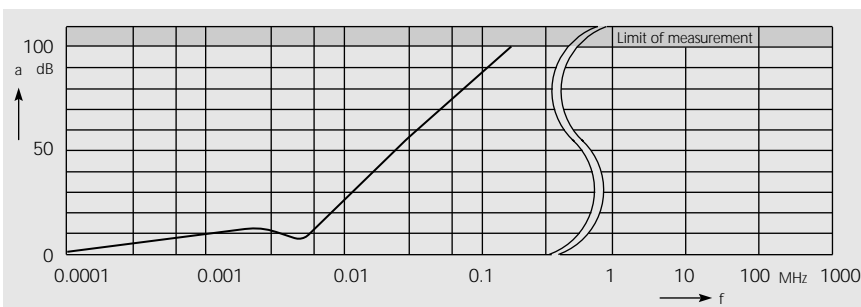

Dimension Drawing

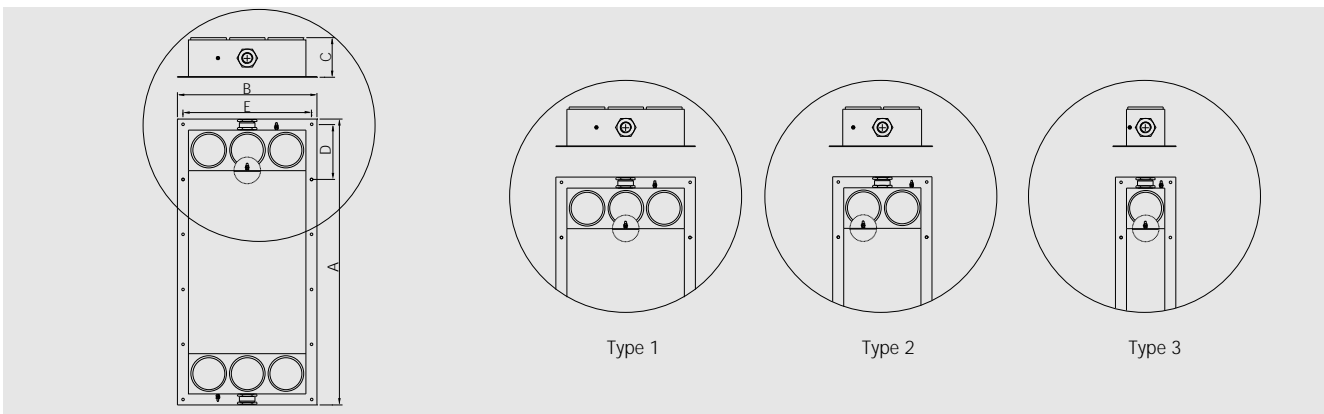

Mechanical Dimensions

Type	Drawing Ref.	Dimensions					Fixing hole diameter	Screened cable gland	cable diameter	terminal thread size
		A	B	C	D	E				
71/2x 6/10 /16 A	3	470	150	102	90	130	Ø 7	Pg 21	Ø 22	M 5
71/4x 6/10 /16 A	2	470	260	102	90	240	Ø 7	Pg 21	Ø 22	M 5
71/2x 25 / 40 A	2	570	260	102	110	240	Ø 7	Pg 21	Ø 22	M 5
71/4x 25 / 40 A	1	570	380	102	110	360	Ø 7	Pg 21	Ø 22	M 5
71/2x 63 / 85 A	3	900	350	150	170	300	Ø 11	Pg 29	Ø 30	M 8
71/4x 63 / 85 A	2	900	550	150	170	500	Ø 11	Pg 29	Ø 30	M 8
71/2x125 / 200 A	3	1200	350	150	230	300	Ø 11	Pg 42	Ø 46	M 12
71/4x125 / 200 A	2	1200	550	150	230	500	Ø 11	Pg 42	Ø 46	M 12

